

HDL Coder™

Reference



MATLAB® & SIMULINK®

R2020a



How to Contact MathWorks



Latest news: www.mathworks.com
Sales and services: www.mathworks.com/sales_and_services
User community: www.mathworks.com/matlabcentral
Technical support: www.mathworks.com/support/contact_us



Phone: 508-647-7000



The MathWorks, Inc.
1 Apple Hill Drive
Natick, MA 01760-2098

HDL Coder™ Reference

© COPYRIGHT 2013–2020 by The MathWorks, Inc.

The software described in this document is furnished under a license agreement. The software may be used or copied only under the terms of the license agreement. No part of this manual may be photocopied or reproduced in any form without prior written consent from The MathWorks, Inc.

FEDERAL ACQUISITION: This provision applies to all acquisitions of the Program and Documentation by, for, or through the federal government of the United States. By accepting delivery of the Program or Documentation, the government hereby agrees that this software or documentation qualifies as commercial computer software or commercial computer software documentation as such terms are used or defined in FAR 12.212, DFARS Part 227.72, and DFARS 252.227-7014. Accordingly, the terms and conditions of this Agreement and only those rights specified in this Agreement, shall pertain to and govern the use, modification, reproduction, release, performance, display, and disclosure of the Program and Documentation by the federal government (or other entity acquiring for or through the federal government) and shall supersede any conflicting contractual terms or conditions. If this License fails to meet the government's needs or is inconsistent in any respect with federal procurement law, the government agrees to return the Program and Documentation, unused, to The MathWorks, Inc.

Trademarks

MATLAB and Simulink are registered trademarks of The MathWorks, Inc. See www.mathworks.com/trademarks for a list of additional trademarks. Other product or brand names may be trademarks or registered trademarks of their respective holders.

Patents

MathWorks products are protected by one or more U.S. patents. Please see www.mathworks.com/patents for more information.

Revision History

March 2013	Online only	New for Version 3.2 (R2013a)
September 2013	Online only	Revised for Version 3.3 (R2013b)
March 2014	Online only	Revised for Version 3.4 (Release 2014a)
October 2014	Online only	Revised for Version 3.5 (Release 2014b)
March 2015	Online only	Revised for Version 3.6 (Release 2015a)
September 2015	Online only	Revised for Version 3.7 (Release 2015b)
October 2015	Online only	Rereleased for Version 3.6.1 (Release 2015aSP1)
March 2016	Online only	Revised for Version 3.8 (Release 2016a)
September 2016	Online only	Revised for Version 3.9 (Release 2016b)
March 2017	Online only	Revised for Version 3.10 (Release 2017a)
September 2017	Online only	Revised for Version 3.11 (Release 2017b)
March 2018	Online only	Revised for Version 3.12 (Release 2018a)
September 2018	Online only	Revised for Version 3.13 (Release 2018b)
March 2019	Online only	Revised for Version 3.14 (Release 2019a)
September 2019	Online only	Revised for Version 3.15 (Release 2019b)
March 2020	Online only	Revised for Version 3.16 (Release 2020a)

1	Apps
2	Functions
3	Blocks
4	Properties
5	Classes for HDL Code Generation from Simulink
6	Functions for HDL Code Generation from MATLAB
7	Classes for HDL Code Generation from MATLAB
8	Shared Classes and Functions for HDL Code Generation from MATLAB and Simulink

Apps

HDL Coder

Generate HDL code from MATLAB code

Description

The **HDL Coder** app generates synthesizable HDL code from MATLAB[®] code that is supported for hardware. You can generate VHDL or Verilog HDL code that you can integrate into existing HDL applications outside of MATLAB.

The workflow-based user interface steps you through the code generation process. Using the app, you can:

- Create a project or open an existing HDL Coder project.
- Specify the MATLAB function and the MATLAB testbench for your project.
- Propose input data types or autodefine data types by specifying the MATLAB testbench file.
- Convert floating-point MATLAB code to fixed-point HDL code.
- Specify the target device and synthesis tool to deploy the generated HDL code on the target hardware.
- Access generated files and view code generation reports.
- Verify the numerical behavior of generated HDL code with HDL test bench, cosimulation, or FPGA-in-the loop.
- Synthesize, and place and route the generated HDL code for the specified hardware with the Generic ASIC/FPGA workflow.
- Integrate your generated HDL IP core with the embedded processor by using IP Core Generation workflow.
- Generate a programming file and download it to the target device with the FPGA Turnkey workflow.

Open the HDL Coder App

- MATLAB Toolstrip: On the **Apps** tab, under **Code Generation**, click the **HDL Coder** app icon.
- MATLAB command prompt: Enter `hdlcoder`.

Examples

- “Basic HDL Code Generation and FPGA Synthesis from MATLAB by Using the Workflow Advisor”

Programmatic Use

`hdlcoder` opens the **HDL Coder** app.

See Also

Apps

Fixed-Point Converter

Functions

codegen

Topics

“Basic HDL Code Generation and FPGA Synthesis from MATLAB by Using the Workflow Advisor”

“Guidelines for Writing MATLAB Code to Generate Efficient HDL Code”

“Create and Set Up Your Project”

Introduced in R2012a

Functions

checkhdl

Check subsystem or model for HDL code generation compatibility

Syntax

```
checkhdl(bdroot)
checkhdl('dut')
checkhdl(gcb)
output = checkhdl('system')
```

Description

`checkhdl` generates an HDL Code Generation Check Report, saves the report to the target folder, and displays the report in a new window. Before generating HDL code, use `checkhdl` to check your subsystems or models.

Note Running this command can activate the **Open at simulation start** setting for blocks such as the Scope block and therefore invoke the block.

The report lists compatibility errors with a link to each block or subsystem that caused a problem. To highlight and display incompatible blocks, click each link in the report while keeping the model open.

The report file name is `system_report.html`. `system` is the name of the subsystem or model passed in to `checkhdl`.

When a model or subsystem passes `checkhdl`, that does not imply code generation will complete. `checkhdl` does not verify all block parameters.

`checkhdl(bdroot)` examines the current model for HDL code generation compatibility.

`checkhdl('dut')` examines the specified DUT model name, model reference name, or subsystem name with full hierarchical path.

`checkhdl(gcb)` examines the currently selected subsystem.

```
output = checkhdl('system')
```

does not generate a report. Instead, it returns a 1xN struct array with one entry for each error, warning, or message. `system` specifies a model or the full block path for a subsystem at any level of the model hierarchy.

`checkhdl` reports three levels of compatibility problems:

- *Errors*: cause the code generation process to terminate. The report must not contain errors to continue with HDL code generation.
- *Warnings*: indicate problems in the generated code, but allow HDL code generation to continue.
- *Messages*: indication that some data types have special treatment. For example, the HDL Coder software automatically converts single-precision floating-point data types to double-precision because VHDL[®] and Verilog[®] do not support single-precision data types.

Examples

Check the subsystem `symmetric_fir` within the model `sfir_fixed` for HDL code generation compatibility and generate a compatibility report.

```
checkhdl('sfir_fixed/symmetric_fir')
```

Check the subsystem `symmetric_fir_err` within the model `sfir_fixed_err` for HDL code generation compatibility, and return information on problems encountered in the struct output.

```
output = checkhdl('sfir_fixed_err/symmetric_fir_err')
### Starting HDL Check.
...
### HDL Check Complete with 4 errors, warnings and messages.
```

The following MATLAB commands display the top-level structure of the struct output, and its first cell.

```
output =
1x4 struct array with fields:
    path
    type
    message
    level

output(1)
ans =
    path: 'sfir_fixed_err/symmetric_fir_err/Product'
    type: 'block'
    message: 'Unhandled mixed double and non-double datatypes at ports of block'
    level: 'Error'
```

See Also

`makehdl`

Topics

“Create Simulink Model for HDL Code Generation”

“Check Your Model for HDL Compatibility”

Introduced in R2006b

hdladvisor

Display HDL Workflow Advisor

Syntax

```
hdladvisor(gcf)
hdladvisor(subsystem)
hdladvisor(model, 'SystemSelector')
```

Description

`hdladvisor(gcf)` starts the HDL Workflow Advisor, passing the currently selected subsystem within the current model as the DUT to be checked.

`hdladvisor(subsystem)` starts the HDL Workflow Advisor, passing in the path to a specified subsystem within the model.

`hdladvisor(model, 'SystemSelector')` opens a System Selector window that lets you select a subsystem to be opened into the HDL Workflow Advisor as the device under test (DUT) to be checked.

Examples

Open the subsystem `symmetric_fir` within the model `sfir_fixed` into the HDL Workflow Advisor.

```
hdladvisor('sfir_fixed/symmetric_fir')
```

Open a System Selector window to select a subsystem within the current model. Then open the selected subsystem into the HDL Workflow Advisor.

```
hdladvisor(gcf, 'SystemSelector')
```

Alternatives

You can also open the HDL Workflow Advisor from the your model window by clicking the **Workflow Advisor** button on the Simulink® Toolstrip.

See Also

“HDL Workflow Advisor Tasks” | “Getting Started with the HDL Workflow Advisor”

Introduced in R2010a

hdlcoder.optimizeDesign

Automatic iterative HDL design optimization

Syntax

```
hdlcoder.optimizeDesign(model, optimizationCfg)
hdlcoder.optimizeDesign(model, cpGuidanceFile)
```

Description

`hdlcoder.optimizeDesign(model, optimizationCfg)` automatically optimizes your generated HDL code based on the optimization configuration you specify.

`hdlcoder.optimizeDesign(model, cpGuidanceFile)` regenerates the optimized HDL code without rerunning the iterative optimization, by using data from a previous run of `hdlcoder.optimizeDesign`.

Examples

Maximize clock frequency

Maximize the clock frequency for a model, `sfir_fixed`, by performing up to 10 optimization iterations.

Open the model and specify the DUT subsystem.

```
model = 'sfir_fixed';
dutSubsys = 'symmetric_fir';
open_system(model);
hdlset_param(model, 'HDLSubsystem', [model, '/', dutSubsys]);
```

Set your synthesis tool and target device options.

```
hdlset_param(model, 'SynthesisTool', 'Xilinx ISE', ...
    'SynthesisToolChipFamily', 'Zynq', ...
    'SynthesisToolDeviceName', 'xc7z030', ...
    'SynthesisToolPackageName', 'fbg484', ...
    'SynthesisToolSpeedValue', '-3')
```

Enable HDL test bench generation.

```
hdlset_param(model, 'GenerateHDLTestBench', 'on');
```

Save your model.

You must save your model if you want to regenerate code later without rerunning the iterative optimizations, or resume your run if it is interrupted. When you use `hdlcoder.optimizeDesign` to regenerate code or resume an interrupted run, HDL Coder checks the model checksum and generates an error if the model has changed.

Create an optimization configuration object, `oc`.

```
oc = hdlcoder.OptimizationConfig;
```

Set the iteration limit to 10.

```
oc.IterationLimit = 10;
```

Optimize the model.

```
hdlcoder.optimizeDesign(model,oc)
```

```
hdlset_param('sfir_fixed', 'HDLSubsystem', 'sfir_fixed/symmetric_fir');
hdlset_param('sfir_fixed', 'SynthesisTool', 'Xilinx ISE');
hdlset_param('sfir_fixed', 'SynthesisToolChipFamily', 'Zynq');
hdlset_param('sfir_fixed', 'SynthesisToolDeviceName', 'xc7z030');
hdlset_param('sfir_fixed', 'SynthesisToolPackageName', 'fbg484');
hdlset_param('sfir_fixed', 'SynthesisToolSpeedValue', '-3');
```

Iteration 0

```
Generate and synthesize HDL code ...
(CP ns) 16.26 (Constraint ns) 5.85 (Elapsed s) 143.66 Iteration 1
Generate and synthesize HDL code ...
(CP ns) 16.26 (Constraint ns) 5.85 (Elapsed s) 278.72 Iteration 2
Generate and synthesize HDL code ...
(CP ns) 10.25 (Constraint ns) 12.73 (Elapsed s) 427.22 Iteration 3
Generate and synthesize HDL code ...
(CP ns) 9.55 (Constraint ns) 9.73 (Elapsed s) 584.37 Iteration 4
Generate and synthesize HDL code ...
(CP ns) 9.55 (Constraint ns) 9.38 (Elapsed s) 741.04 Iteration 5
```

Generate and synthesize HDL code ...
Exiting because critical path cannot be further improved.

Summary report: summary.html

```
Achieved Critical Path (CP) Latency : 9.55 ns Elapsed : 741.04 s
Iteration 0: (CP ns) 16.26 (Constraint ns) 5.85 (Elapsed s) 143.66
Iteration 1: (CP ns) 16.26 (Constraint ns) 5.85 (Elapsed s) 278.72
Iteration 2: (CP ns) 10.25 (Constraint ns) 12.73 (Elapsed s) 427.22
Iteration 3: (CP ns) 9.55 (Constraint ns) 9.73 (Elapsed s) 584.37
Iteration 4: (CP ns) 9.55 (Constraint ns) 9.38 (Elapsed s) 741.04
```

Final results are saved in

```
/tmp/hdlsrc/sfir_fixed/hdlexpl/Final-07-Jan-2014-17-04-41
```

Validation model: gm_sfir_fixed_vnl

Then HDL Coder stops after five iterations because the fourth and fifth iterations had the same critical path, which indicates that the coder has found the minimum critical path. The design's maximum clock frequency after optimization is $1 / 9.55$ ns, or 104.71 MHz.

Optimize for specific clock frequency

Optimize a model, `sfir_fixed`, to a specific clock frequency, 50 MHz, by performing up to 10 optimization iterations, and do not generate an HDL test bench.

Open the model and specify the DUT subsystem.

```
model = 'sfir_fixed';
dutSubsys = 'symmetric_fir';
open_system(model);
hdlset_param(model, 'HDLSubsystem', [model, '/', dutSubsys]);
```

Set your synthesis tool and target device options.

```
hdlset_param(model, 'SynthesisTool', 'Xilinx ISE', ...
                 'SynthesisToolChipFamily', 'Zynq', ...
                 'SynthesisToolDeviceName', 'xc7z030', ...
                 'SynthesisToolPackageName', 'fbg484', ...
                 'SynthesisToolSpeedValue', '-3')
```

Disable HDL test bench generation.

```
hdlset_param(model, 'GenerateHDLTestBench', 'off');
```

Save your model.

You must save your model if you want to regenerate code later without rerunning the iterative optimizations, or resume your run if it is interrupted. When you use `hdlcoder.optimizeDesign` to regenerate code or resume an interrupted run, HDL Coder checks the model checksum and generates an error if the model has changed.

Create an optimization configuration object, `oc`.

```
oc = hdlcoder.OptimizationConfig;
```

Configure the automatic iterative optimization to stop after it reaches a clock frequency of 50MHz, or 10 iterations, whichever comes first.

```
oc.ExplorationMode = ...
    hdlcoder.OptimizationConfig.ExplorationMode.TargetFrequency;
oc.TargetFrequency = 50;
oc.IterationLimit = 10; =
```

Optimize the model.

```
hdlcoder.optimizeDesign(model, oc)
```

```
hdlset_param('sfir_fixed', 'GenerateHDLTestBench', 'off');
hdlset_param('sfir_fixed', 'HDLSubsystem', 'sfir_fixed/symmetric_fir');
hdlset_param('sfir_fixed', 'SynthesisTool', 'Xilinx ISE');
hdlset_param('sfir_fixed', 'SynthesisToolChipFamily', 'Zynq');
hdlset_param('sfir_fixed', 'SynthesisToolDeviceName', 'xc7z030');
hdlset_param('sfir_fixed', 'SynthesisToolPackageName', 'fbg484');
hdlset_param('sfir_fixed', 'SynthesisToolSpeedValue', '-3');
```

```
Iteration 0
Generate and synthesize HDL code ...
(CP ns) 16.26      (Constraint ns) 20.00      (Elapsed s) 134.02 Iteration 1
Generate and synthesize HDL code ...
Exiting because constraint (20.00 ns) has been met (16.26 ns).
Summary report: summary.html
Achieved Critical Path (CP) Latency : 16.26 ns      Elapsed : 134.02 s
Iteration 0: (CP ns) 16.26      (Constraint ns) 20.00      (Elapsed s) 134.02
Final results are saved in
    /tmp/hdlsrc/sfir_fixed/hdlexpl/Final-07-Jan-2014-17-07-14
Validation model: gm_sfir_fixed_vnl
```

Then HDL Coder stops after one iteration because it has achieved the target clock frequency. The critical path is 16.26 ns, a clock frequency of 61.50 GHz.

Resume clock frequency optimization using saved data

Run additional optimization iterations for a model, `sfir_fixed`, using saved iteration data, because you terminated in the middle of a previous run.

Open the model and specify the DUT subsystem.

```
model = 'sfir_fixed';
dutSubsys = 'symmetric_fir';
open_system(model);
hdlset_param(model, 'HDLSubsystem', [model, '/', dutSubsys]);
```

Set your synthesis tool and target device options to the same values as in the interrupted run.

```
hdlset_param(model, 'SynthesisTool', 'Xilinx ISE', ...
    'SynthesisToolChipFamily', 'Zynq', ...
    'SynthesisToolDeviceName', 'xc7z030', ...
    'SynthesisToolPackageName', 'fbg484', ...
    'SynthesisToolSpeedValue', '-3')
```

Enable HDL test bench generation.

```
hdlset_param(model, 'GenerateHDLTestBench', 'on');
```

Create an optimization configuration object, `oc`.

```
oc = hdlcoder.OptimizationConfig;
```

Configure the automatic iterative optimization to run using data from the first iteration of a previous run.

```
oc.ResumptionPoint = 'Iter5-07-Jan-2014-17-04-29';
```

Optimize the model.

```
hdlcoder.optimizeDesign(model, oc)

hdlset_param('sfir_fixed', 'HDLSubsystem', 'sfir_fixed/symmetric_fir');
hdlset_param('sfir_fixed', 'SynthesisTool', 'Xilinx ISE');
hdlset_param('sfir_fixed', 'SynthesisToolChipFamily', 'Zynq');
hdlset_param('sfir_fixed', 'SynthesisToolDeviceName', 'xc7z030');
hdlset_param('sfir_fixed', 'SynthesisToolPackageName', 'fbg484');
hdlset_param('sfir_fixed', 'SynthesisToolSpeedValue', '-3');
```

```
Try to resume from resumption point: Iter5-07-Jan-2014-17-04-29
Iteration 5
```

```
Generate and synthesize HDL code ...
```

```
Exiting because critical path cannot be further improved.
```

```
Summary report: summary.html
```

```
Achieved Critical Path (CP) Latency : 9.55 ns           Elapsed : 741.04 s
Iteration 0: (CP ns) 16.26      (Constraint ns) 5.85      (Elapsed s) 143.66
Iteration 1: (CP ns) 16.26      (Constraint ns) 5.85      (Elapsed s) 278.72
Iteration 2: (CP ns) 10.25      (Constraint ns) 12.73     (Elapsed s) 427.22
Iteration 3: (CP ns) 9.55       (Constraint ns) 9.73      (Elapsed s) 584.37
Iteration 4: (CP ns) 9.55       (Constraint ns) 9.38      (Elapsed s) 741.04
```

```
Final results are saved in
```

```
    /tmp/hdlsrc/sfir_fixed/hdlexpl/Final-07-Jan-2014-17-07-30
```

```
Validation model: gm_sfir_fixed_vnl
```

Then coder stops after one additional iteration because it has achieved the target clock frequency. The critical path is 9.55 ns, or a clock frequency of 104.71 MHz.

Regenerate code using original design and saved optimization data

Regenerate HDL code using the original model, `sfir_fixed`, and saved data from the final iteration of a previous optimization run.

Open the model and specify the DUT subsystem.

```
model = 'sfir_fixed';
dutSubsys = 'symmetric_fir';
open_system(model);
hdlset_param(model, 'HDLSubsystem', [model, '/', dutSubsys]);
```

Set your synthesis tool and target device options to the same values as in the original run.

```
hdlset_param(model, 'SynthesisTool', 'Xilinx ISE', ...
    'SynthesisToolChipFamily', 'Zynq', ...
    'SynthesisToolDeviceName', 'xc7z030', ...
    'SynthesisToolPackageName', 'fbg484', ...
    'SynthesisToolSpeedValue', '-3')
```

Regenerate HDL code using saved optimization data from `cpGuidance.mat`.

```
hdlcoder.optimizeDesign(model,
    'hdlsrc/sfir_fixed/hdlexpl/Final-19-Dec-2013-23-05-04/cpGuidance.mat')
```

Final results are saved in
 /tmp/hdlsrc/sfir_fixed/hdlexpl/Final-07-Jan-2014-17-16-52
 Validation model: gm_sfir_fixed_vnl

Input Arguments

model — Model name

character vector

Model name, specified as a character vector.

Example: 'sfir_fixed'

optimizationCfg — Optimization configuration

`hdlcoder.OptimizationConfig`

Optimization configuration, specified as an `hdlcoder.OptimizationConfig` object.

cpGuidanceFile — File containing saved optimization data

' ' (default) | character vector

File that contains saved data from the final optimization iteration, including relative path, specified as a character vector. Use this file to regenerate optimized code without rerunning the iterative optimization.

The file name is `cpGuidance.mat`. You can find the file in the iteration folder name that starts with `Final`, which is a subfolder of `hdlexpl`.

Example: 'hdlexpl/Final-11-Dec-2013-23-17-10/cpGuidance.mat'

See Also

Classes

hdlcoder.OptimizationConfig

Functions

hdlcoder.supportedDevices

Topics

"Automatic Iterative Optimization"

"Tool and Device"

Introduced in R2014a

importhdl

Import Verilog code and generate Simulink model

Syntax

```
importhdl(FileNames)  
importhdl(FileNames,Name,Value)
```

Description

`importhdl` imports and parses the specified Verilog files to generate the corresponding Simulink model.

`importhdl(FileNames)` imports the specified Verilog files and generates the corresponding Simulink model while removing unconnected components that do not directly contribute to the output.

`importhdl(FileNames,Name,Value)` imports the specified Verilog files and generates the corresponding Simulink model while removing unconnected components that do not directly contribute to the output, with options specified by one or more name-value pair arguments.

Examples

Generate Simulink Model From Single Verilog File

This example shows how you can import a file containing Verilog code and generate the corresponding Simulink™ model.

Specify Input Verilog File

Make sure that the input HDL file does not contain any syntax errors, is synthesizable, and uses constructs that are supported by HDL import. This example shows a Verilog code of a comparator.

```
edit('comparator.v')
```

```
// File Name: comparator.v
// This module implements a simple comparator module

`define value 12
module comparator (clk, rst, a, b);

input clk, rst;
input [1:0] a;
output reg [1:0] b;

parameter d = 2'b11;

always@(posedge clk) begin
    if (rst)
        b <= 0;
    else if (a < `value)
        b <= a + 1;
end

endmodule
```

Import Verilog File

To import the HDL file and generate the Simulink™ model, pass the file name as a character vector to the `importhdl` function.

```
importhdl('comparator.v')
```

```
### Parsing <a href="matlab:edit('comparator.v')">comparator.v</a>.
### Top Module of the source: 'comparator'.
### Identified ClkName::clk.
### Identified RstName::rst.
### Hdl Import parsing done.
### Creating Target model comparator
### Generating Dot Layout...
### Start Layout...
### Working on hierarchy at ---> 'comparator'.
### Laying out components.
### Working on hierarchy at ---> 'comparator/comparator'.
### Laying out components.
### Applying Dot Layout...
### Drawing block edges...
### Applying Dot Layout...
### Drawing block edges...
### Setting the model parameters.
### Generated model as C:\Temp\examples\examples\hdlcoder-ex77699673\hdlimport\comparator\comparat
### HDL Import completed.
```

HDL import parses the input file and displays messages of the import process in the MATLAB™ Command Window. The import provides a link to the generated Simulink™ model `comparator.slx`. The generated model uses the same name as the top module in the input Verilog file.

Examine Generated Simulink™ Model

To open the generated Simulink™ model, select the link. The model is saved in the `hdlimport/comparator` path relative to the current folder. You can simulate the model and observe the simulation results.

```
addpath('hdlimport/comparator')
open_system('comparator.slx')
sim('comparator.slx')
```

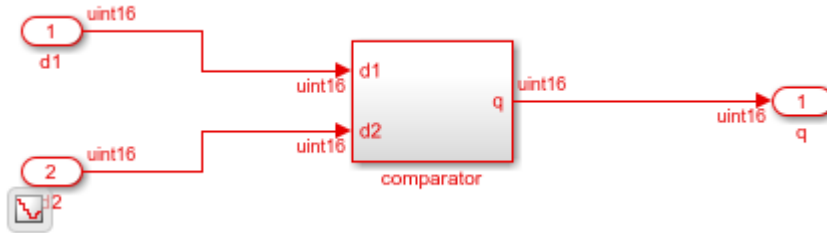

Generate Simulink Model From Multiple Verilog Files

This example shows how you can import multiple files containing Verilog code and generate the corresponding Simulink™ model.

Specify input Verilog File

Make sure that the input HDL files do not contain any syntax errors, are synthesizable, and use constructs that are supported by HDL import. For example, this code shows three Verilog files that use module instantiation to form a hierarchical design. One module `example1.v` implements a simple sequential circuit based on an if-else condition. The other module `example2.v` implements a simple combinational arithmetic expression.

```
edit('example1.v')
edit('example2.v')
```

```
// File Name: example1.v
// This module implements a sequential circuit that
// adds two inputs or multiplies one of the inputs by a factor
// based on a conditional.

module example1(clk, cond, y, a, b);

input clk, cond;
input [7:0] a, b;
output reg [7:0] y;

parameter g = 8'd5;

always@(posedge clk)
    if (cond == 1'b1) y <= a + b;
    else             y <= a * g;

endmodule

// File Name: example2.v
// This module implements a combinational arithmetic expression
module example2(c, d, e, f, y2);

input [7:0] c, d, e, f;
output [7:0] y2;

assign y2 = (c + d) * e / f;

endmodule
```

A top module contained in file `example.v` instantiates the two modules in `example1.v` and `example2.v`

```
edit('example.v')
```

```

// File Name: example.v
// This is the top-level module
module example(clk, cond, a, b, c, d, e, f, y, y2);

input clk;
input cond;
input [7:0] a, b, c, d, e, f;
output [7:0] y;
output [7:0] y2;

example1 example1(.clk(clk), .a(a), .cond(cond), .b(b), .y(y));

example2 example2(.c(c), .d(d), .e(e), .f(f), .y2(y2));

endmodule

```

Import Verilog Files

To import the HDL file and generate the Simulink™ model, pass the file names as a cell array of character vectors to the `importhdl` function. By default, HDL import identifies the top module and clock bundle when parsing the input file.

```
importhdl({'example.v', 'example1.v', 'example2.v'})
```

```

### Parsing <a href="matlab:edit('example.v')">example.v</a>.
### Parsing <a href="matlab:edit('example1.v')">example1.v</a>.
### Parsing <a href="matlab:edit('example2.v')">example2.v</a>.
### Top Module of the source: 'example'.
### Identified ClkName::clk.
### Hdl Import parsing done.
### Creating Target model example
### Generating Dot Layout...
### Start Layout...
### Working on hierarchy at ---> 'example'.
### Laying out components.
### Working on hierarchy at ---> 'example/example'.
### Laying out components.
### Working on hierarchy at ---> 'example/example/example1'.
### Laying out components.
### Applying Dot Layout...
### Drawing block edges...
### Working on hierarchy at ---> 'example/example/example2'.
### Laying out components.
### Applying Dot Layout...
### Drawing block edges...
### Applying Dot Layout...
### Drawing block edges...
### Applying Dot Layout...
### Drawing block edges...
### Setting the model parameters.
### Generated model as C:\Temp\examples\examples\hdlcoder-ex56732899\hdlimport\example\example.s
### HDL Import completed.

```

HDL import parses the input file and displays messages of the import process in the MATLAB™ Command Window. The import provides a link to the generated Simulink™ model `example.slx`. The generated model uses the same name as the top module that is contained in the input Verilog file `example1.v`.

Examine Generated Simulink™ Model

To open the generated Simulink™ model, select the link. The model is saved in the `hdlimport/example` path relative to the current folder. You can simulate the model and observe the simulation results.

```
addpath('hdlimport/example')
open_system('example.slx')
```

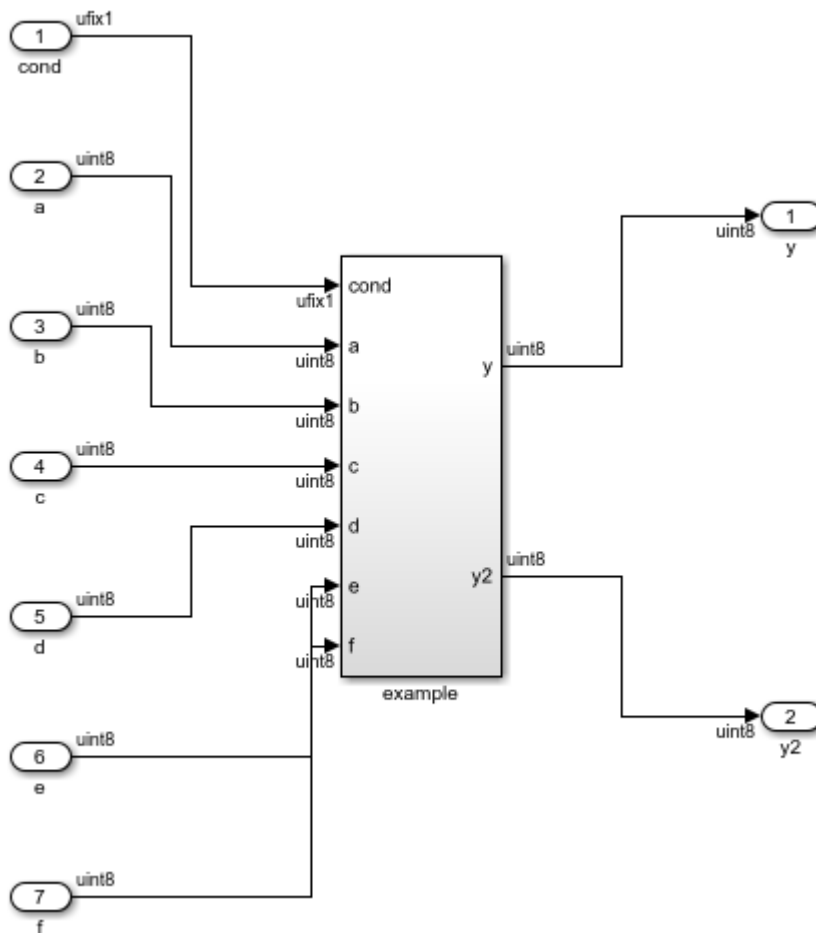

To avoid a division by zero, you can suppress the warning diagnostic before simulation.

```
Simulink.suppressDiagnostic({'example/example/example2/Div'}, ...
    'SimulinkFixedPoint:util:fxpDivisionByZero')
sim('example')
```

You can see the hierarchy of Subsystems that implement the Verilog code that uses module instantiation.

```
open_system('example/example/example1')
```

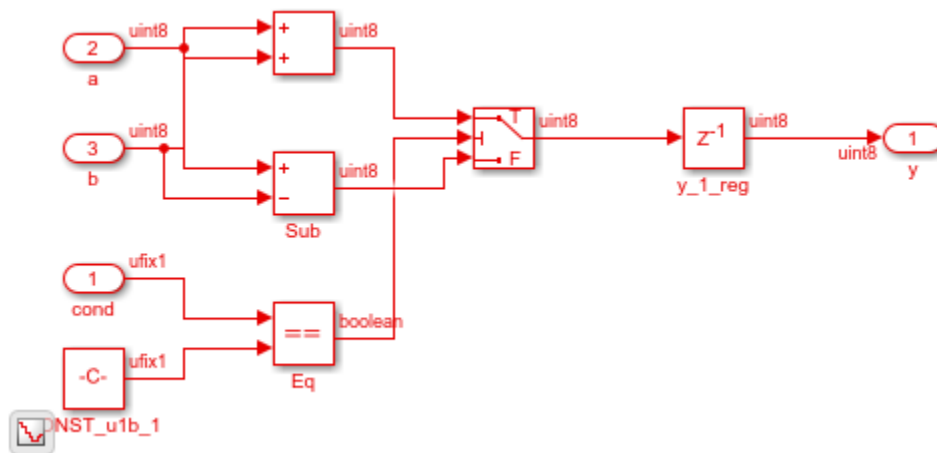

```
open_system('example/example/example2')
```

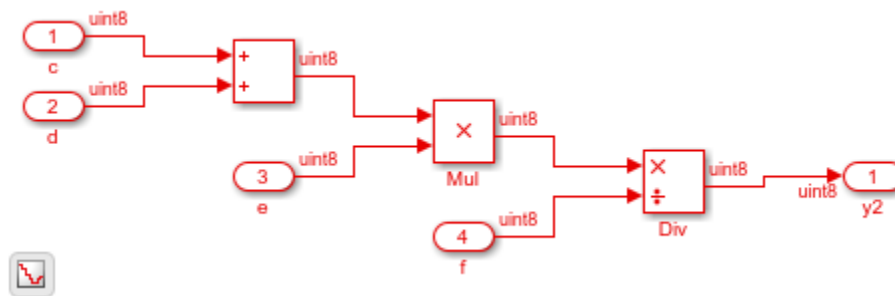

Generate Simulink Model From Verilog Files with BlackBox Modules

This example shows how you can import multiple files containing Verilog code and generate the corresponding Simulink™ model. When you import multiple files, if you want to obfuscate the HDL code or if your files contain HDL code for vendor-specific IPs, you can import the HDL code as a BlackBox module using the `importhdl` function.

Specify input Verilog Files

Make sure that the input HDL files do not contain any syntax errors, are synthesizable, and use constructs that are supported by HDL import. For example, this code shows three Verilog files that use module instantiation to form a hierarchical design. One module `sequentialexp.v` implements a simple sequential circuit based on an if-else condition. The other module `conditionalcomb.v` implements a simple combinational arithmetic expression.

```
edit('conditionalcomb.v')
edit('sequentialexp.v')
edit('intelip.v')
```

```
// File Name: conditionalcomb.v
// This module implements a sequential circuit that
// adds or subtracts two inputs based on a conditional.

module conditionalcomb(clk, cond, y, a, b);

input clk, cond;
input [7:0] a, b;
output reg [7:0] y;

always@(posedge clk)
    if (cond == 1'b1) y <= a + b;
    else y <= a - b;

endmodule

// File Name: sequentialexp.v
// This module implements a combinational arithmetic expression

module sequentialexp(a, b, c, d, e, f, y1, y2);

input a, b;
input [7:0] c, d, e, f;
output [7:0] y1;
output y2;

assign y1 = (c + d) * e / f;

//Instantiate Intel Vendor IP
intelip u_intelip(.dataa(a), .datab(b), .datac(y2));

endmodule
```

See that the `sequentialexp.v` module instantiates an Intel® IP that implements a single-precision floating-point adder.

```

// This module is the Intel IP that implements a
// single-precision floating-point adder.
module intelip(dataa, datab, datac);

input dataa, datab;
output datac;

assign datac = dataa + datab;

endmodule

```

A top module top contained in file blackboxtop.v instantiates the two modules in conditionalcomb.v and sequentialexp.v

```
edit('blackboxtop.v')
```

```

// File Name: blackboxtop.v
// This is the top-level module that instantiates
// modules example1 and example2.
module top(clk, cond, a, b, c, d, e, f, g, h, y, y1, y2);

input clk, cond, g, h;
input [7:0] a, b, c, d, e, f;
output [7:0] y, y1;
output y2;

conditionalcomb u_comb(.clk(clk), .a(a), .cond(cond), .b(b), .y(y));

sequentialexp u_seq(.a(g), .b(h), .c(c), .d(d), .e(e), .f(f), .y1(y1), .y2(y2));

endmodule

```

Import Verilog Files

To import the HDL file and generate the Simulink™ model, pass the file names as a cell array of character vectors to the importhdl function. By default, HDL import identifies the top module and clock bundle when parsing the input file.

```

importhdl({'blackboxtop.v', 'conditionalcomb.v', 'sequentialexp.v', 'intelip.v'}, ...
          'topModule', 'top', 'blackBoxModule', 'intelip')

### Parsing <a href="matlab:edit('blackboxtop.v')">blackboxtop.v</a>.
### Parsing <a href="matlab:edit('conditionalcomb.v')">conditionalcomb.v</a>.
### Parsing <a href="matlab:edit('sequentialexp.v')">sequentialexp.v</a>.
### Parsing <a href="matlab:edit('intelip.v')">intelip.v</a>.
### Top Module of the source: 'top'.

```

```
### Identified ClkName::clk.
### Hdl Import parsing done.
### Creating Target model top
### Generating Dot Layout...
### Start Layout...
### Working on hierarchy at ---> 'top'.
### Laying out components.
### Working on hierarchy at ---> 'top/top'.
### Laying out components.
### Working on hierarchy at ---> 'top/top/u_comb'.
### Laying out components.
### Applying Dot Layout...
### Drawing block edges...
### Working on hierarchy at ---> 'top/top/u_seq'.
### Laying out components.
### Working on hierarchy at ---> 'top/top/u_seq/u_intelip'.
### Laying out components.
### Applying Dot Layout...
### Drawing block edges...
### Applying Dot Layout...
### Drawing block edges...
### Applying Dot Layout...
### Drawing block edges...
### Applying Dot Layout...
### Drawing block edges...
### Setting the model parameters.
### Generated model as C:\Temp\examples\examples\hdlcoder-ex63017378\hdlimport\top\top.slx.
### HDL Import completed.
```

HDL import parses the input file and displays messages of the import process in the MATLAB™ Command Window. The import provides a link to the generated Simulink™ model `top.slx`. The generated model uses the same name as the top module that is contained in the input Verilog file `conditionalcomb.v`.

Examine Generated Simulink™ Model

To open the generated Simulink™ model, select the link. The model is saved in the `hdlimport/top` path relative to the current folder. You can simulate the model and observe the simulation results.

```
addpath('hdlimport/top')
open_system('top.slx')
set_param('top', 'SimulationCommand', 'update')
```

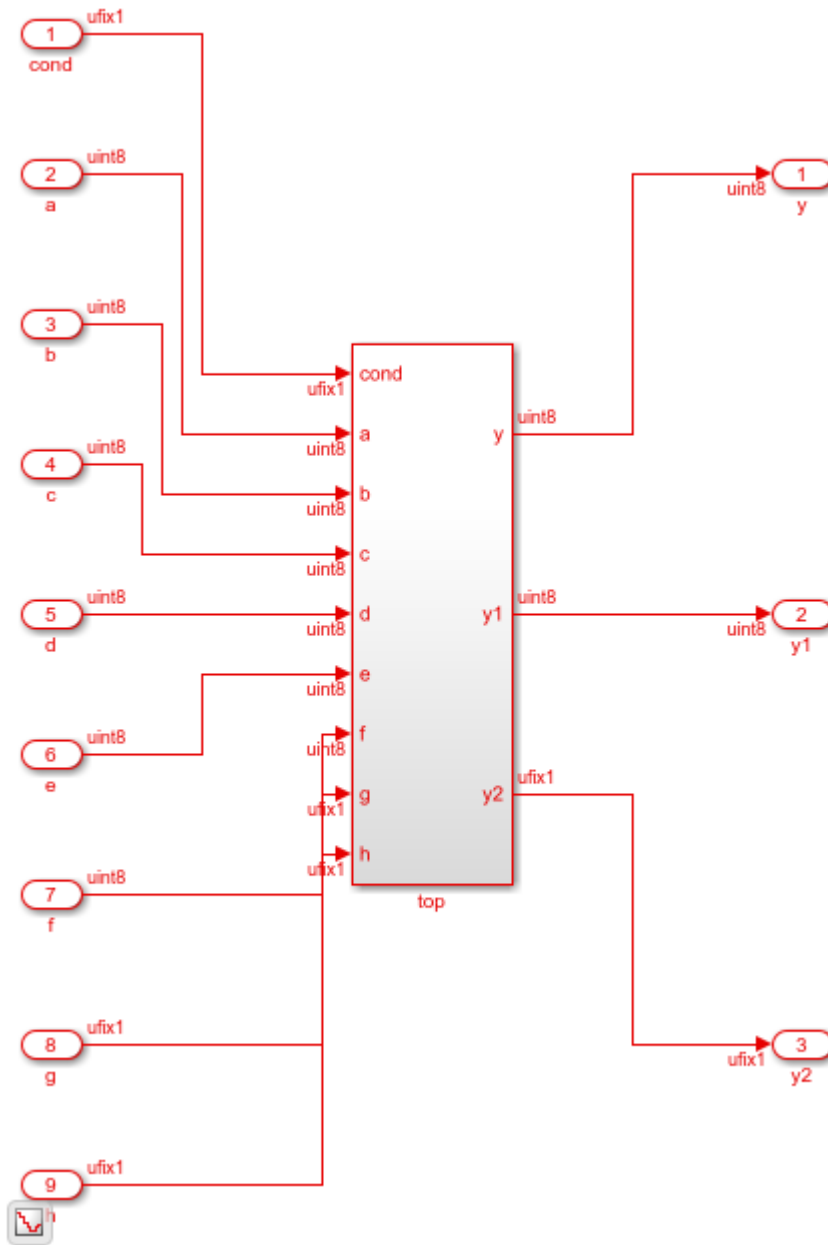

To avoid a division by zero, you can suppress the warning diagnostic before simulation.

```
Simulink.suppressDiagnostic({'top/top/u_seq/Div'}, ...
    'SimulinkFixedPoint:util:fxpDivisionByZero')
sim('top')
```

You can see the hierarchy of Subsystems that implement the Verilog code that uses module instantiation.

```
open_system('top/top/u_comb')
```

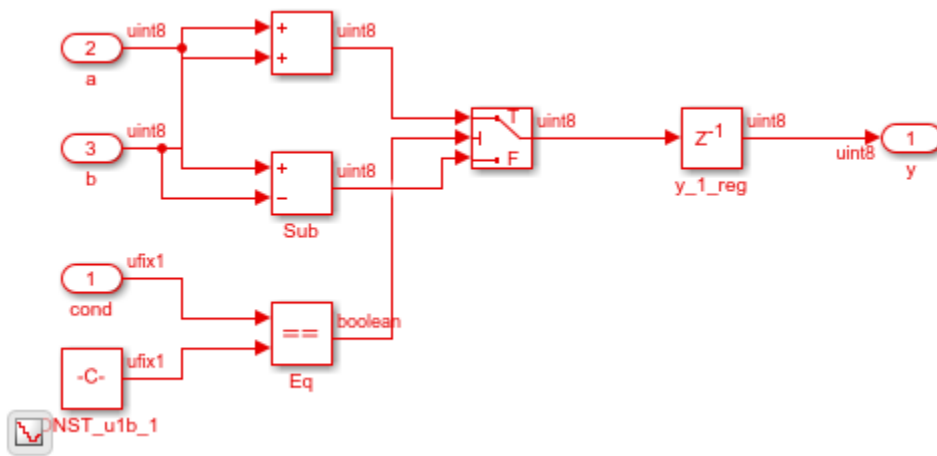

If you open the Subsystem that implements the sequential circuit, you can open the `u_intelip` Subsystem to see the blackbox implementation.

`open_system('top/top/u_seq')`

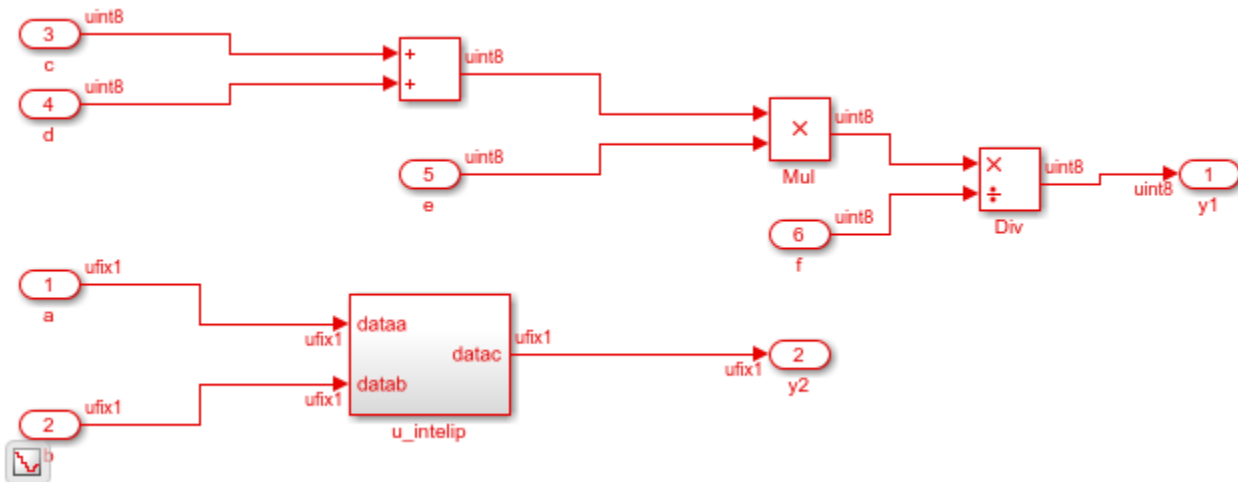

`open_system('top/top/u_seq/u_intelip')`

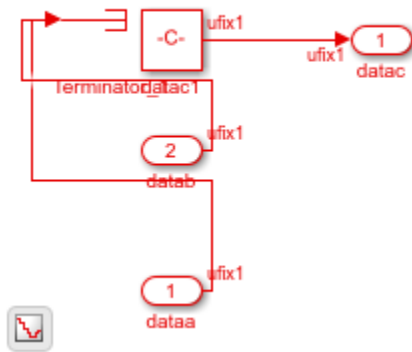

Generate Simulink Model from Verilog Code for Various Operators

This example shows how you can import Verilog code that contains these operators and generate the corresponding Simulink™ model:

- Arithmetic
- Logical
- XOR
- Bitwise
- Conditional
- Relational
- Concatenation

Specify Input Verilog File

Make sure that the input HDL file does not contain any syntax errors, is synthesizable, and uses constructs for the various operators. For example, this Verilog code shows various operators.

```
edit('VerilogOperators.v')
```

```

`timescale 1 ns / 1 ns

module VerilogOperators (A, B, C, D, Y1, Y2, Y3, Y4, Y5, Y6);

    input    [7:0] A, B;
    input    C, D;
    output reg [7:0] Y1, Y2;
    output reg Y3, Y4;
    output reg [15:0] Y5;
    output [7:0] Y6;

    always @(A or B or C or D) begin

        Y1 = A % B;                // Arithmetic remainder operator
        Y2 = B >> 4;              // Logical shift right operator
        Y3 = C ^ D;               // Reduction XOR operator
        Y4 = A <= B;              // Relational operator
        Y5 = {A, D, {2{3'b011}}, 1'b0}; // Concatenation operator

    end

    assign Y6[7:0] = (C == 1'b1) ? A : B; // Conditional operator

endmodule

```

Import Verilog File

To import the HDL file and generate the Simulink™ model, pass the file name as a character vector to the `importhdl` function.

```

importhdl('VerilogOperators.v')

### Parsing <a href="matlab:edit('VerilogOperators.v')">VerilogOperators.v</a>.
### Top Module of the source: 'VerilogOperators'.
### HdL Import parsing done.
### Creating Target model VerilogOperators
### Generating Dot Layout...
### Start Layout...
### Working on hierarchy at ---> 'VerilogOperators'.
### Laying out components.
### Working on hierarchy at ---> 'VerilogOperators/VerilogOperators'.
### Laying out components.
### Applying Dot Layout...
### Drawing block edges...
### Applying Dot Layout...
### Drawing block edges...
### Generated model as C:\Temp\examples\examples\hdlcoder-ex29847655\hdlimport\VerilogOperators\
### HDL Import completed.

```

HDL import parses the input file and displays messages of the import process in the MATLAB™ Command Window. The import provides a link to the generated Simulink™ model

VerilogOperators.slx. The generated model uses the same name as the top module in the input Verilog file.

Examine Generated Simulink™ Model

To open the generated Simulink™ model, select the link. The model is saved in the hdlimport/VerilogOperators path relative to the current folder. You can simulate the model and observe the simulation results.

```
addpath('hdlimport/VerilogOperators')
open_system('VerilogOperators.slx')
sim('VerilogOperators.slx')
```

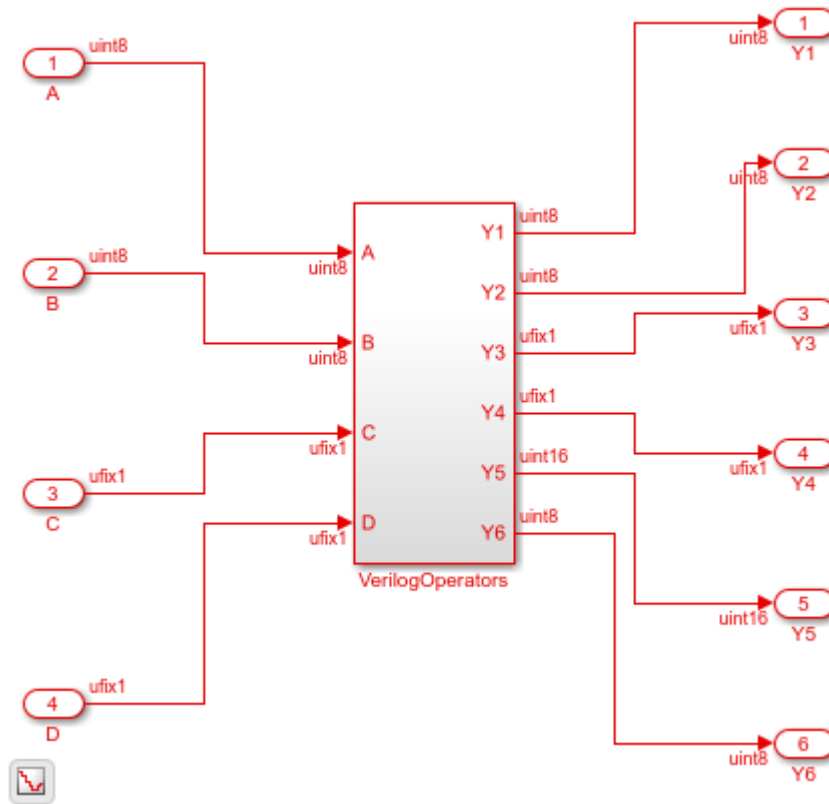

Implicit Data Type Conversion when Importing Verilog Code

This example shows how you can import multiple files containing Verilog code that perform implicit data type conversions and generate the corresponding Simulink™ model. HDL import can perform implicit data type conversion such as in arithmetic operations, data type conversion, bit selection, and bit concatenation.

Specify input Verilog File

Make sure that input HDL files do not contain any syntax errors, are synthesizable, and use constructs that are supported by HDL import. For example, this code shows three Verilog files that use module instantiation to form a hierarchical design. The modules NG1_implicit.v and round_const.v perform implicit data type conversion.

```
edit('NG1_implicit.v')
edit('round_constant.v')

module NG1(IN_A, IN_B, OUT_A);

input [4:0] IN_A;
input IN_B;
output OUT_A;

parameter IN_B_AND = 5'b10011;

assign OUT_A = IN_A == IN_B_AND & IN_B;

endmodule

/* round constant */
module rconst(i,rc);

input [23:0] i;
output reg [63:0] rc;

always@(i) begin
    rc = 0;
end

endmodule
```

A top module contained in file `example.v` instantiates the two modules in `NG1_implicit.v` and `round_constant.v`.

```
edit('implicit_top.v')
```

```

// File Name: implicit_top.v
// This is the top-level module that instantiates
// modules NG1_implicit and round_constant.
module top(A, B, C, Y1, Y2);

    input [4:0] A;
    input B;
    input [23:0] C;
    output Y1, Y2;

    NG1 NG1(A, B, Y1);

    rconst rconst(C, Y2);

endmodule

```

Import Verilog Files

To import the HDL file and generate the Simulink™ model, pass the file names as a cell array of character vectors to the `importhdl` function. By default, HDL import identifies the top module when parsing the input file.

```
importhdl({'implicit_top.v','NG1_implicit.v','round_constant.v'})
```

```

### Parsing <a href="matlab:edit('implicit_top.v')">implicit_top.v</a>.
### Parsing <a href="matlab:edit('NG1_implicit.v')">NG1_implicit.v</a>.
### Parsing <a href="matlab:edit('round_constant.v')">round_constant.v</a>.
### Top Module name: 'top'.

```

```
Warning: Unused input port 'i' in 'rconst' module.
```

```
### HdL Import parsing done.
```

```
### Creating Target model top
```

```
### Generating Dot Layout...
```

```
### Start Layout...
```

```
### Working on hierarchy at ---> 'top'.
```

```
### Laying out components.
```

```
### Working on hierarchy at ---> 'top/top'.
```

```
### Laying out components.
```

```
### Working on hierarchy at ---> 'top/top/NG1'.
```

```
### Laying out components.
```

```
Configurable Subsystem block 'simulink/Ports & Subsystems/Configurable Subsystem' must be converted to a block.
```

```
### Applying Dot Layout...
```

```
### Drawing block edges...
```

```
### Working on hierarchy at ---> 'top/top/rconst'.
```

```
### Laying out components.
```

```
### Applying Dot Layout...
```

```
### Drawing block edges...
```

```
### Applying Dot Layout...
```

```
### Drawing block edges...
```

```
### Applying Dot Layout...
```

```
### Drawing block edges...
```

```
### Generated model file C:\TEMP\Examples\hdlcoder-ex12503110\hdlimport\top\top.slx.
```

```
### Importhdl completed.
```

HDL import parses the input file and displays messages of the import process in the MATLAB™ Command Window. The import provides a link to the generated Simulink™ model `implicit_top.slx`. The generated model uses the same name as the top module that is contained in the input Verilog file `implicit_top.v`.

Examine Generated Simulink™ Model

To open the generated Simulink™ model, select the link. The model is saved in the `hdlimport/example` path relative to the current folder. You can simulate the model and observe the simulation results.

```
addpath('hdlimport/top');
open_system('top.slx')
```

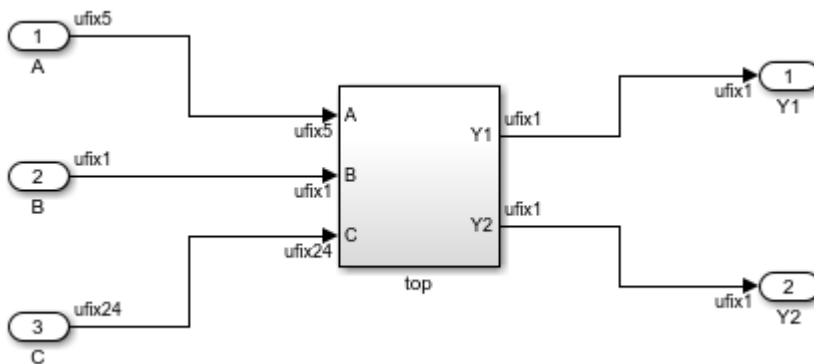

In the `rconst` Subsystem, one of the input ports is unconnected. It is good practice to avoid unterminated outputs by adding a Terminator block.

```
addterms('top');
sim('top');
```

You can see the hierarchy of Subsystems that implement the Verilog code that uses module instantiation.

```
open_system('top/top/NG1')
```

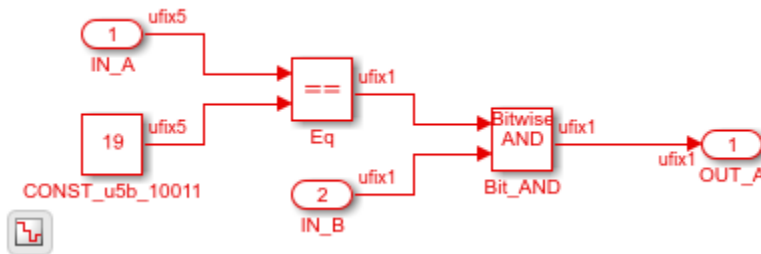

```
open_system('top/top/rconst')
```

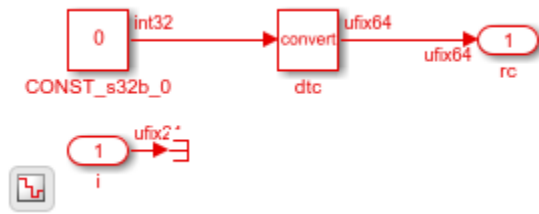

Generate Simulink Model from Verilog Code That Infers RAMs

This example shows how you can import a file containing Verilog code and infer RAM blocks in the Simulink™ model that gets generated. You can import Verilog code that infers any of the various RAMs in the HDL RAMs library including the hdl.RAM System-Object based blocks and Block RAMs.

Specify Input Verilog File

Make sure that the input HDL file does not contain any syntax errors, is synthesizable, and uses constructs that are supported by HDL import. This example shows the Verilog code.

```
edit('simple_dual_port_ram.v')
```

```

//Inference of Multiple RAMs
`timescale 1 ns / 1 ns

module SimpleDualPortRAM (clk, enb,
    wr_din, wr_addr, wr_en,
    rd_addr, rd_dout1, rd_dout2);

    input    clk, enb;
    input    [15:0] wr_din;
    input    [7:0] wr_addr, rd_addr;
    input    wr_en;
    output   [15:0] rd_dout;

    reg [7:0] raml[7:0], ram2[7:0];

    // This is the first RAM block
    always @(posedge clk) begin
        if (enb) begin
            if (wr_en) begin
                raml[wr_addr] <= wr_din;
            end
            rd_out1 <= raml[rd_addr];
        end
    end

    // This is the second RAM block
    always @(posedge clk) begin
        if (enb) begin
            if (wr_en) begin
                ram2[wr_addr] <= wr_din;
            end
            rd_out2 <= raml[rd_addr];
        end
    end

endmodule

```

Import Verilog File

To import the HDL file and generate the Simulink™ model, pass the file name as a character vector to the `importhdl` function.

```

importhdl('simple_dual_port_ram.v')

### Parsing <a href="matlab:edit('simple_dual_port_ram.v')">simple_dual_port_ram.v</a>.
### Top Module name: 'SimpleDualPortRAM'.
### Identified ClkName::clk.

```

```

### Hdl Import parsing done.
### Creating Target model SimpleDualPortRAM
### Generating Dot Layout...
### Start Layout...
### Working on hierarchy at ---> 'SimpleDualPortRAM'.
### Laying out components.
### Working on hierarchy at ---> 'SimpleDualPortRAM/SimpleDualPortRAM'.
### Laying out components.
Configurable Subsystem block 'simulink/Ports & Subsystems/Configurable Subsystem' must be converted to a block.

### Applying Dot Layout...
### Drawing block edges...
### Applying Dot Layout...
### Drawing block edges...
### Setting model parameters.
### Generated model file C:\TEMP\Examples\hdlcoder-ex67646187\hdlimport\SimpleDualPortRAM\SimpleDualPortRAM.slx
### Importhdl completed.

```

HDL import parses the input file and displays messages of the import process in the MATLAB™ Command Window. The import provides a link to the generated Simulink™ model SimpleDualPortRAM.slx. The generated model uses the same name as the top module in the input Verilog file.

Examine Generated Simulink™ Model

To open the generated Simulink™ model, select the link. The model is saved in the hdlimport/SimpleDualPortRAM path relative to the current folder. You can simulate the model and observe the simulation results.

```

addpath('hdlimport/SimpleDualPortRAM');
open_system('SimpleDualPortRAM.slx');
sim('SimpleDualPortRAM.slx');

```

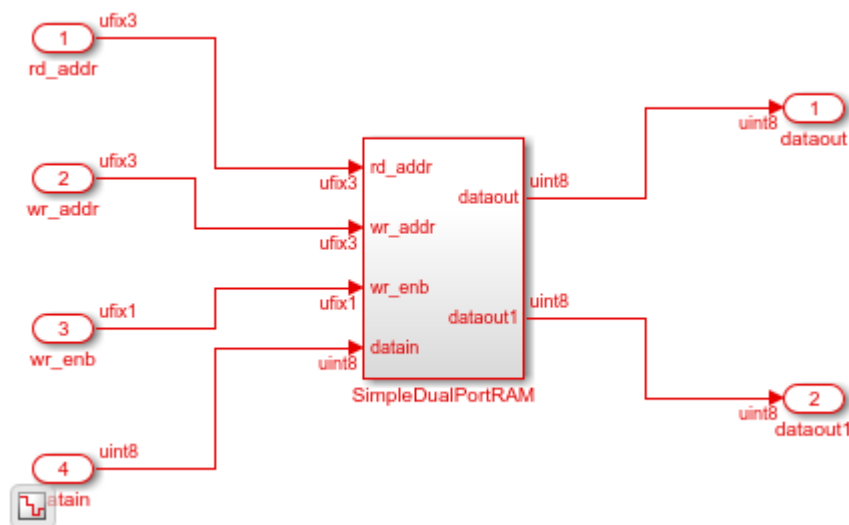

If you navigate the model, you see the Simple Dual Port RAM block.

```

open_system('SimpleDualPortRAM/SimpleDualPortRAM')

```

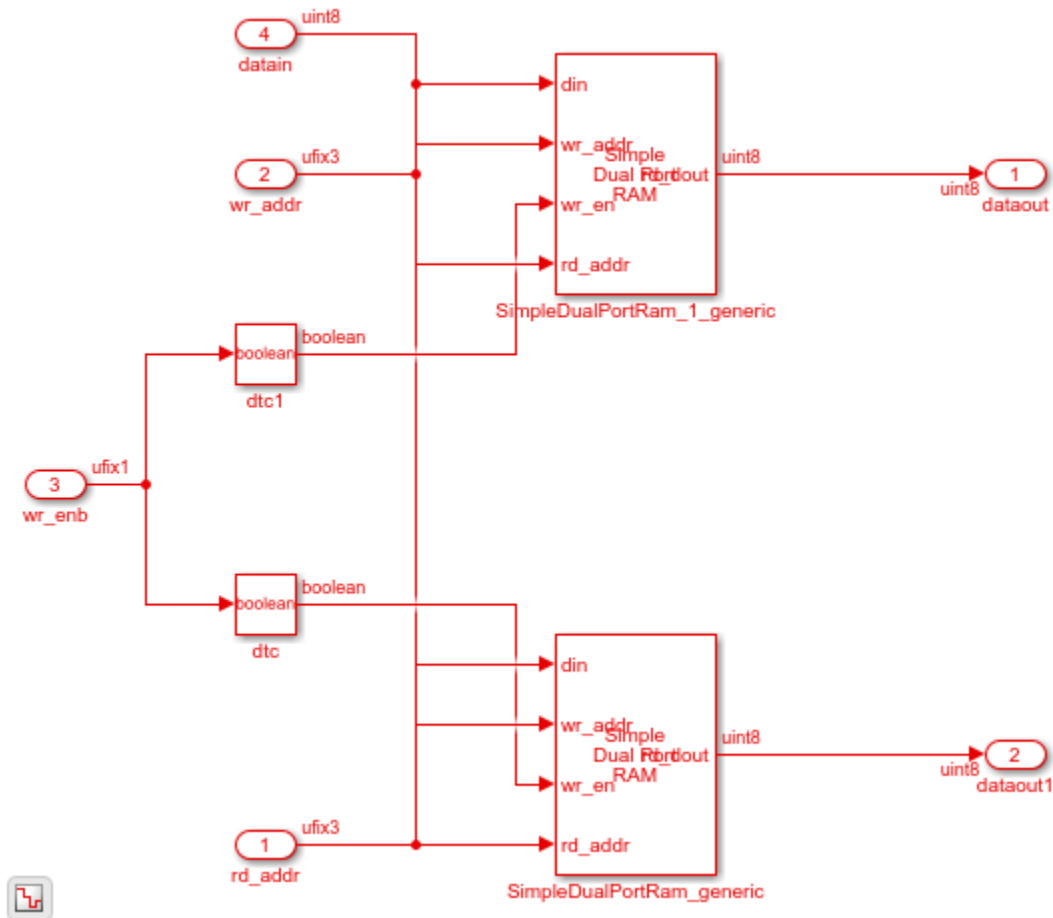

Input Arguments

FileNames – Names of HDL files to import

'Filename' | {'Filename1','Filename2',...,'FilenameN'} | 'Foldername'

Names of HDL files to import for generation of the Simulink model. By default, `importhdl` imports Verilog files. To import:

- One HDL file, specify the file name as a character vector.
- Multiple HDL files, specify the file names as a cell array of character vectors.
- All HDL files in a folder, specify the folder name as a character vector.
- Multiple folders and combinations of files and folders, specified as cell array of character vectors. You can also use subfolders that contain recursive folders.

Example: `importhdl('example')` imports the specified Verilog file. If `example` is a subfolder in the current working folder, HDL import parses that file and module instantiations inside subfolders, and then generates a Simulink model for all `.v` files. If `importhdl` cannot find a subfolder that has the name `example`, it searches the MATLAB path for HDL files that have the name `example`.

Example: `importhdl({'top.v','subsystem1.v','subsystem2.v'})` imports the specified Verilog files and generates the corresponding Simulink model.

Example: `importhdl(pwd)` imports all Verilog files in the current folder and generates the corresponding Simulink model.

Example: `importhdl('root/example/hdlsrc')` imports all Verilog files on the specified path and generates the corresponding Simulink model. You can specify a relative or absolute path.

Example: `importhdl('subfolder')` imports all Verilog files under specified subfolder and generates the corresponding Simulink model. By default, `importhdl` parses subfolders that contain recursive folders.

Name-Value Pair Arguments

Specify optional comma-separated pairs of `Name`, `Value` arguments. `Name` is the argument name and `Value` is the corresponding value. `Name` must appear inside quotes. You can specify several name and value pair arguments in any order as `Name1, Value1, . . . , NameN, ValueN`.

Example: `importhdl('root/example/hdlsrc')` imports all Verilog files in the specified path and generates the corresponding Simulink model. You can specify a relative or absolute path.

Language — Language of input HDL file

'Verilog' (default)

Language of input source file that contains the HDL code, specified as a character vector. If you specified a VHDL file, HDL import generates an error.

Example: `importhdl('fifo.v', 'Language', 'Verilog')` imports the Verilog file `fifo.v` and generates the corresponding Simulink model `fifo.slx`.

topModule — Name of top module or entity

Identified by parsing input file (default) | character vector | string scalar

Top-level module name in the HDL code, specified as a character vector. This name becomes the name of the top-level Subsystem from which HDL import constructs the hierarchy of subsystems in the generated Simulink model. If the input HDL files contain more than one top module, specify the top-level module to use for generating the Simulink model by using the `TopModule` property.

Example: `importhdl('full_adder.v', 'TopModule', 'two_half_adders')` imports the Verilog file `full_adder.v` and generates the corresponding Simulink model `full_adder.slx` with `two_half_adders` as the top-level Subsystem.

clockBundle — Clock bundle names

{'clock', 'reset', 'enable'} (default) | cell array of character vectors

Names of clock, reset, and clock enable signals for sequential circuits, specified as a cell array of character vector. Default names for the clock bundle signals are:

- Clock signal - `clk`, `clock`
- Reset signal - `rst`, `reset`
- Clock Enable signal - `clk_enb`, `clk_en`, `clk_enable`, `enb`, `enable`

If you do not specify the clock bundle information, HDL import uses the default values. When parsing the input file, if HDL import identifies a clock name that is different from the clock name specified by the `ClockBundle`, the import generates an error.

Example: `importhdl('example.v', 'clockBundle', {'clk', 'rst', 'clk_enb'})` imports the Verilog file `example.v` with the specified clock bundle information.

blackBoxModule — BlackBox module names`' ' (default) | character vector | cell array of character vectors`

Name or names of modules in the Verilog input files to be imported as BlackBox subsystems in the generated Simulink model. The Subsystem block that is imported as BlackBox uses the input and output ports that you provide to the module definition. Inside the Subsystem, the input ports are connected to Terminator blocks, Constant blocks with a value of zero are connected to the output ports. Use this capability to import vendor-specific IPs as BlackBox subsystems in your model.

Example:

`importhdl({'example.v','example1.v','example2.v','xilinxIP.v'},'topModule','top','blackBoxModule','xilinxIP')` imports the specified Verilog files with `xilinxIP` as a BlackBox module. The corresponding Subsystem in the Simulink model has the input ports connected to Terminator blocks and Constant blocks with constant value of zero connected to the output ports.

autoPlace — Arrange blocks for improved layout`'on' (default) | 'off'`

Automatically arrange blocks in the Simulink model generated by running `importhdl`. By default, `autoPlace` is on. `importhdl` then uses `Simulink.BlockDiagram.arrangeSystem` to improve the model layout by realigning, resizing, and moving blocks, and straightening signal lines.

Example: `importhdl('example.v','autoPlace','on')` imports the Verilog file `example.v` and generates the Simulink model with an enhanced model layout.

See Also`checkhdl | makehdl`**Topics**

“Generate Simulink® Model From CORDIC Atan2 Verilog® Code”

“Import Verilog Code and Generate Simulink Model”

“Supported Verilog Constructs for HDL Import”

“Verilog Dataflow Modeling with HDL Import”

Introduced in R2018b

hdlcoder.supportedDevices

Show supported target hardware and device details

Syntax

```
hdlcoder.supportedDevices
```

Description

`hdlcoder.supportedDevices` shows a link to a report that contains the device and device property names for target devices supported by your synthesis tool.

You can use the supported target device information to set `SynthesisToolChipFamily`, `SynthesisToolDeviceName`, `SynthesisToolPackageName`, and `SynthesisToolSpeedValue` for your model.

To see the report link, you must have a synthesis tool set up. If you have more than one synthesis tool available, you see a different report link for each synthesis tool.

Examples

Set the target device for your model

In this example, you set the target device for a model, `sfir_fixed`. Two synthesis tools are available, Altera® Quartus II and Xilinx® ISE. The target device is a Xilinx Virtex-6 XC6VLX130T FPGA.

Show the supported target device reports.

```
hdlcoder.supportedDevices
```

```
Altera QUARTUS II Device List
Xilinx ISE Device List
```

Click the `Xilinx ISE Device List` link to open the supported target device report and view details for your target device.

Open the model, `sfir_fixed`.

```
sfir_fixed
```

Set the `SynthesisToolChipFamily`, `SynthesisToolDeviceName`, `SynthesisToolPackageName`, and `SynthesisToolSpeedValue` model parameters based on details from the supported target device report.

```
hdlset_param('sfir_fixed',
             'SynthesisToolChipFamily','Virtex6',
             'SynthesisToolDeviceName','xc6vlx130t',
             'SynthesisToolPackageName','ff484',
             'SynthesisToolSpeedValue','-1')
```

View the nondefault parameters for your model, including target device information.

hdldispmdlparams

```
%%%%%%%%%%%%%%%%%%%%%%%%%%%%%%%%%%%%%%%%%%%%%%%%%%%%%%%%%  
HDL CodeGen Parameters (non-default)  
%%%%%%%%%%%%%%%%%%%%%%%%%%%%%%%%%%%%%%%%%%%%%%%%%%%%%%%%%
```

```
SynthesisTool           : 'Xilinx ISE'  
SynthesisToolChipFamily : 'Virtex6'  
SynthesisToolDeviceName : 'xc6vlx130t'  
SynthesisToolPackageName : 'ff484'  
SynthesisToolSpeedValue  : -1
```

See Also

Topics

“Synthesis Tool Path Setup”

“Tool and Device”

Introduced in R2014a

hdldispblkparams

Display HDL block parameters with nondefault values

Syntax

```
hdldispblkparams(path)
hdldispblkparams(path, 'all')
```

Description

`hdldispblkparams(path)` displays, for the specified block, the names and values of HDL parameters that have nondefault values.

`hdldispblkparams(path, 'all')` displays, for the specified block, the names and values of all HDL block parameters.

Input Arguments

path

Path to a block or subsystem in the current model.

Default: None

'all'

If you specify 'all', `hdldispblkparams` displays the names and values of all HDL properties of the specified block.

Examples

The following example displays nondefault HDL block parameter settings for a Sum of Elements block).

```
hdldispblkparams('simplevectorsum/vsum/Sum of Elements')
%%%%%%%%%%%%%%%%%%%%%%%%%%%%%%%%%%%%%%%%%%%%%%%%%%%%%%%%%%%%%%%%%%%%%%%%
HDL Block Parameters ('simplevectorsum/vsum/Sum of Elements')
%%%%%%%%%%%%%%%%%%%%%%%%%%%%%%%%%%%%%%%%%%%%%%%%%%%%%%%%%%%%%%%%%%%%%%%%
Implementation
  Architecture : Linear
Implementation Parameters
  InputPipeline : 1
```

The following example displays HDL block parameters and values for the currently selected block, (a Sum of Elements block).

```
hdldispblkparams(gcf, 'all')
%%%%%%%%%%%%%%%%%%%%%%%%%%%%%%%%%%%%%%%%%%%%%%%%%%%%%%%%%%%%%%%%%%%%%%%%
HDL Block Parameters ('simplevectorsum/vsum/Sum of
Elements')
```

%%%

Implementation

Architecture : Linear

Implementation Parameters

InputPipeline : 0
OutputPipeline : 0

See Also

“Set and View HDL Model and Block Parameters”

Introduced in R2010b

hdldispmdlparams

Display HDL model parameters with nondefault values

Syntax

```
hdldispmdlparams(model)
hdldispmdlparams(model, 'all')
```

Description

`hdldispmdlparams(model)` displays, for the specified model, the names and values of HDL parameters that have nondefault values.

`hdldispmdlparams(model, 'all')` displays the names and values of all HDL parameters for the specified model.

Input Arguments

model

Name of an open model.

Default: None

'all'

If you pass in 'all' , `hdldispmdlparams` displays the names and values of all HDL properties of the specified model.

Examples

The following example displays HDL properties of the current model that have nondefault values.

```
hdldispmdlparams(bdroot)

%%%%%%%%%%%%%%%%%%%%%%%%%%%%%%%%%%%%%%%%%%%%%%%%%%%%%%%%%%%%%%%%%%%%%%%%
HDL CodeGen Parameters (non-default)
%%%%%%%%%%%%%%%%%%%%%%%%%%%%%%%%%%%%%%%%%%%%%%%%%%%%%%%%%%%%%%%%%%%%%%%%

CodeGenerationOutput      : 'GenerateHDLCodeAndDisplayGeneratedModel'
HDLSubsystem              : 'simplevectorsum_2atomics/Subsystem'
OptimizationReport        : 'on'
ResetInputPort            : 'rst'
ResetType                  : 'Synchronous'
```

The following example displays HDL properties and values of the current model.

```
hdldispmdlparams(bdroot, 'all')

%%%%%%%%%%%%%%%%%%%%%%%%%%%%%%%%%%%%%%%%%%%%%%%%%%%%%%%%%%%%%%%%%%%%%%%%
HDL CodeGen Parameters
%%%%%%%%%%%%%%%%%%%%%%%%%%%%%%%%%%%%%%%%%%%%%%%%%%%%%%%%%%%%%%%%%%%%%%%%

AddPipelineRegisters      : 'off'
Backannotation            : 'on'
BlockGenerateLabel        : '_gen'
CheckHDL                  : 'off'
ClockEnableInputPort      : 'clk_enable'
```

```
.  
.  
VerilogFileExtension      : '.v'
```

See Also

“View HDL Model Parameters”

Introduced in R2010b

hdlget_param

Return value of specified HDL block-level parameter for specified block

Syntax

```
p = hdlget_param(block_path,prop)
```

Description

`p = hdlget_param(block_path,prop)` gets the value of a specified HDL property of a block or subsystem, and returns the value to the output variable.

Input Arguments

block_path

Path to a block or subsystem in the current model.

Default: None

prop

A character vector that designates one of the following:

- The name of an HDL block property of the block or subsystem specified by `block_path`.
- `'all'` : If `prop` is set to `'all'`, `hdlget_param` returns Name, Value pairs for HDL properties of the specified block.

Default: None

Output Arguments

p

`p` receives the value of the HDL block property specified by `prop`. The data type and dimensions of `p` depend on the data type and dimensions of the value returned. If `prop` is set to `'all'`, `p` is a cell array.

Examples

In the following example `hdlget_param` returns the value of the HDL block parameter `OutputPipeline` to the variable `p`.

```
p = hdlget_param(gcb,'OutputPipeline')  
p =  
    3
```

In the following example `hdlget_param` returns HDL block parameters and values for the current block to the cell array `p`.

```
p = hdlget_param(gcb, 'all')  
p =  
    'Architecture'    'Linear'    'InputPipeline'    [0]    'OutputPipeline'    [0]
```

Tips

- Use `hdlget_param` only to obtain the value of HDL block parameters (see “HDL Block Properties: General” for a list of block implementation parameters). Use `hdldispmdlparams` to see the values of HDL model parameters. To obtain the value of general model parameters, use the `get_param` function.

See Also

`hdlrestoreparams` | `hdlsaveparams` | `hdlset_param`

Introduced in R2010b

hdlLib

Display blocks that are compatible with HDL code generation

Syntax

```
hdlLib
hdlLib('off')
hdlLib('html')
hdlLib('librarymodel')
```

Description

`hdlLib` displays the blocks that are supported for HDL code generation, and for which you have a license, in the Library Browser. To build models that are compatible with the HDL Coder software, use blocks from this Library Browser view.

If you close and reopen the Library Browser in the same MATLAB session, the Library Browser continues to show only the blocks supported for HDL code generation. To show all blocks, regardless of HDL code generation compatibility, at the command prompt, enter `hdlLib('off')`.

`hdlLib('off')` displays all the blocks for which you have a license in the Library Browser, regardless of HDL code generation compatibility.

`hdlLib('html')` creates a library of blocks that are compatible with HDL code generation. It generates two additional HTML reports: a categorized list of blocks (`hdlblklist.html`) and a table of blocks and their HDL code generation parameters (`hdlsupported.html`).

To run `hdlLib('html')`, you must have an HDL Coder license.

`hdlLib('librarymodel')` displays blocks that are compatible with HDL code generation in the Library Browser. To build models that are compatible with the HDL Coder software, use blocks from this library.

The default library name is `hdlsupported`. After you generate the library, you can save it to a folder of your choice.

To keep the library current, you must regenerate it each time that you install a new software release.

To run `hdlLib('librarymodel')`, you must have an HDL Coder license.

Examples

Display Supported Blocks in the Library Browser

To display blocks that are compatible with HDL code generation in the Library Browser:

```
hdlLib
### Generating view of HDL Coder compatible blocks in Library Browser.
### To restore the Library Browser to the default Simulink view, enter "hdlLib off".
```

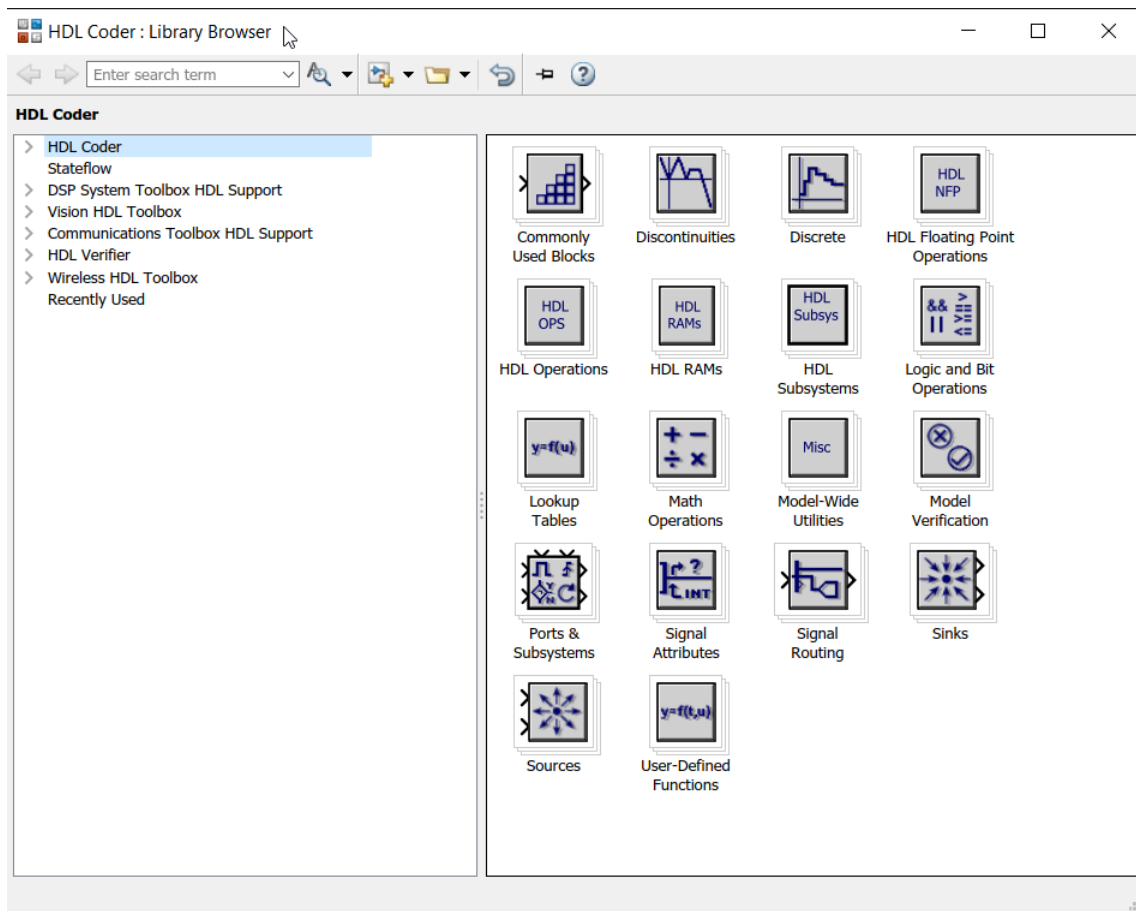

Display All Blocks in the Library Browser

To restore the Library Browser to the default view, in the Library Browser, click the  button. Alternatively, at the command line, enter:

```
hdllib('off')
```

```
### Restoring Library Browser to default view; removing the HDL Coder compatibility filter.
```

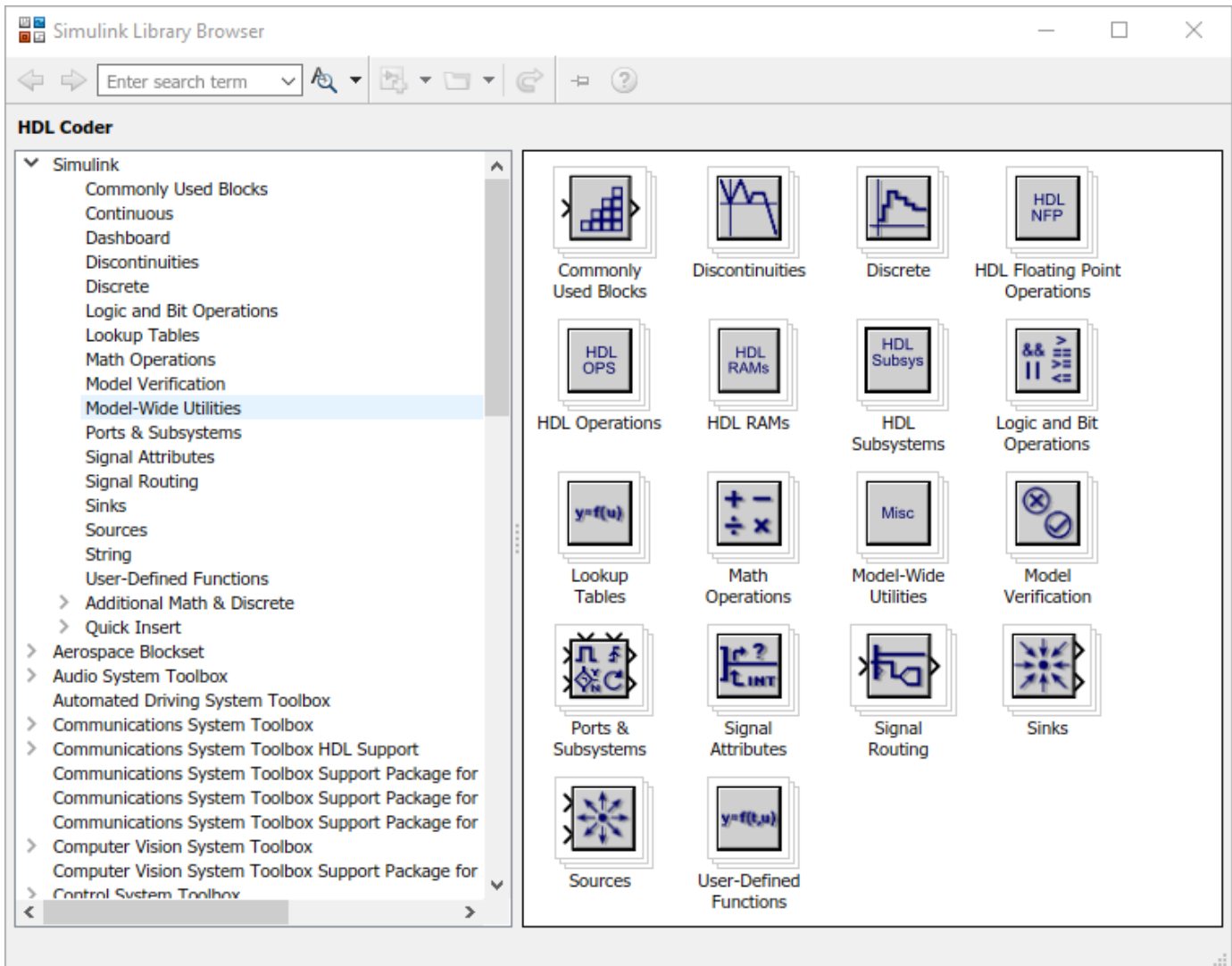

Create a Supported Blocks Library and HTML Reports

To create a library and HTML reports showing the blocks that are compatible with HDL code generation:

```
hdlLib('html')
```

```
### HDL supported block list hdlblklist.html
### HDL implementation list hdl-supported.html
```

The `hdl-supported` library opens. To view the reports, click the `hdlblklist.html` and `hdl-supported.html` links.

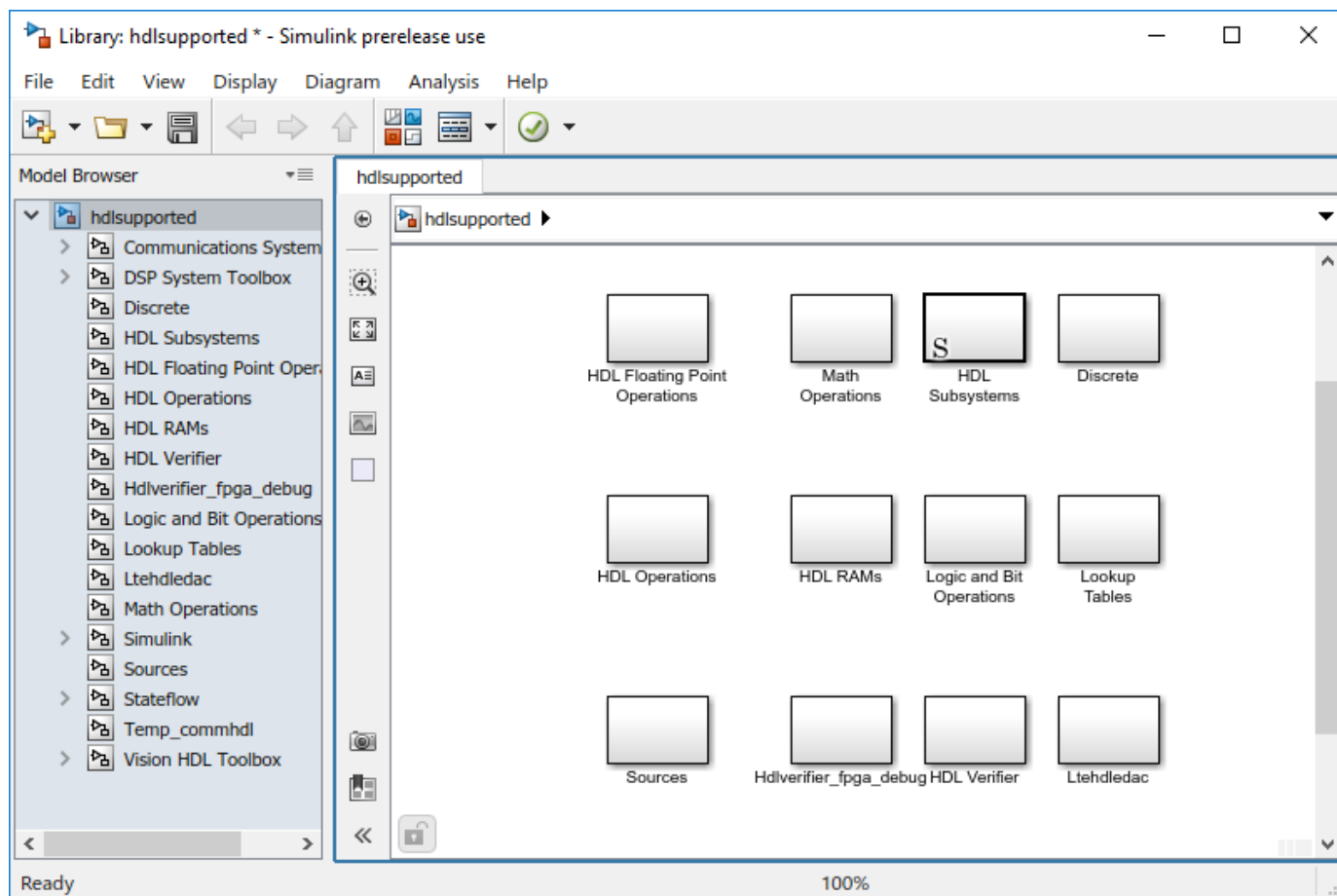

Create a Supported Blocks Library

To create a library that contains blocks that are compatible with HDL code generation:

```
hdllib('librarymodel')
```

The `hdl_supported` block library opens.

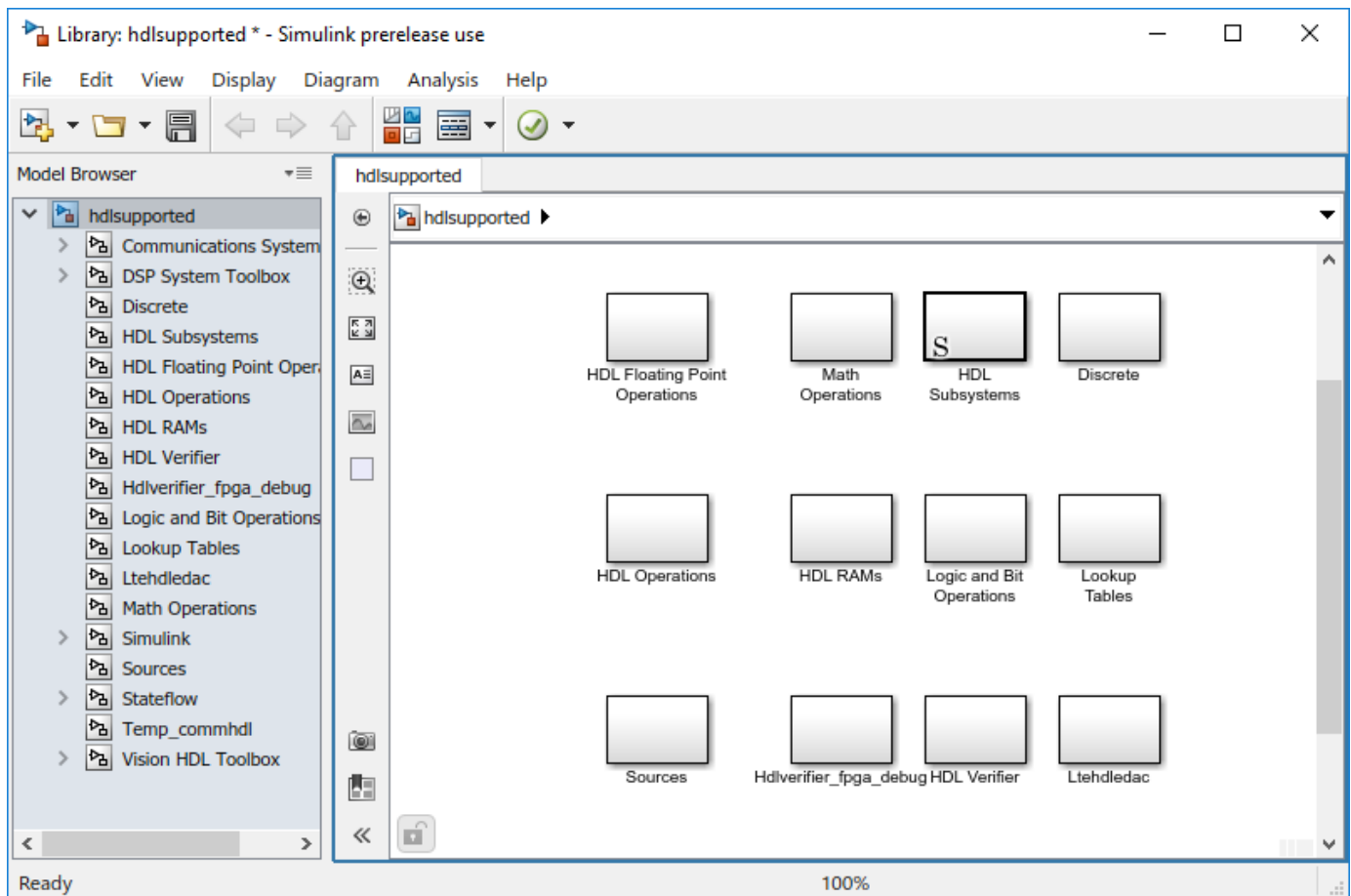

See Also

Topics

“Show Blocks Supported for HDL Code Generation”

“View HDL-Specific Block Documentation”

“Create Simulink Model for HDL Code Generation”

Introduced in R2006b

hdlcodeadvisor

Open HDL Code Advisor

Syntax

```
hdlcodeadvisor(subsystem)  
hdlcodeadvisor(model)
```

Description

`hdlcodeadvisor(subsystem)` opens the HDL Code Advisor for the subsystem within the model.

`hdlcodeadvisor(model)` opens the HDL Code Advisor for the model.

Examples

Open the HDL Code Advisor For a Model

This example shows how to open the HDL Code Advisor for the `sfir_single` model.

`sfir_single`

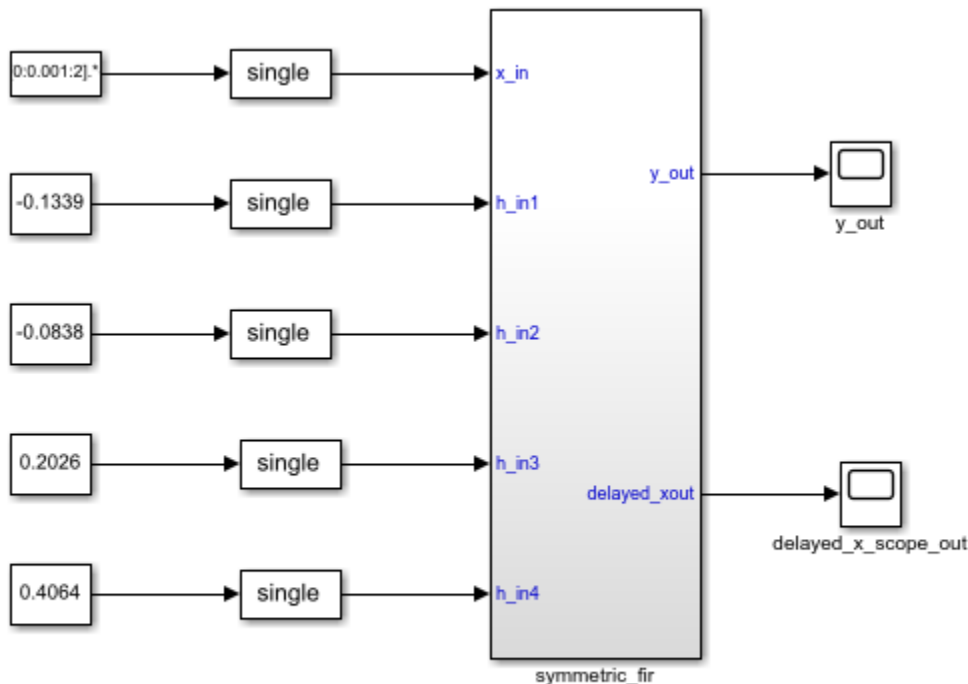

Copyright 2016-2017 The MathWorks, Inc.

To open the HDL Code Advisor for the `sfir_single` model, enter:

```
hdlcodeadvisor('sfir_single')
```

```
Updating Model Advisor cache...
```

```
Model Advisor cache updated. For new customizations, to update the cache, use the Advisor.Manage
```

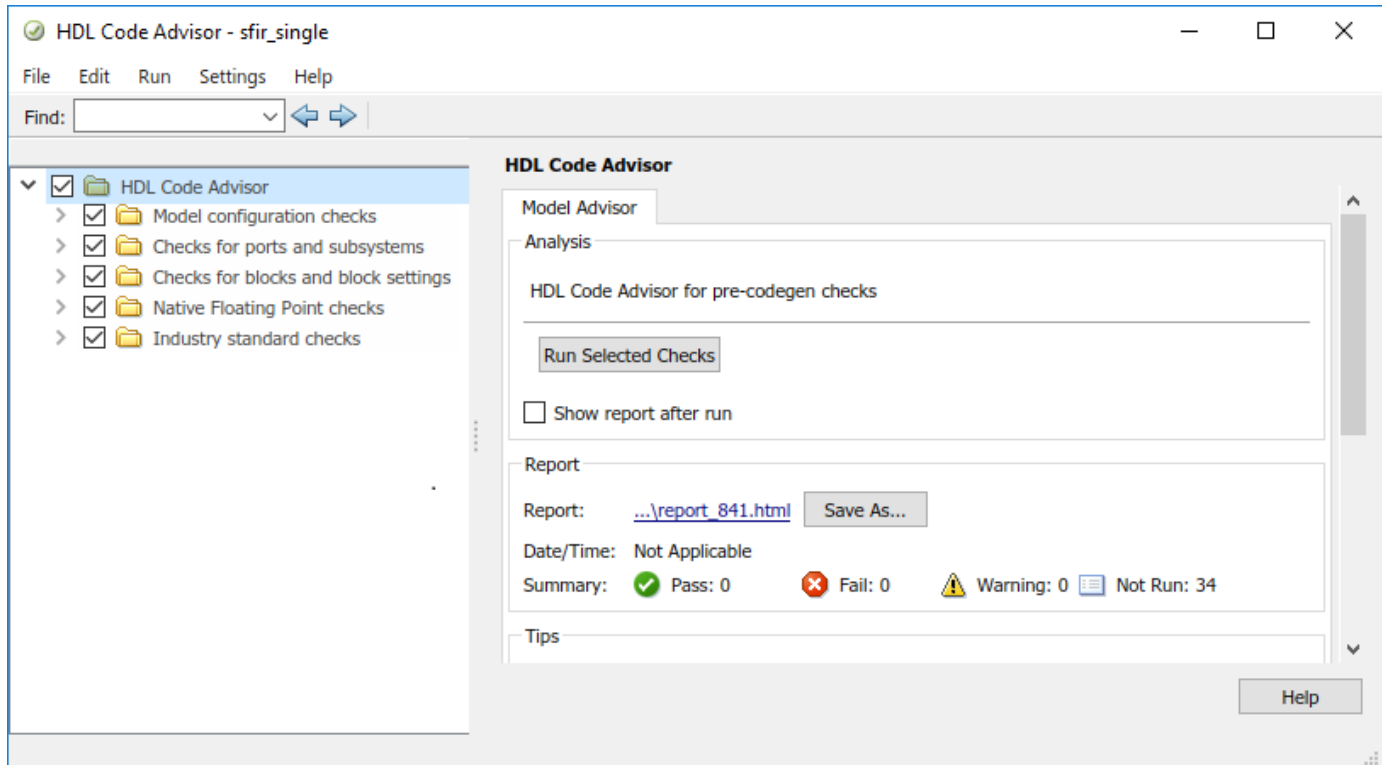

Open the HDL Model Checker For a Subsystem

This example shows how to open the HDL Model Checker for the `symmetric_fir` subsystem within the `sfir_single` model.

```
sfir_single
```

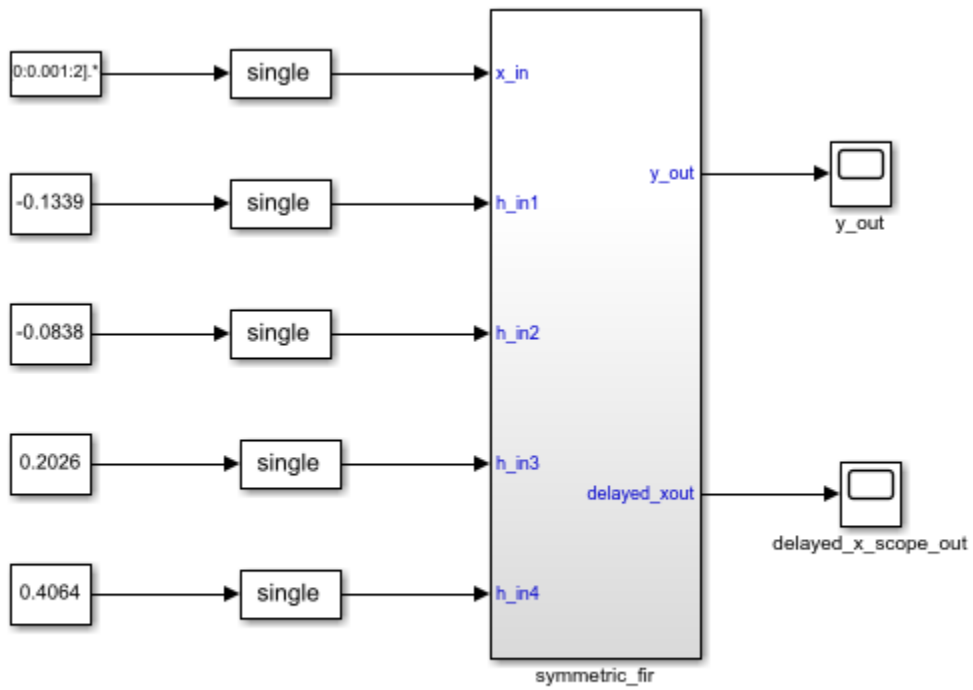

Copyright 2016-2017 The MathWorks, Inc.

To open the HDL Model Checker for the Symmetric fir subsystem, enter:

```
hdlcodeadvisor('sfir_single/symmetric_fir')
```

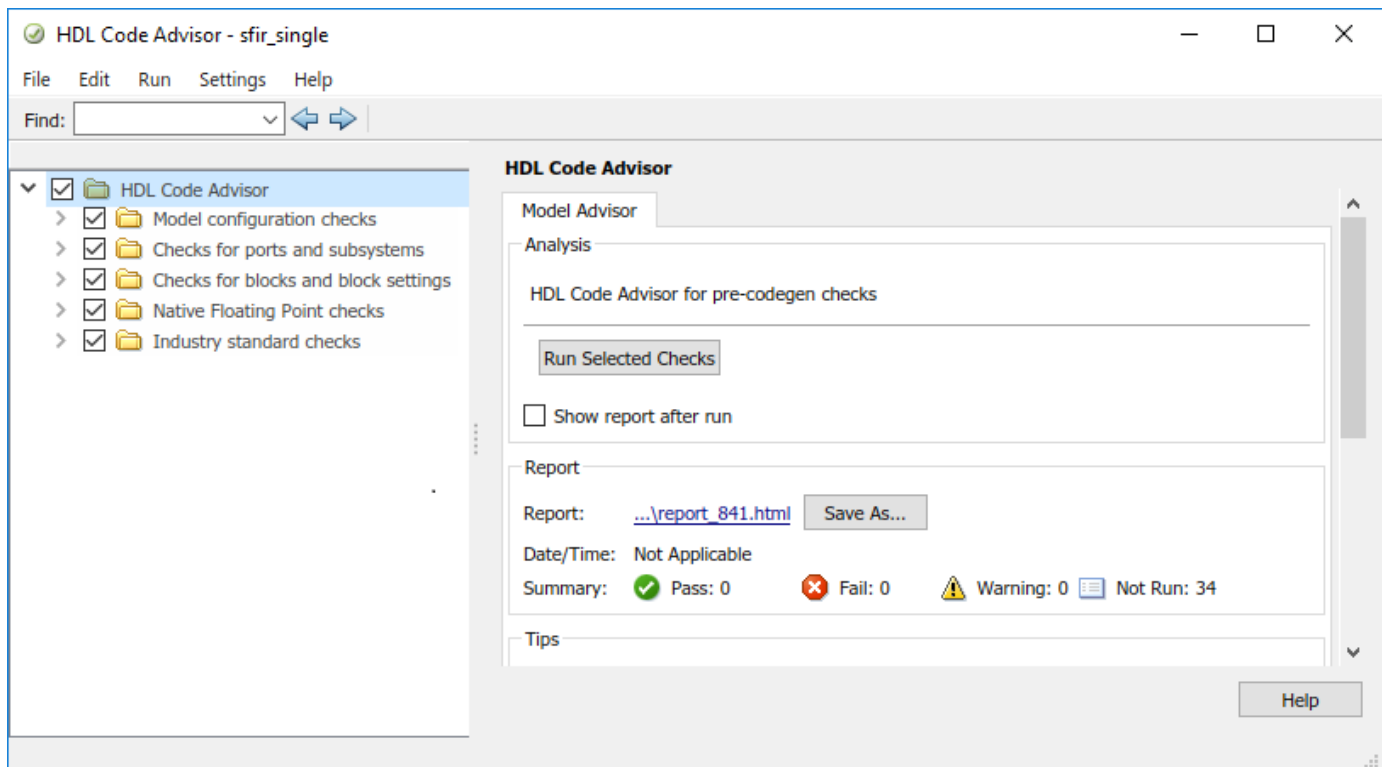

Input Arguments

subsystem – Subsystem name

character vector

Subsystem name or handle, specified as a character vector.

Data Types: char

model – Model name

character vector

Model name or handle, specified as a character vector.

Data Types: char

See Also

Topics

“Getting Started with the HDL Code Advisor”

“HDL Code Advisor Checks”

Introduced in R2017b

hdlrestoreparams

Restore block- and model-level HDL parameters to model

Syntax

```
hdlrestoreparams(dut)  
hdlrestoreparams(dut,filename)
```

Description

`hdlrestoreparams(dut)` restores to the specified model the default block- and model-level HDL settings.

`hdlrestoreparams(dut,filename)` restores to the specified model the block- and model-level HDL settings from a previously saved file.

Examples

Save and Restore HDL-Related Model Parameters

This example shows how to set HDL parameters on a model and save the parameters in a MATLAB® script.

Set Model HDL Parameters

Open the `sfir_fixed` model.

```
sfir_fixed
```

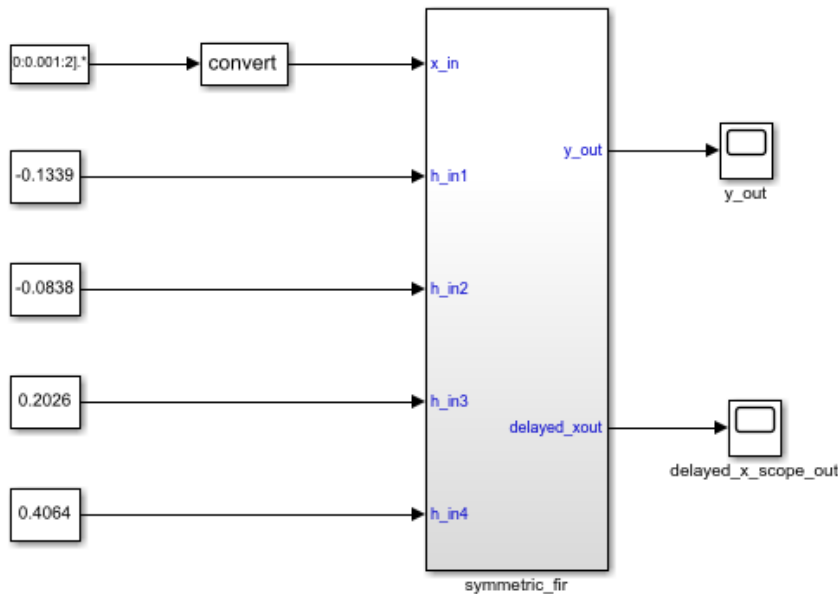

This example shows how to use HDL Coder to check, generate, and verify HDL for a fixed-point symmetric FIR filter. In MATLAB, type the following:
`checkhdl('sfir_fixed/symmetric_fir')`
`makehdl('sfir_fixed/symmetric_fir')`
`makehdltb('sfir_fixed/symmetric_fir')`
 Or double-click the blue button at the bottom to see the dialog.

Launch HDL Dialog

Run Demo

Copyright 2007 The MathWorks, Inc.

Verify that model parameters have default values.

```
hdlsaveparams('sfir_fixed/symmetric_fir')
```

```
%% Set Model 'sfir_fixed' HDL parameters
hdlset_param('sfir_fixed', 'HDLSubsystem', 'sfir_fixed/symmetric_fir');
```

Set HDL-related model parameters for the `symmetric_fir` subsystem.

```
hdlset_param('sfir_fixed/symmetric_fir', 'SharingFactor', 3)
hdlset_param('sfir_fixed/symmetric_fir', 'InputPipeline', 5)
```

Save Model HDL Parameters

Verify that model parameters are set.

```
hdlsaveparams('sfir_fixed/symmetric_fir')
```

```
%% Set Model 'sfir_fixed' HDL parameters
hdlset_param('sfir_fixed', 'HDLSubsystem', 'sfir_fixed/symmetric_fir');
```

```
% Set SubSystem HDL parameters
hdlset_param('sfir_fixed/symmetric_fir', 'InputPipeline', 5);
hdlset_param('sfir_fixed/symmetric_fir', 'SharingFactor', 3);
```

Save the model parameters to a MATLAB® script, `sfir_saved_params.m`.

```
hdlsaveparams('sfir_fixed/symmetric_fir', 'sfir_saved_params.m')
```

Verify Saved Parameters

Reset HDL-related model parameters to default values.

```
hdlrestoreparams('sfir_fixed/symmetric_fir')
```

Verify that model parameters have default values.

```
hdlsaveparams('sfir_fixed/symmetric_fir')
```

```
%% Set Model 'sfir_fixed' HDL parameters  
hdlset_param('sfir_fixed', 'HDLSubsystem', 'sfir_fixed');
```

Restore the saved model parameters from `sfir_saved_params.m`.

```
hdlrestoreparams('sfir_fixed/symmetric_fir', 'sfir_saved_params.m')
```

Verify that the saved model parameters are restored

```
hdlsaveparams('sfir_fixed/symmetric_fir')
```

```
%% Set Model 'sfir_fixed' HDL parameters  
hdlset_param('sfir_fixed', 'HDLSubsystem', 'sfir_fixed/symmetric_fir');
```

```
% Set SubSystem HDL parameters  
hdlset_param('sfir_fixed/symmetric_fir', 'InputPipeline', 5);  
hdlset_param('sfir_fixed/symmetric_fir', 'SharingFactor', 3);
```

Input Arguments

dut — DUT subsystem name

character vector

DUT subsystem name, specified as a character vector, with full hierarchical path.

Example: 'modelName/subsysTarget'

Example: 'modelName/subsysA/subsysB/subsysTarget'

filename — Name of file

character vector

Name of file containing previously saved HDL model parameters.

Example: 'mymodel_saved_params.m'

See Also

`hdlsaveparams`

Introduced in R2012b

hdlsaveparams

Save nondefault block- and model-level HDL parameters

Syntax

```
hdlsaveparams(dut)
hdlsaveparams(dut,filename)
hdlsaveparams(dut,filename,force_overwrite)
varname = hdlsaveparams(dut)
```

Description

`hdlsaveparams(dut)` displays nondefault block- and model-level HDL parameters.

`hdlsaveparams(dut,filename)` saves nondefault block- and model-level HDL parameters to a MATLAB script.

`hdlsaveparams(dut,filename,force_overwrite)` saves nondefault block- and model-level HDL parameters to a MATLAB script and specifies whether to overwrite the previously saved parameters MATLAB script.

`varname = hdlsaveparams(dut)` saves the nondefault block- and model-level HDL parameters to a structure array, `varname`.

Examples

Display HDL-Related Nondefault Model Parameters

Open the model.

```
sfir_fixed
```

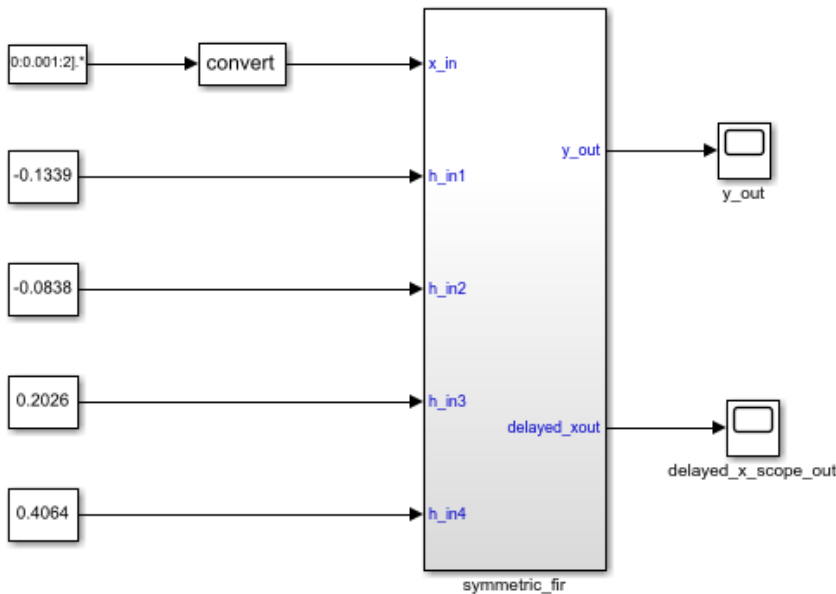

This example shows how to use HDL Coder to check, generate, and verify HDL for a fixed-point symmetric FIR filter. In MATLAB, type the following:
`checkhdl('sfir_fixed/symmetric_fir')`
`makehdl('sfir_fixed/symmetric_fir')`
`makehdltb('sfir_fixed/symmetric_fir')`
 Or double-click the blue button at the bottom to see the dialog.

Launch HDL Dialog

Run Demo

Copyright 2007 The MathWorks, Inc.

Set HDL-related model parameters for the `symmetric_fir` subsystem.

```
hdlset_param('sfir_fixed/symmetric_fir', 'SharingFactor', 3)
hdlset_param('sfir_fixed/symmetric_fir', 'InputPipeline', 5)
```

Display HDL-related nondefault model parameters for the `symmetric_fir` subsystem.

```
hdlsaveparams('sfir_fixed/symmetric_fir')

%% Set Model 'sfir_fixed' HDL parameters
hdlset_param('sfir_fixed', 'HDLSubsystem', 'sfir_fixed/symmetric_fir');

% Set SubSystem HDL parameters
hdlset_param('sfir_fixed/symmetric_fir', 'InputPipeline', 5);
hdlset_param('sfir_fixed/symmetric_fir', 'SharingFactor', 3);
```

The output identifies the subsystem and displays its HDL-related parameter values.

Save and Restore HDL-Related Model Parameters

This example shows how to set HDL parameters on a model and save the parameters in a MATLAB® script.

Set Model HDL Parameters

Open the `sfir_fixed` model.

`sfir_fixed`

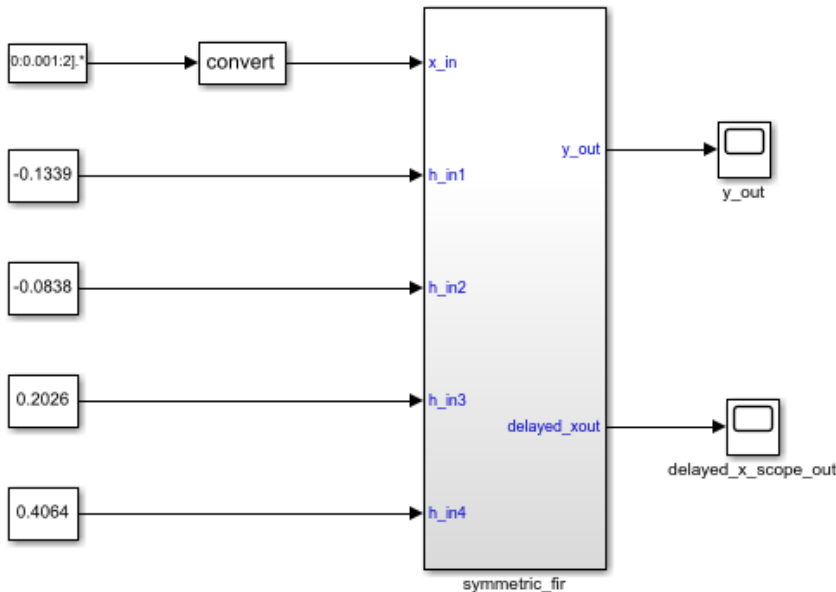

This example shows how to use HDL Coder to check, generate, and verify HDL for a fixed-point symmetric FIR filter. In MATLAB, type the following:

```
checkhdl('sfir_fixed/symmetric_fir')
makehdl('sfir_fixed/symmetric_fir')
makehdltb('sfir_fixed/symmetric_fir')
```

Or double-click the blue button at the bottom to see the dialog.

Launch HDL Dialog

Run Demo

Copyright 2007 The MathWorks, Inc.

Verify that model parameters have default values.

```
hdlsaveparams('sfir_fixed/symmetric_fir')
```

```
%% Set Model 'sfir_fixed' HDL parameters
hdlset_param('sfir_fixed', 'HDLSubsystem', 'sfir_fixed/symmetric_fir');
```

Set HDL-related model parameters for the `symmetric_fir` subsystem.

```
hdlset_param('sfir_fixed/symmetric_fir', 'SharingFactor', 3)
hdlset_param('sfir_fixed/symmetric_fir', 'InputPipeline', 5)
```

Save Model HDL Parameters

Verify that model parameters are set.

```
hdlsaveparams('sfir_fixed/symmetric_fir')
```

```
%% Set Model 'sfir_fixed' HDL parameters
hdlset_param('sfir_fixed', 'HDLSubsystem', 'sfir_fixed/symmetric_fir');
```

```
% Set SubSystem HDL parameters
hdlset_param('sfir_fixed/symmetric_fir', 'InputPipeline', 5);
hdlset_param('sfir_fixed/symmetric_fir', 'SharingFactor', 3);
```

Save the model parameters to a MATLAB® script, `sfir_saved_params.m`.

```
hdlsaveparams('sfir_fixed/symmetric_fir', 'sfir_saved_params.m')
```

Verify Saved Parameters

Reset HDL-related model parameters to default values.

```
hdlrestoreparams('sfir_fixed/symmetric_fir')
```

Verify that model parameters have default values.

```
hdlsaveparams('sfir_fixed/symmetric_fir')
```

```
%% Set Model 'sfir_fixed' HDL parameters
hdlset_param('sfir_fixed', 'HDLSubsystem', 'sfir_fixed');
```

Restore the saved model parameters from `sfir_saved_params.m`.

```
hdlrestoreparams('sfir_fixed/symmetric_fir', 'sfir_saved_params.m')
```

Verify that the saved model parameters are restored

```
hdlsaveparams('sfir_fixed/symmetric_fir')
```

```
%% Set Model 'sfir_fixed' HDL parameters
hdlset_param('sfir_fixed', 'HDLSubsystem', 'sfir_fixed/symmetric_fir');
```

```
% Set SubSystem HDL parameters
hdlset_param('sfir_fixed/symmetric_fir', 'InputPipeline', 5);
hdlset_param('sfir_fixed/symmetric_fir', 'SharingFactor', 3);
```

Overwrite Previously Saved HDL Parameters File

This example shows how to set HDL parameters on a model, save the parameters in a MATLAB® script, and then overwrite the saved parameters.

Set Model HDL Parameters

Open the `sfir_fixed` model.

```
sfir_fixed
```

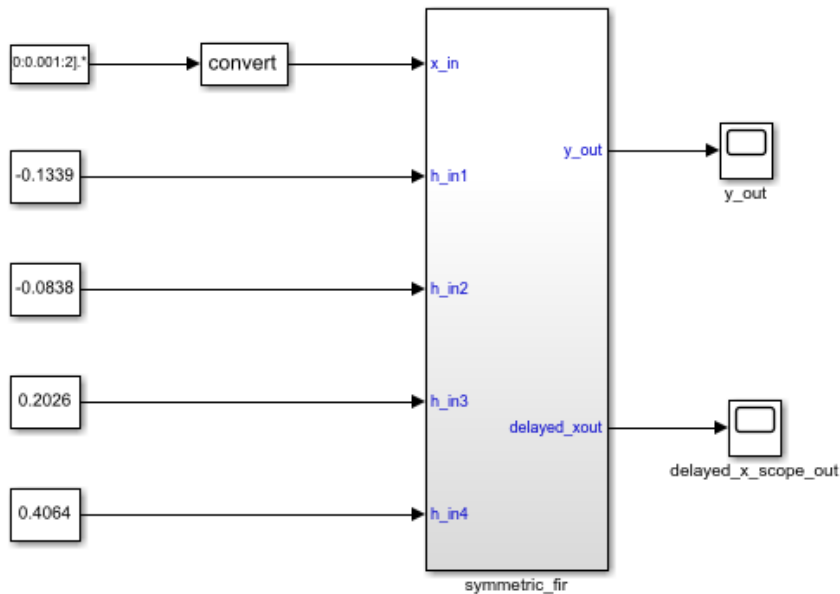

This example shows how to use HDL Coder to check, generate, and verify HDL for a fixed-point symmetric FIR filter. In MATLAB, type the following:
`checkhdl('sfir_fixed/symmetric_fir')`
`makehdl('sfir_fixed/symmetric_fir')`
`makehdltb('sfir_fixed/symmetric_fir')`
 Or double-click the blue button at the bottom to see the dialog.

Launch HDL Dialog

Run Demo

Copyright 2007 The MathWorks, Inc.

Verify that model parameters have default values.

```
hdlsaveparams('sfir_fixed/symmetric_fir')
```

```
%% Set Model 'sfir_fixed' HDL parameters
hdlset_param('sfir_fixed', 'HDLSubsystem', 'sfir_fixed/symmetric_fir');
```

Set HDL-related model parameters for the `symmetric_fir` subsystem.

```
hdlset_param('sfir_fixed/symmetric_fir', 'SharingFactor', 3)
hdlset_param('sfir_fixed/symmetric_fir', 'InputPipeline', 5)
```

Save Model HDL Parameters

Verify that model parameters are set.

```
hdlsaveparams('sfir_fixed/symmetric_fir')
```

```
%% Set Model 'sfir_fixed' HDL parameters
hdlset_param('sfir_fixed', 'HDLSubsystem', 'sfir_fixed/symmetric_fir');
```

```
% Set SubSystem HDL parameters
hdlset_param('sfir_fixed/symmetric_fir', 'InputPipeline', 5);
hdlset_param('sfir_fixed/symmetric_fir', 'SharingFactor', 3);
```

Save the model parameters to a MATLAB® script, `sfir_saved_params.m`.

```
hdlsaveparams('sfir_fixed/symmetric_fir', 'sfir_saved_params.m')
```

Verify Saved Parameters

Reset HDL-related model parameters to default values.

```
hdlrestoreparams('sfir_fixed/symmetric_fir')
```

Verify that model parameters have default values.

```
hdlsaveparams('sfir_fixed/symmetric_fir')
```

```
%% Set Model 'sfir_fixed' HDL parameters
hdlset_param('sfir_fixed', 'HDLSubsystem', 'sfir_fixed');
```

Restore the saved model parameters from `sfir_saved_params.m`.

```
hdlrestoreparams('sfir_fixed/symmetric_fir', 'sfir_saved_params.m')
```

Verify that the saved model parameters are restored

```
hdlsaveparams('sfir_fixed/symmetric_fir')
```

```
%% Set Model 'sfir_fixed' HDL parameters
hdlset_param('sfir_fixed', 'HDLSubsystem', 'sfir_fixed/symmetric_fir');
```

```
% Set SubSystem HDL parameters
hdlset_param('sfir_fixed/symmetric_fir', 'InputPipeline', 5);
hdlset_param('sfir_fixed/symmetric_fir', 'SharingFactor', 3);
```

Modify Saved HDL Parameters

Modify HDL-related model parameters set for the `symmetric_fir` subsystem.

```
hdlset_param('sfir_fixed/symmetric_fir', 'SharingFactor', 4)
hdlset_param('sfir_fixed/symmetric_fir', 'OutputPipeline', 2)
hdlset_param('sfir_fixed', 'ShareAdders', 'on')
```

Overwrite Saved Parameters File

Set the `force_overwrite` flag to `true` to overwrite the parameters file `sfir_saved_parameters.m` with the new parameters. If you do not specify this flag, HDL Coder™ generates an error and doesn't overwrite the parameter values. When you run `hdlsaveparams` with the parameter set to `true`, HDL Coder™ generates a warning that it overwrites the file.

```
hdlsaveparams('sfir_fixed/symmetric_fir', 'sfir_saved_params.m', 'true')
```

```
Warning: HDL parameters file 'sfir_saved_params.m' already exists. By
overwriting it now, you will lose any parameter settings made earlier.
```

Verify Resaved Parameters

Reset HDL-related model parameters to default values.

```
hdlrestoreparams('sfir_fixed/symmetric_fir')
```

Verify that model parameters have default values.

```
hdlsaveparams('sfir_fixed/symmetric_fir')
```

```
%% Set Model 'sfir_fixed' HDL parameters
hdlset_param('sfir_fixed', 'HDLSubsystem', 'sfir_fixed');
```

Restore the saved model parameters from `sfir_saved_params.m`.

```
hdlrestoreparams('sfir_fixed/symmetric_fir', 'sfir_saved_params.m')
```

Verify that the saved model parameters are restored

```
hdlsaveparams('sfir_fixed/symmetric_fir')
```

```
%% Set Model 'sfir_fixed' HDL parameters
hdlset_param('sfir_fixed', 'HDLSubsystem', 'sfir_fixed/symmetric_fir');
hdlset_param('sfir_fixed', 'ShareAdders', 'on');
```

```
% Set SubSystem HDL parameters
hdlset_param('sfir_fixed/symmetric_fir', 'InputPipeline', 5);
hdlset_param('sfir_fixed/symmetric_fir', 'OutputPipeline', 2);
hdlset_param('sfir_fixed/symmetric_fir', 'SharingFactor', 4);
```

Save and Access Non-Default HDL Parameters in a Structure Array

This example shows how to save non-default HDL model and block parameters in a structure array and access individual parameters.

Open the model

```
sfir_single
sim('sfir_single')
```

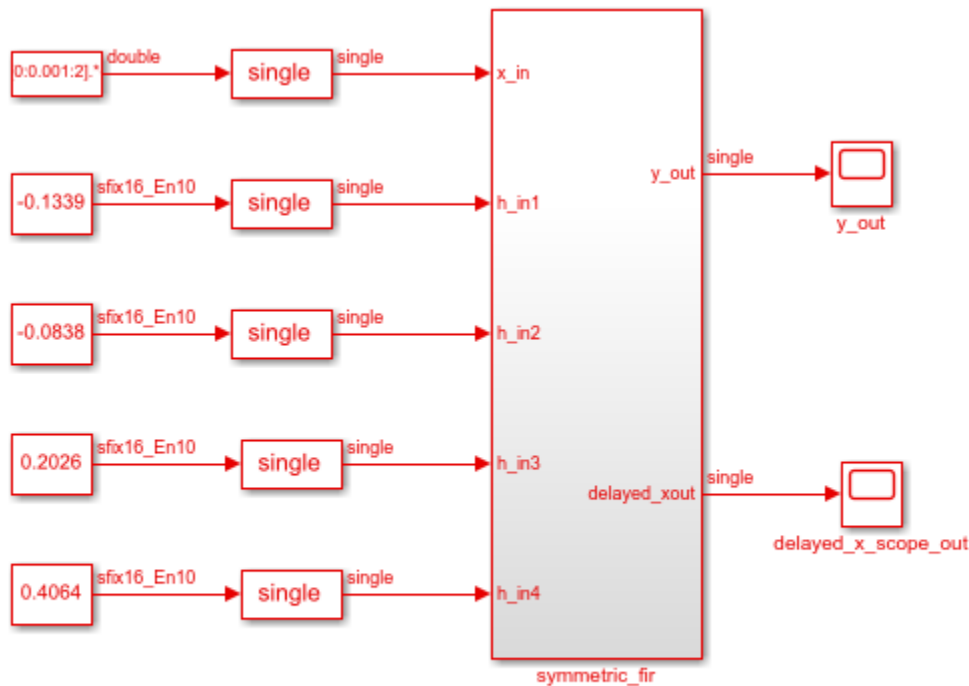

Copyright 2016-2017 The MathWorks, Inc.

Save HDL Model and Block parameters

```
hparams = hdlsaveparams('sfir_single/symmetric_fir');
```

```
% Set Model 'sfir_single' HDL parameters
hdlset_param('sfir_single', 'FloatingPointTargetConfiguration', hdlcoder.createFloatingPointTargetConfiguration(
, 'MantissaMultiplyStrategy', 'FullMultiplier') ...
);
hdlset_param('sfir_single', 'HDLSubsystem', 'sfir_single/symmetric_fir');
```

```
% Set SubSystem HDL parameters
hdlset_param('sfir_single/symmetric_fir', 'InputPipeline', 1);
hdlset_param('sfir_single/symmetric_fir', 'OutputPipeline', 1);
```

View and Access Block Parameters

```
hparams
```

```
hparams =
```

```
1x4 struct array with fields:
```

```
object
parameter
value
```

To see specific non-default parameters saved in the structure, you can access individual elements of the structure.

```
hparams(2)
```

```
ans =
```

```
struct with fields:
    object: 'sfir_single'
    parameter: 'HDLSubsystem'
    value: 'sfir_single/symmetric_fir'
```

To view the parameters and values specified for the model, in the MATLAB™ Workspace, double-click the `hparams` variable. You see the fields of the structure array and the corresponding values in the MATLAB Editor.

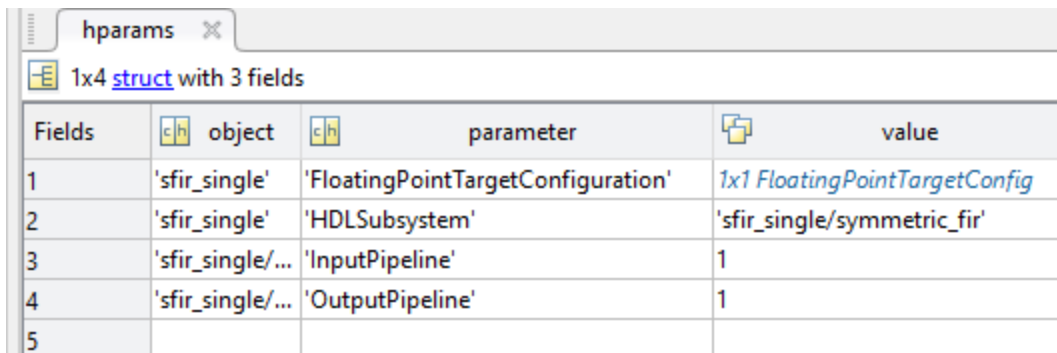

Fields	object	parameter	value
1	'sfir_single'	'FloatingPointTargetConfiguration'	1x1 FloatingPointTargetConfig
2	'sfir_single'	'HDLSubsystem'	'sfir_single/symmetric_fir'
3	'sfir_single/...'	'InputPipeline'	1
4	'sfir_single/...'	'OutputPipeline'	1
5			

Input Arguments

dut — DUT subsystem name

character vector

DUT subsystem name, specified as a character vector, with full hierarchical path.

Example: 'modelName/subsysTarget'

Example: 'modelName/subsysA/subsysB/subsysTarget'

filename — Name of file

character vector

Name of file to which you are saving model parameters, specified as a character vector.

Example: 'mymodel_saved_params.m'

force_overwrite — Overwrite parameters file

boolean

Specify whether to overwrite the previously saved parameters file as a boolean.

Example: 'true'

Output Arguments

varname — Name of variable containing saved parameters

struct

Specify the name of the variable that contains the saved model parameters. The variable are saved as a structure array.

Example: 'hparams'

See Also

hdlrestoreparams

Introduced in R2012b

hdlset_param

Set HDL-related parameters at model or block level

Syntax

```
hdlset_param(path,Name,Value)
```

Description

`hdlset_param(path,Name,Value)` sets HDL-related parameters in the block or model referenced by `path`. The parameters to be set, and their values, are specified by one or more `Name,Value` pair arguments. You can specify several name and value pair arguments in any order as `Name1,Value1, ...,NameN,ValueN`.

Input Arguments

path

Path to the model or block for which `hdlset_param` is to set one or more parameter values.

Default: None

Name-Value Pair Arguments

Specify optional comma-separated pairs of `Name,Value` arguments, where `Name` is the argument name and `Value` is the corresponding value. `Name` must appear inside single quotes (' '). You can specify several name and value pair arguments in any order as `Name1,Value1, ...,NameN,ValueN`.

Name

`Name` is a character vector that specifies one of the following:

- A model-level HDL-related property. See [Properties — Alphabetical List](#) for a list of model-level properties, their data types and their default values.
- An HDL block property, such as an implementation name or an implementation parameter. See “HDL Block Properties: General” for a list of block implementation parameters.

Default: None

Value

`Value` is a value to be applied to the corresponding property in a `Name,Value` argument.

Default: Default value is dependent on the property.

Examples

The following example uses the `sfir_fixed` model to demonstrate how to locate a group of blocks in a subsystem and specify the same output pipeline depth for each of the blocks.

```
open sfir_fixed;
prodblocks = find_system('sfir_fixed/symmetric_fir', 'BlockType', 'Product');
for ii=1:length(prodblocks), hdlset_param(prodblocks{ii}, 'OutputPipeline', 2), end;
```

Tips

- When you set multiple parameters on the same model or block, use a single `hdlset_param` command with multiple pairs of arguments, rather than multiple `hdlset_param` commands. This technique is more efficient because using a single call requires evaluating parameters only once.
- To set HDL block parameters for multiple blocks, use the `find_system` function to locate the blocks of interest. Then, use a loop to iterate over the blocks and call `hdlset_param` to set the desired parameters.

See Also

`hdlget_param` | `hdlrestoreparams` | `hdlsaveparams`

Topics

“Set and View HDL Model and Block Parameters”

“Set HDL Block Parameters for Multiple Blocks Programmatically”

Introduced in R2010b

hdlsetup

Set up model parameters for HDL code generation

Syntax

```
hdlsetup('modelName')
```

Description

`hdlsetup('modelName')` sets the parameters of the model specified by *modelName* to common default values for HDL code generation.

Open the model before you invoke the `hdlsetup` command. After using `hdlsetup`, you can use `set_param` to modify these default settings. For example:

```
set_param(gcs, 'Solver', 'VariableStepDiscrete')
```

See this table for the solver configuration parameters that `hdlsetup` configures. These parameters reside in the **Solver** pane of the Configuration Parameters dialog box.

Configuration Parameter Setting	Command-line Parameter Setting	Description
Set Type to Fixed-step and Solver to Discrete (no continuous states).	Set Solver to FixedStepDiscrete.	This fixed-step solver is best suited for simulating discrete systems. Variable-step solvers are supported under limited conditions.
Set Fixed-step size (fundamental sample time) to auto.	Set FixedStep to auto.	If Fixed step size is set to auto the step size is chosen automatically, based on the sample times specified in the model.
Disable the Treat each discrete rate as a separate task check box.	Set EnableMultiTasking to off.	HDL Coder does not currently support models that execute in multitasking mode..

`hdlsetup` also configures other parameters that control error severity levels, data logging, and model display options. To view the complete set of model parameters affected by `hdlsetup`, see “Check for safe model parameters”.

Introduced in R2006b

hdlsetuptoolpath

Set up system environment to access FPGA synthesis software

Syntax

```
hdlsetuptoolpath('ToolName', TOOLNAME, 'ToolPath', TOOLPATH)
```

Description

`hdlsetuptoolpath('ToolName', TOOLNAME, 'ToolPath', TOOLPATH)` adds a third-party FPGA synthesis tool to your system path. It sets up the system environment variables for the synthesis tool. To configure one or more supported third-party FPGA synthesis tools to use with HDL Coder, use the `hdlsetuptoolpath` function.

Before opening the HDL Workflow Advisor, add the tool to your system path. If you already have the HDL Workflow Advisor open, see “Add Synthesis Tool for Current HDL Workflow Advisor Session”.

Examples

Set Up Intel Quartus Prime

The following command sets the synthesis tool path to point to an installed Intel® Quartus® Prime Standard Edition 18.1 executable file. You must have already installed Altera Quartus II.

```
hdlsetuptoolpath('ToolName', 'Altera Quartus II', 'ToolPath', ...  
'C:\intel\18.1\quartus\bin\quartus.exe');
```

Set Up Intel Quartus Pro

The following command sets the synthesis tool path to point to an installed Intel Quartus Pro 19.2 executable file. You must have already installed Intel Quartus Pro.

```
hdlsetuptoolpath('ToolName', 'Intel Quartus Pro', 'ToolPath', ...  
'C:\intel\19.2_pro\quartus\bin64\qpro.exe');
```

Note An installation of Quartus Pro contains both `quartus.exe` and `qpro.exe` executable files. When both tools are added to the path by using `hdlsetuptoolpath`, HDL Coder checks the tool availability before running the HDL Workflow Advisor.

Set Up Xilinx ISE

The following command sets the synthesis tool path to point to an installed Xilinx ISE 14.7 executable file. You must have already installed Xilinx ISE.

```
hdlsetuptoolpath('ToolName', 'Xilinx ISE', 'ToolPath', ...  
'C:\Xilinx\14.7\ISE_DS\ISE\bin\nt64\ise.exe');
```

Set Up Xilinx Vivado

The following command sets the synthesis tool path to point to an installed Vivado® Design Suite 2019.1 batch file. You must have already installed Xilinx Vivado.

```
hdlsetuptoolpath('ToolName','Xilinx Vivado','ToolPath',...
    'C:\Xilinx\Vivado\2019.1\bin\vivado.bat');
```

Set Up Microsemi Libero SoC

The following command sets the synthesis tool path to point to an installed Microsemi® Libero® Design Suite batch file. You must have already installed Microsemi Libero SoC.

```
hdlsetuptoolpath('ToolName','Microsemi Libero SoC','ToolPath',...
    'C:\Microsemi\Libero_SoC_v11.8\Designer\bin\libero.exe');
```

Input Arguments

TOOLNAME — Synthesis tool name

character vector

Synthesis tool name, specified as a character vector.

Example: 'Xilinx Vivado'

TOOLPATH — Full path to the synthesis tool executable or batch file

character vector

Full path to the synthesis tool executable or batch file, specified as a character vector.

Example: 'C:\Xilinx\Vivado\2018.3\bin\vivado.bat'

Tips

- If you have an icon for the tool on your Windows® desktop, you can find the full path to the synthesis tool.
 - 1 Right-click the icon and select **Properties**.
 - 2 Click the **Shortcut** tab.
- The `hdlsetuptoolpath` function changes the system path and system environment variables for only the current MATLAB session. To execute `hdlsetuptoolpath` programmatically when MATLAB starts, add `hdlsetuptoolpath` to your `startup.m` script.

See Also

`setenv` | `startup`

Topics

“HDL Language Support and Supported Third-Party Tools and Hardware”

“Tool Setup”

“Add Synthesis Tool for Current HDL Workflow Advisor Session”

Introduced in R2011a

makehdl

Generate HDL RTL code from model, subsystem, or model reference

Syntax

```
makehdl(dut)  
makehdl(dut, Name, Value)
```

Description

makehdl(dut) generates HDL code from the specified DUT model, subsystem, or model reference.

Note Running this command can activate the **Open at simulation start** setting for blocks such as the Scope block and therefore invoke the block.

makehdl(dut, Name, Value) generates HDL code from the specified DUT model, subsystem, or model reference with options specified by one or more name-value pair arguments.

Examples

Generate VHDL for the Current Model

This example shows how to generate VHDL for the symmetric FIR model.

Open the `sfir_fixed` model.

```
sfir_fixed
```

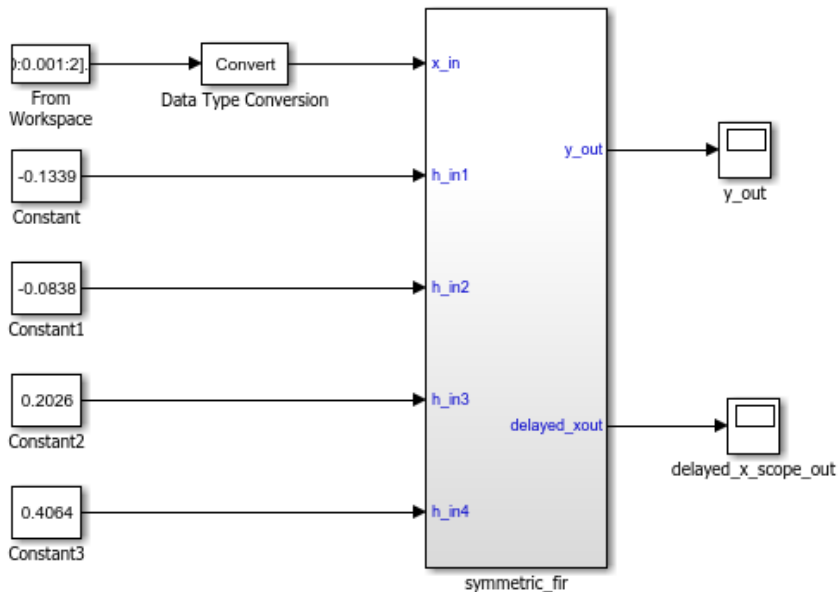

This example shows how to use HDL Coder to check, generate, and verify HDL for a fixed-point symmetric FIR filter. In MATLAB, type the following:

```
checkhdl('sfir_fixed/symmetric_fir')
makehdl('sfir_fixed/symmetric_fir')
makehdltb('sfir_fixed/symmetric_fir')
```

Or double-click the blue button at the bottom to see the dialog.

Launch HDL Dialog

Run Demo

Copyright 2007 The MathWorks, Inc.

Generate HDL code for the current model with code generation options set to default values.

```
makehdl('sfir_fixed/symmetric_fir','TargetDirectory','C:\GenVHDL\hdlsrc')
```

```
### Generating HDL for 'sfir_fixed/symmetric_fir'.
### Starting HDL check.
### Begin VHDL Code Generation for 'sfir_fixed'.
### Working on sfir_fixed/symmetric_fir as C:\GenVHDL\hdlsrc\sfir_fixed\symmetric_fir.vhd.
### Creating HDL Code Generation Check Report file://C:\GenVHDL\hdlsrc\sfir_fixed\symmetric_fir_
### HDL check for 'sfir_fixed' complete with 0 errors, 0 warnings, and 0 messages.
### HDL code generation complete.
```

The generated VHDL code is saved in the hdlsrc folder.

Generate Verilog for a Subsystem Within a Model

Generate Verilog® for the subsystem symmetric_fir within the model sfir_fixed.

Open the sfir_fixed model.

```
sfir_fixed;
```

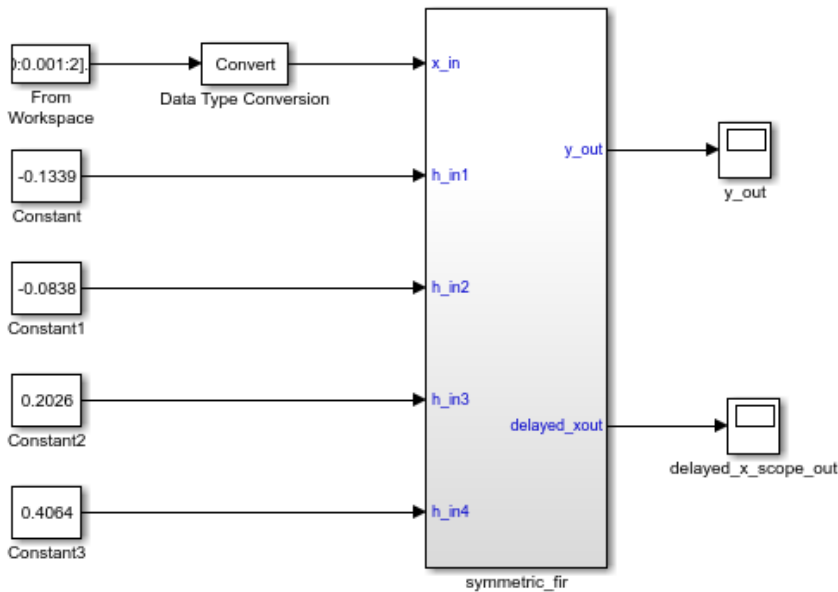

This example shows how to use HDL Coder to check, generate, and verify HDL for a fixed-point symmetric FIR filter. In MATLAB, type the following:
`checkhdl('sfir_fixed/symmetric_fir')`
`makehdl('sfir_fixed/symmetric_fir')`
`makehdltb('sfir_fixed/symmetric_fir')`
 Or double-click the blue button at the bottom to see the dialog.

Launch HDL Dialog

Run Demo
 Copyright 2007 The MathWorks, Inc.

The model opens in a new Simulink® window.

Generate Verilog for the `symmetric_fir` subsystem.

```
makehdl('sfir_fixed/symmetric_fir', 'TargetLanguage', 'Verilog', ...
        'TargetDirectory', 'C:/Generate_Verilog/hdlsrc')
```

```
### Generating HDL for 'sfir_fixed/symmetric_fir'.
### Starting HDL check.
### Begin Verilog Code Generation for 'sfir_fixed'.
### Working on sfir_fixed/symmetric_fir as C:\Generate_Verilog\hdlsrc\sfir_fixed\symmetric_fir.v
### Creating HDL Code Generation Check Report file://C:\Generate_Verilog\hdlsrc\sfir_fixed\symme
### HDL check for 'sfir_fixed' complete with 0 errors, 0 warnings, and 0 messages.
### HDL code generation complete.
```

The generated Verilog code for the `symmetric_fir` subsystem is saved in `hdlsrc\sfir_fixed\symmetric_fir.v`.

Close the model.

```
bdclose('sfir_fixed');
```

Check Subsystem for Compatibility with HDL Code Generation

Check that the subsystem `symmetric_fir` is compatible with HDL code generation, then generate HDL.

Open the `sfir_fixed` model.

`sfir_fixed`

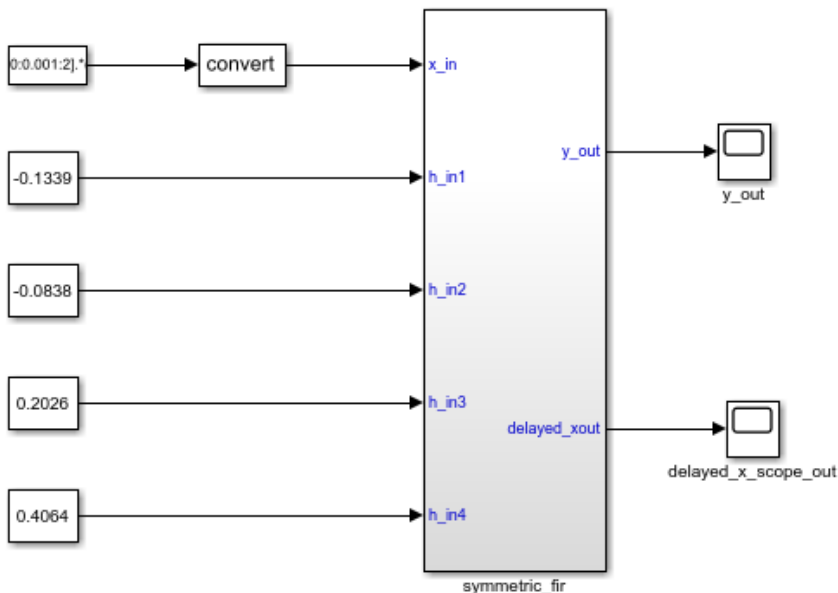

This example shows how to use HDL Coder to check, generate, and verify HDL for a fixed-point symmetric FIR filter. In MATLAB, type the following:

```
checkhdl('sfir_fixed/symmetric_fir')
makehdl('sfir_fixed/symmetric_fir')
makehdltb('sfir_fixed/symmetric_fir')
```

Or double-click the blue button at the bottom to see the dialog.

Launch HDL Dialog

Run Demo

Copyright 2007 The MathWorks, Inc.

The model opens in a new Simulink® window.

Use the `checkhdl` function to check whether the `symmetric_fir` subsystem is compatible with HDL code generation.

```
hdlset_param('sfir_fixed', 'TargetDirectory', 'C:/HDL_Checks/hdlsrc');
checkhdl('sfir_fixed/symmetric_fir')
```

```
### Starting HDL check.
```

```
### Creating HDL Code Generation Check Report file://C:\HDL_Checks\hdlsrc\sfir_fixed\symmetric_fir
```

```
### HDL check for 'sfir_fixed' complete with 0 errors, 0 warnings, and 0 messages.
```

`checkhdl` completed successfully, which means that the model is compatible for HDL code generation. To generate code, use `makehdl`

```
makehdl('sfir_fixed/symmetric_fir')
```

```
### Generating HDL for 'sfir_fixed/symmetric_fir'.
```

```
### Using the config set for model <a href="matlab:configset.showParameterGroup('sfir_fixed', {
```

```

### Starting HDL check.
### Begin VHDL Code Generation for 'sfir_fixed'.
### Working on sfir_fixed/symmetric_fir as C:\HDL_Checks\hdlsrc\sfir_fixed\symmetric_fir.vhd.
### Creating HDL Code Generation Check Report file://C:\HDL_Checks\hdlsrc\sfir_fixed\symmetric_fir.vhd
### HDL check for 'sfir_fixed' complete with 0 errors, 0 warnings, and 0 messages.
### HDL code generation complete.

```

The generated VHDL® code for the `symmetric_fir` subsystem is saved in `hdlsrc\sfir_fixed\symmetric_fir.vhd`.

Close the model.

```
bdclose('sfir_fixed');
```

Input Arguments

dut – DUT model or subsystem name

character vector

Specified as subsystem name, top-level model name, or model reference name with full hierarchical path.

Example: 'top_level_name'

Example: 'top_level_name/subsysA/subsysB/codegen_subsys_name'

Name-Value Pair Arguments

Specify optional comma-separated pairs of `Name`, `Value` arguments. `Name` is the argument name and `Value` is the corresponding value. `Name` must appear inside quotes. You can specify several name and value pair arguments in any order as `Name1, Value1, ..., NameN, ValueN`.

Example: 'TargetLanguage', 'Verilog'

Target Options

HDLSubsystem – DUT Subsystem

character vector

Specify the Subsystem in your model to generate HDL code for. For more information, see the **Generate HDL for** section in “Target”.

TargetLanguage – Target language

'VHDL' (default) | 'Verilog'

Specify whether to generate VHDL or Verilog code. For more information, see the **Language** section in “Target”.

TargetDirectory – Output directory

'hdlsrc' (default) | character vector

Specify a path to write the generated files and HDL code into. For more information, see the **Folder** section in “Target”.

SplitEntityArch – Split VHDL entity and architecture into separate files

'off' (default) | 'on'

For more information, see **Split entity and architecture** in “Split entity and architecture”.

UseSingleLibrary — Generate VHDL code for model references into a single library

'off' (default) | 'on'

For more information, see “Generate VHDL code for model references into a single library”.

Code Generation Output Options

CodeGenerationOutput — Generation of HDL code and display of generated model

'GenerateHDLCode' (default) | 'GenerateHDLCodeAndDisplayGeneratedModel' |
'DisplayGeneratedModelOnly'

Specify whether you want to generate HDL code, or only display the generated model, or generate HDL code and display the generated model. For more information, see the **Generate HDL code** section in “Code Generation Output”.

GenerateHDLCode — Generate HDL code

'on' (default) | 'off'

Specify whether to generate HDL code for the model. For more information, see the **Generate HDL code** section in “Code Generation Output”.

GenerateValidationModel — Generate validation model

'off' (default) | 'on'

Specify whether to generate the validation model with HDL code. For more information, see the **Generate validation model** section in “Code Generation Output”.

Code Generation Report Options

HDLCodingStandard — Specify HDL coding standard

character vector

Specify whether the generated HDL code must conform to the Industry coding standard guidelines. For more information, see “Choose Coding Standard and Report Options”.

HDLCodingStandardCustomizations — Specify HDL coding standard customization object

hdlcoder.CodingStandard object

Specify the coding standards customization object to use with the Industry coding standard when generating HDL code. For more information, see `hdlcoder.CodingStandard`.

Traceability — Generate report with mapping links between HDL and model

'off' (default) | 'on'

Specify whether to generate a traceability report that has hyperlinks for navigating from code-to-model and from model-to-code. For more information, see “Generate traceability report”.

ResourceReport — Resource utilization report generation

'off' (default) | 'on'

Specify whether to generate a resource utilization report that displays the number of hardware resources that the generated HDL code uses. For more information, see “Generate resource utilization report”.

OptimizationReport — Optimization report generation`'off'` (default) | `'on'`

Specify whether to generate an optimization report that displays the effect of optimizations such as streaming, sharing, and distributed pipelining. For more information, see “Generate optimization report”.

HDLGenerateWebview — Include model Web view`'on'` (default) | `'off'`

Specify whether to generate a web view of the model in the Code Generation report to easily navigate between the code and model. For more information, see “Generate model Web view”.

Speed and Area Optimization**BalanceDelays — Delay balancing**`'on'` (default) | `'off'`

Specify whether to enable delay balancing on the model. For more information, see “Balance delays”.

DistributedPipeliningPriority — Specify priority for distributed pipelining algorithm`'NumericalIntegrity'` (default) | `'Performance'`

Specify whether to prioritize the distributed pipelining optimization for numerical integrity or performance. For more information, see the **Distributed pipelining priority** section in “Distributed Pipelining”.

HierarchicalDistPipelining — Hierarchical distributed pipelining`'off'` (default) | `'on'`

Specify whether to apply the hierarchical distributed pipelining optimization on the model. For more information, see “Distributed Pipelining”.

PreserveDesignDelays — Prevent distributed pipelining from moving design delays`'off'` (default) | `'on'`

Specify whether you want the code generator to distribute design delays in your model. For more information, see “Preserve design delays”.

ClockRatePipelining — Insert pipeline registers at the clock rate instead of the data rate for multi-cycle paths`'on'` (default) | `'off'`

Specify whether to insert pipeline registers at the clock rate or the data rate. For more information, see “Clock Rate Pipelining”.

MinimizeClockEnables — Omit clock enable logic for single-rate designs`'off'` (default) | `'on'`

For more information, see “Minimize Clock Enables and Reset Signals”.

RAMMappingThreshold — Minimum RAM size for mapping to RAMs instead of registers`256` (default) | positive integer

Specify, in bits, the minimum RAM size required for mapping to RAMs instead of registers. For more information, see the **RAM mapping threshold (bits)** section in “RAM Mapping”.

MapPipelineDelaysToRAM — Map pipeline registers in the generated HDL code to RAM

'off' (default) | 'on'

Specify whether to map pipeline registers in the generated HDL code to block RAMs on the FPGA. For more information, see the **Map pipeline delays to RAM** section in “RAM Mapping”.

HighlightFeedbackLoops — Highlight feedback loops inhibiting delay balancing and optimizations

'off' (default) | 'on'

Specify whether to highlight feedback loops in your design. For more information, see “Diagnostics for Optimizations”.

Coding Style**UserComment — HDL file header comment**

character vector

Specify comment lines in header of generated HDL and test bench files. For more information, see “Comment in header”.

UseAggregatesForConst — Represent constant values with aggregates

'off' (default) | 'on'

For more information, see **Represent constant values by aggregates** in “RTL Customizations for Constants and MATLAB Function Blocks”.

UseRisingEdge — Use VHDL rising_edge or falling_edge function to detect clock transitions

'off' (default) | 'on'

For more information, see **Use "rising_edge/falling_edge" style for registers** in “RTL Style”.

LoopUnrolling — Unroll VHDL FOR and GENERATE loops

'off' (default) | 'on'

For more information, see **Loop unrolling** in “RTL Style”.

UseVerilogTimescale — Generate 'timescale compiler directives

'on' (default) | 'off'

For more information, see **Use Verilog 'timescale directives** in “RTL Annotations”.

InlineConfigurations — Include VHDL configurations

'on' (default) | 'off'

For more information, see **Inline VHDL configuration** in “RTL Annotations”.

SafeZeroConcat — Type-safe syntax for concatenated zeros

'on' (default) | 'off'

For more information, see **Concatenate type safe zeros** in “RTL Annotations”.

ObfuscateGeneratedHDLCode — Obfuscate generated HDL code

'off' (default) | 'on'

Specify whether you want to obfuscate the generated HDL code. For more information, see **Generate obfuscated HDL code** in “RTL Annotations”.

DateComment — Include time stamp in header

'on' (default) | 'off'

For more information, see **Emit time/date stamp in header** in “RTL Annotations”.

ScalarizePorts — Flatten vector ports into scalar ports

'off' (default) | 'on'

For more information, see **Scalarize vector ports** in “RTL Style”.

MinimizeIntermediateSignals — Minimize intermediate signals

'off' (default) | 'on'

For more information, see **Minimize intermediate signals** in “RTL Style”.

RequirementComments — Link from code generation reports to requirement documents

'on' (default) | 'off'

For more information, see **Include requirements in block comments** in “RTL Annotations”.

InlineMATLABBlockCode — Inline HDL code for MATLAB Function blocks

'off' (default) | 'on'

For more information, see **Inline MATLAB Function block code** “RTL Customizations for Constants and MATLAB Function Blocks”.

MaskParameterAsGeneric — Reusable code generation for subsystems with identical mask parameters

'off' (default) | 'on'

For more information, see **Generate parameterized HDL code from masked subsystem** in “RTL Style”.

InitializeBlockRAM — Initial signal value generation for RAM blocks

'on' (default) | 'off'

For more information, see **Initialize all RAM blocks** in “RTL Customizations for RAMs”.

RAMArchitecture — RAM architecture

'WithClockEnable' (default) | 'WithoutClockEnable'

For more information, see **RAM Architecture** in “RTL Customizations for RAMs”.

Clocks and Reset**ClockEdge — Active clock edge**

'Rising' (default) | 'Falling'

Specify the active clock edge for the generated HDL code. For more information, see the **Clock edge** section in “Clock Settings and Timing Controller Postfix”.

ClockInputs — Single or multiple clock inputs

'Single' (default) | 'Multiple'

Specify whether to generate single or multiple clock inputs in the HDL code. For more information, see the **Clock inputs** section in “Clock Settings and Timing Controller Postfix”.

Oversampling — Oversampling factor for global clock

1 (default) | integer greater than or equal to 0

Frequency of global oversampling clock, specified as an integer multiple of the model’s base rate. For more information, see “Oversampling factor”.

ResetAssertedLevel — Asserted (active) level of reset

'active-high' (default) | 'active-low'

Specify whether to use an active-high or active-low asserted level for the reset input signal. For more information, see the **Reset asserted level** section in “Reset Settings”.

ResetType — Reset type

'async' (default) | 'sync'

Specify whether to use synchronous or asynchronous reset in the generated HDL code. For more information, see “Reset Settings”.

TriggerAsClock — Use trigger signal as clock in triggered subsystems

'off' (default) | 'on'

For more information, see “Use trigger signal as clock”.

TimingControllerArch — Generate reset for timing controller

'default' (default) | 'resettable'

For more information, see **Timing controller architecture** in “Timing Controller Settings”.

Test Bench

GenerateCoSimBlock — Generate HDL Cosimulation block

'off' (default) | 'on'

When you use this property with `makehdl`, HDL Coder does not a Cosimulation block. To generate a Cosimulation block, use `makehdltb`. With the Cosimulation block, you can simulate the DUT in Simulink with an HDL simulator.

For more information, see `GenerateCoSimBlock`.

GenerateCoSimModel — Generate HDL Cosimulation Model

'ModelSim' (default) | 'Incisive' | 'None'

When you use this property with `makehdl`, HDL Coder does not a Cosimulation model. To generate a Cosimulation model, use `makehdltb`. The model contains a Cosimulation block for the HDL simulator that you specify.

For more information, see `GenerateCoSimModel`.

SimulatorFlags — Options for generated compilation scripts

character vector

For more information, see `SimulatorFlags`.

TestBenchReferencePostFix — Suffix for test bench reference signals

'_ref' (default) | character vector

For more information, see TestBenchReferencePostFix.

Script Generation**EDAScriptGeneration — Enable or disable script generation for third-party tools**

'on' (default) | 'off'

For more information, see EDAScriptGeneration.

HDLCompileInit — Compilation script initialization text

'vlib %s\n' (default) | character vector

For more information, see HDLCompileInit.

HDLCompileTerm — Compilation script termination text

' ' (default) | character vector

For more information, see HDLCompileTerm.

HDLCompileFilePostfix — Postfix for compilation script file name

'_compile.do' (default) | character vector

For more information, see HDLCompileFilePostfix.

HDLCompileVerilogCmd — Verilog compilation command

'vlog %s %s\n' (default) | character vector

Verilog compilation command, specified as a character vector. The SimulatorFlags name-value pair specifies the first argument, and the module name specifies the second argument.

For more information, see HDLCompileVerilogCmd.

HDLCompileVHDLCmd — VHDL compilation command

'vcom %s %s\n' (default) | character vector

VHDL compilation command, specified as a character vector. The SimulatorFlags name-value pair specifies the first argument, and the entity name specifies the second argument.

For more information, see HDLCompileVHDLCmd.

HDLLintTool — HDL lint tool

'None' (default) | 'AscentLint' | 'Leda' | 'SpyGlass' | 'Custom'

For more information, see HDLLintTool.

HDLLintInit — HDL lint initialization name

character vector

HDL lint initialization name, specified as a character vector. The default is derived from the HDLLintTool name-value pair.

For more information, see HDLLintInit.

HDLLintCmd — HDL lint command

character vector

HDL lint command, specified as a character vector. The default is derived from the HDLLintTool name-value pair.

For more information, see HDLLintCmd.

HDLLintTerm — HDL lint termination name

character vector

HDL lint termination, specified as a character vector. The default is derived from the HDLLintTool name-value pair.

For more information, see HDLLintTerm.

HDLSynthTool — Synthesis tool

'None' (default) | 'ISE' | 'Libero' | 'Precision' | 'Quartus' | 'Synplify' | 'Vivado' | 'Custom'

For more information, see HDLSynthTool.

HDLSynthCmd — HDL synthesis command

character vector

HDL synthesis command, specified as a character vector. The default is derived from the HDLSynthTool name-value pair.

For more information, see HDLSynthCmd.

HDLSynthFilePostfix — Postfix for synthesis script file name

character vector

HDL synthesis script file name postfix, specified as a character vector. The default is derived from the HDLSynthTool name-value pair.

For more information, see HDLSynthFilePostfix.

HDLSynthInit — Synthesis script initialization name

character vector

Initialization for the HDL synthesis script, specified as a character vector. The default is derived from the HDLSynthTool name-value pair.

For more information, see HDLSynthInit.

HDLSynthTerm — Synthesis script termination name

character vector

Termination name for the HDL synthesis script. The default is derived from the HDLSynthTool name-value pair.

For more information, see HDLSynthTerm.

Generated Model**GeneratedModelNamePrefix — Prefix for generated model name**`'gm_'` (default) | character vector

For more information, see “Prefix for generated model name”.

Synthesis**SynthesisTool — Synthesis tool**`''` (default) | 'Altera Quartus II' | 'Xilinx ISE' | 'Xilinx Vivado'

Specify the synthesis tool for targeting the generated HDL code as a character vector. For more information, see “Tool and Device”.

SynthesisToolChipFamily — Synthesis tool chip family`''` (default) | character vector

Specify the synthesis tool chip family for the target device as a character vector. For more information, see the **Family** section in “Tool and Device”.

SynthesisToolDeviceName — Synthesis tool device name`''` (default) | character vector

Specify the synthesis tool device name for the target device as a character vector. For more information, see the **Device** section in “Tool and Device”.

SynthesisToolPackageName — Synthesis tool package name`''` (default) | character vector

Specify the synthesis tool package name for the target device as a character vector. For more information, see the **Package** section in “Tool and Device”.

SynthesisToolSpeedValue — Synthesis tool speed value`''` (default) | character vector

Specify the synthesis tool speed value for the target device as a character vector. For more information, see the **Speed** section in “Tool and Device”.

SynthesisToolSpeedValue — Synthesis tool speed value`''` (default) | character vector

Specify the synthesis tool speed value for the target device as a character vector. For more information, see the **Speed** section in “Tool and Device”.

TargetFrequency — Target frequency in MHz`''` (default) | character vector

Specify the target frequency in MHz as a character vector. For more information, see “Target Frequency”.

MulticyclePathInfo — Multicycle path constraint file generation`'off'` (default) | 'on'

Specify whether to generate a multicycle path constraints text file. For more information, see “Multicycle Path Constraints”.

MulticyclePathConstraints — Enable-based multicycle path constraint file generation`'off'` (default) | `'on'`

Specify whether to generate an enable-based multicycle path constraints file. For more information, see **Enable-based constraints** in “Multicycle Path Constraints”.

Port Names and Types**ClockEnableInputPort — Clock enable input port name**`'clk_enable'` (default) | character vector

Specify the clock enable input port name as a character vector. For more information, see “Clock Enable Settings”.

ClockEnableOutputPort — Clock enable output port name`'ce_out'` (default) | character vector

Clock enable output port name, specified as a character vector.

For more information, see “Clock Enable output port”.

ClockInputPort — Clock input port name`'clk'` (default) | character vector

Specify the clock input port name as a character vector. For more information, see “Clock Settings and Timing Controller Postfix”.

InputType — HDL data type for input ports`'wire'` or `'std_logic_vector'` (default) | `'signed/unsigned'`

VHDL inputs can have `'std_logic_vector'` or `'signed/unsigned'` data type. Verilog inputs must be `'wire'`.

For more information, see **Input data type** in “Input and Output Port Data Types”.

OutputType — HDL data type for output ports`'Same as input data type'` (default) | `'std_logic_vector'` | `'signed/unsigned'` | `'wire'`

VHDL output can be `'Same as input data type'`, `'std_logic_vector'` or `'signed/unsigned'`. Verilog output must be `'wire'`.

For more information, see **Output data type** in “Input and Output Port Data Types”.

ResetInputPort — Reset input port name`'reset'` (default) | character vector

Reset input port name, specified as a character vector.

For more information, see the **Reset input port** section in “Reset Settings”.

File and Variable Names**VerilogFileExtension — Verilog file extension**`' .v'` (default) | character vector

Specify the file name extension for generated Verilog files. For more information, see “Language-Specific Identifiers”.

VHDLFileExtension — VHDL file extension

' .vhd ' (default) | character vector

Specify the file name extension for generated VHDL files. For more information, see the **VHDLFileExtension** section in “Language-Specific Identifiers”.

VHDLArchitectureName — VHDL architecture name

' rtl ' (default) | character vector

For more information, see **VHDL architecture name** in “VHDL Architecture and Library Name”.

VHDLLibraryName — VHDL library name

' work ' (default) | character vector

For more information, see **VHDL library name** in “VHDL Architecture and Library Name”.

SplitEntityFilePostfix — Postfix for VHDL entity file names

' _entity ' (default) | character vector

For more information, see **Split entity file postfix** in “Split entity and architecture”.

SplitArchFilePostfix — Postfix for VHDL architecture file names

' _arch ' (default) | character vector

For more information, see **Split arch file postfix** in “Split entity and architecture”.

PackagePostfix — Postfix for package file name

' _pkg ' (default) | character vector

Specify the postfix for the package file name as a character vector. For more information, see the **Package Postfix** section in “Language-Specific Identifiers”.

HDLMapFilePostfix — Postfix for mapping file

' _map.txt ' (default) | character vector

For more information, see “Map file postfix”.

BlockGenerateLabel — Block label postfix for VHDL GENERATE statements

' _gen ' (default) | character vector

For more information, see **Block generate label** in “Generate Statement Labels”.

ClockProcessPostfix — Postfix for clock process names

' _process ' (default) | character vector

Specify the postfix for clocked process names as a character vector. For more information, see the **Clocked process postfix** section in “Clock Settings and Timing Controller Postfix”.

ComplexImagPostfix — Postfix for imaginary part of complex signal

' _im ' (default) | character vector

For more information, see **Complex imaginary part postfix** in “Complex Signals Postfix”.

ComplexRealPostfix — Postfix for imaginary part of complex signal names

' _re ' (default) | character vector

For more information, see **Complex real part postfix** in “Complex Signals Postfix”.

EntityConflictPostfix — Postfix for duplicate VHDL entity or Verilog module names

'_block' (default) | character vector

Specify the postfix as a character vector that resolves duplicate entity or module names. For more information, see the **Entity conflict postfix** section in “Language-Specific Identifiers”.

InstanceGenerateLabel — Instance section label postfix for VHDL GENERATE statements

'_gen' (default) | character vector

For more information, see **Instance generate label** in “Generate Statement Labels”.

InstancePostfix — Postfix for generated component instance names

' ' (default) | character vector

For more information, see **Instance postfix** in “Vector and Component Instances Labels”.

InstancePrefix — Prefix for generated component instance names

'u_' (default) | character vector

For more information, see **Instance prefix** in “Vector and Component Instances Labels”.

OutputGenerateLabel — Output assignment label postfix for VHDL GENERATE statements

'outputgen' (default) | character vector

For more information, see **Output generate label** in “Generate Statement Labels”.

PipelinePostfix — Postfix for input and output pipeline register names

'_pipe' (default) | character vector

For more information, see “Pipeline postfix”.

ReservedWordPostfix — Postfix for names conflicting with VHDL or Verilog reserved words

'_rsvd' (default) | character vector

For more information, see **Reserved word postfix** in “Language-Specific Identifiers”.

TimingControllerPostfix — Postfix for timing controller name

'_tc' (default) | character vector

For more information, see **Timing controller postfix** in “Clock Settings and Timing Controller Postfix”.

VectorPrefix — Prefix for vector names

'vector_of_' (default) | character vector

For more information, see **Vector prefix** in “Vector and Component Instances Labels”.

EnablePrefix — Prefix for internal enable signals

'enb' (default) | character vector

Prefix for internal clock enable and control flow enable signals, specified as a character vector. For more information, see “Clock Enable Settings”.

ModulePrefix — Prefix for modules or entity names

' ' (default) | character vector

Specify a prefix for every module or entity name in the generated HDL code. HDL Coder also applies this prefix to generated script file names

For more information, see **ModulePrefix** in “Language-Specific Identifiers”.

See Also

checkhdl | makehdltb

Introduced in R2006b

makehdltb

Generate HDL test bench from model or subsystem

Syntax

```
makehdltb(dut)
makehdltb(dut,Name,Value)
```

Description

`makehdltb(dut)` generates an HDL test bench from the specified subsystem or model reference.

Note If you have not previously executed `makehdl` within the current MATLAB session, `makehdltb` calls `makehdl` to generate model code before generating the test bench code. Properties passed in to `makehdl` persist after `makehdl` executes, and (unless explicitly overridden) are passed to subsequent `makehdl` calls during the same MATLAB session.

`makehdltb(dut,Name,Value)` generates an HDL test bench from the specified subsystem or model reference with options specified by one or more name-value pair arguments.

Examples

Generate VHDL Test Bench

Generate VHDL DUT and test bench for a subsystem.

Use `makehdl` to generate VHDL code for the subsystem `symmetric_fir`.

```
makehdl('sfir_fixed/symmetric_fir')

### Generating HDL for 'sfir_fixed/symmetric_fir'.
### Starting HDL check.
### HDL check for 'sfir_fixed' complete with 0 errors, 0 warnings,
and 0 messages.
### Begin VHDL Code Generation for 'sfir_fixed'.
### Working on sfir_fixed/symmetric_fir as
   hdlsrc\sfir_fixed\symmetric_fir.vhd
### HDL code generation complete.
```

After `makehdl` is complete, use `makehdltb` to generate a VHDL test bench for the same subsystem.

```
makehdltb('sfir_fixed/symmetric_fir')

### Begin TestBench generation.
### Generating HDL TestBench for 'sfir_fixed/symmetric_fir'.
### Begin simulation of the model 'gm_sfir_fixed'...
### Collecting data...
### Generating test bench: hdlsrc\sfir_fixed\symmetric_fir_tb.vhd
```

```
### Creating stimulus vectors...
### HDL TestBench generation complete.
```

The generated VHDL test bench code is saved in the `hdlsrc` folder.

Generate Verilog Test Bench

Generate Verilog DUT and test bench for a subsystem.

Use `makehdl` to generate Verilog code for the subsystem `symmetric_fir`.

```
makehdl('sfir_fixed/symmetric_fir','TargetLanguage','Verilog')

### Generating HDL for 'sfir_fixed/symmetric_fir'.
### Starting HDL check.
### HDL check for 'sfir_fixed' complete with 0 errors, 0 warnings,
    and 0 messages.
### Begin Verilog Code Generation for 'sfir_fixed'.
### Working on sfir_fixed/symmetric_fir as
    hdlsrc\sfir_fixed\symmetric_fir.v
### HDL code generation complete.
```

After `makehdl` is complete, use `makehdltb` to generate a Verilog test bench for the same subsystem.

```
makehdltb('sfir_fixed/symmetric_fir','TargetLanguage','Verilog')

### Begin TestBench generation.
### Generating HDL TestBench for 'sfir_fixed/symmetric_fir'.
### Begin simulation of the model 'gm_sfir_fixed'...
### Collecting data...
### Generating test bench: hdlsrc\sfir_fixed\symmetric_fir_tb.v
### Creating stimulus vectors...
### HDL TestBench generation complete.
```

The generated Verilog test bench code is saved in the `hdlsrc\sfir_fixed` folder.

Generate a SystemVerilog DPI Test Bench

Generate SystemVerilog DPI test bench for a subsystem.

Consider this option if generation or simulation of the default HDL test bench takes a long time. Generation of a DPI test bench can be faster than the default version because it does not run a Simulink simulation to create the test bench data. Simulation of a DPI test bench with a large data set is faster than the default version because it does not store the input or expected data in a separate file. For requirements to use this feature, see the `GenerateSVPITestBench` property.

Use `makehdl` to generate Verilog code for the subsystem `symmetric_fir`.

```
makehdl('sfir_fixed/symmetric_fir','TargetLanguage','Verilog')

### Generating HDL for 'sfir_fixed/symmetric_fir'.
### Starting HDL check.
### HDL check for 'sfir_fixed' complete with 0 errors, 0 warnings,
    and 0 messages.
```



```
### Begin Verilog Code Generation for 'sfir_fixed'.
### Working on sfir_fixed/symmetric_fir as
  hdlsrc\sfir_fixed\symmetric_fir.v
### HDL code generation complete.
```

After the code is generated, use `makehdltb` to generate a test bench for the same subsystem. Specify your HDL simulator so that the coder can generate scripts to build and run the generated SystemVerilog and C code. Disable generation of the default test bench.

```
makehdltb('sfir_fixed/symmetric_fir','TargetLanguage','Verilog',...
          'GenerateSVDPITestBench','ModelSim','GenerateHDLTestBench','off')

### Start checking model compatibility with SystemVerilog DPI testbench
### Finished checking model compatibility with SystemVerilog DPI testbench
### Preparing generated model for SystemVerilog DPI component generation
### Generating SystemVerilog DPI component
### Starting build procedure for model: gm_sfir_fixed_ref
### Starting SystemVerilog DPI Component Generation
### Generating DPI H Wrapper gm_sfir_fixed_ref_dpi.h
### Generating DPI C Wrapper gm_sfir_fixed_ref_dpi.c
### Generating SystemVerilog module gm_sfir_fixed_ref_dpi.sv using template C:\matlab\toolbox\hdl
### Generating makefiles for: gm_sfir_fixed_ref_dpi
### Invoking make to build the DPI Shared Library
### Successful completion of build procedure for model: gm_sfir_fixed_ref
### Working on symmetric_fir_dpi_tb as hdlsrc\sfir_fixed\symmetric_fir_dpi_tb.sv.
### Generating SystemVerilog DPI testbench simulation script for ModelSim/Questasim hdlsrc\sfir_

### HDL TestBench generation complete.
```

The generated SystemVerilog and C test bench files, and the build scripts, are saved in the `hdlsrc\sfir_fixed` folder.

Input Arguments

dut — DUT subsystem or model reference name

character vector

DUT subsystem or model reference name, specified as a character vector, with full hierarchical path.

Example: 'modelName/subsysTarget'

Example: 'modelName/subsysA/subsysB/subsysTarget'

Name-Value Pair Arguments

Specify optional comma-separated pairs of `Name`, `Value` arguments. `Name` is the argument name and `Value` is the corresponding value. `Name` must appear inside quotes. You can specify several name and value pair arguments in any order as `Name1, Value1, ..., NameN, ValueN`.

Example: 'TargetLanguage', 'Verilog'

Basic Options

TargetLanguage — Target language

'VHDL' (default) | 'Verilog'

Specify whether to generate VHDL or Verilog code. For more information, see the **Language** section in "Target".

TargetDirectory – Output directory`'hdlsrc'` (default) | character vector

Specify a path to write the generated files and HDL code into. For more information, see the **Folder** section in “Target”.

SplitEntityArch – Split VHDL entity and architecture into separate files`'off'` (default) | `'on'`

For more information, see **Split entity and architecture** in “Split entity and architecture”.

Test Bench Generation**GenerateHDLTestBench – Generate HDL test bench**`'on'` (default) | `'off'`

The coder generates an HDL test bench by running a Simulink simulation to capture input vectors and expected output data for your DUT. For more information, see **HDL test bench** “Test Bench Generation Output”.

GenerateSVPITestBench – Generate SystemVerilog DPI test bench`'none'` (default) | `'ModelSim'` | `'Incisive'` | `'VCS'` | `'Vivado Simulator'`

When you set this property, the coder generates a direct programming interface (DPI) component for your entire Simulink model, including your DUT and data sources. Your entire model must support C code generation with Simulink Coder™. The coder generates a SystemVerilog test bench that compares the output of the DPI component with the output of the HDL implementation of your DUT. The coder also builds shared libraries and generates a simulation script for the simulator you select.

Consider using this option if the default HDL test bench takes a long time to generate or simulate. Generation of a DPI test bench is sometimes faster than the default version because it does not run a full Simulink simulation to create the test bench data. Simulation of a DPI test bench with a large data set is faster than the default version because it does not store the input or expected data in a separate file. For an example, see “Generate a SystemVerilog DPI Test Bench” on page 2-88.

To use this feature, you must have HDL Verifier™ and Simulink Coder licenses. To run the SystemVerilog testbench with generated VHDL code, you must have a mixed-language simulation license for your HDL simulator.

Limitations This test bench is not supported when you generate HDL code for the top-level Simulink model. Your DUT subsystem must meet the following conditions:

- Input and output data types of the DUT cannot be larger than 64 bits.
 - Input and output ports of the DUT cannot use enumerated data types.
 - Input and output ports cannot be single-precision or double-precision data types.
 - The DUT cannot have multiple clocks. You must set the **Clock inputs** code generation option to `Single`.
 - **Use trigger signal as clock** must not be selected.
 - If the DUT uses vector ports, you must use **Scalarize vector ports** to flatten the interface.
-

GenerateCoSimBlock — Generate HDL Cosimulation block

'off' (default) | 'on'

Generate an HDL Cosimulation block so you can simulate the DUT in Simulink with an HDL simulator.

For more information, see `GenerateCoSimBlock`.

GenerateCoSimModel — Generate HDL Cosimulation model

'ModelSim' (default) | 'Incisive' | 'None'

Generate a model containing an HDL Cosimulation block for the specified HDL simulator.

For more information, see `GenerateCoSimModel`.

HDLCodeCoverage — Enable code coverage on the generated test bench

'off' (default) | 'on'

Include code coverage switches in the generated build-and-run scripts. These switches turn on code coverage for the generated test bench. Specify your HDL simulator in the `SimulationTool` property. The coder generates build-and-run scripts for the simulator you specify.

SimulationTool — HDL simulator where you will run the generated test bench

'ModelSim' (default) | 'Incisive' | 'VCS' | 'Vivado' | 'Custom'

This property applies to generated test benches. 'VCS' and 'Vivado' are supported only for SystemVerilog DPI test benches. When you select 'Custom', the tool uses the custom script settings. See the “Script Generation” properties.

Test Bench Configuration**ForceClock — Force clock input**

'on' (default) | 'off'

Specify that the generated test bench drives the clock enable input based on `ClockLowTime` and `ClockHighTime`.

For more information, see `ForceClock`.

ClockHighTime — Clock high time

5 (default) | positive integer

Clock high time during a clock period, specified in nanoseconds.

For more information, see `ClockHighTime`.

ClockLowTime — Clock low time

5 (default) | positive integer

Clock low time during a clock period, specified in nanoseconds.

For more information, see `ClockLowTime`.

ForceClockEnable — Force clock enable input

'on' (default) | 'off'

Specify that the generated test bench drives the clock enable input.

For more information, see `ForceClockEnable`.

ClockInputs — Single or multiple clock inputs

'Single' (default) | 'Multiple'

Specify whether to generate single or multiple clock inputs in the HDL code. For more information, see the **Clock inputs** section in “Clock Settings and Timing Controller Postfix”.

ForceReset — Force reset input

'on' (default) | 'off'

Specify that the generated test bench drives the reset input.

For more information, see `ForceReset`.

ResetLength — Reset asserted time length

2 (default) | integer greater than or equal to 0

Length of time that reset is asserted, specified as the number of clock cycles.

For more information, see **Reset length** in “Clock Enable and Reset Input Signals”.

ResetAssertedLevel — Asserted (active) level of reset

'active-high' (default) | 'active-low'

Specify whether to use an active-high or active-low asserted level for the reset input signal. For more information, see the **Reset asserted level** section in “Reset Settings”.

HoldInputDataBetweenSamples — Hold valid data for signals clocked at slower rate

'on' (default) | 'off'

For more information, see `HoldInputDataBetweenSamples`.

HoldTime — Hold time for inputs and forced reset

2 (default) | positive integer

Hold time for inputs and forced reset, specified in nanoseconds.

For more information, see `HoldTime`.

IgnoreDataChecking — Time to wait after clock enable before checking output data

0 (default) | positive integer

Time after clock enable is asserted before starting output data checks, specified in number of samples.

For more information, see `IgnoreDataChecking`.

InitializeTestBenchInputs — Initialize test bench inputs to 0

'off' (default) | 'on'

For more information, see `InitializeTestBenchInputs`.

MultifileTestBench — Divide generated test bench into helper functions, data, and HDL test bench files

'off' (default) | 'on'

For more information, see MultifileTestBench.

UseFileIOInTestBench — Use file I/O to read/write test bench data

'on' (default) | 'off'

For more information, see UseFileIOInTestBench.

TestBenchClockEnableDelay — Number of clock cycles between deassertion of reset and assertion of clock enable

1 (default) | positive integer

For more information, see TestBenchClockEnableDelay.

TestBenchDataPostFix — Postfix for test bench data file name

'_data' (default) | character vector

For more information, see TestBenchDataPostFix.

TestBenchPostFix — Suffix for test bench name

'_tb' (default) | character vector

For more information, see TestBenchPostFix.

Coding Style**UseVerilogTimescale — Generate 'timescale compiler directives**

'on' (default) | 'off'

For more information, see **Use Verilog 'timescale directives** in “RTL Annotations”.**DateComment — Include time stamp in header**

'on' (default) | 'off'

For more information, see **Emit time/date stamp in header** in “RTL Annotations”.**InlineConfigurations — Include VHDL configurations**

'on' (default) | 'off'

For more information, see **Inline VHDL configuration** in “RTL Annotations”.**ScalarizePorts — Flatten vector ports into scalar ports**

'off' (default) | 'on'

For more information, see **Scalarize vector ports** in “RTL Style”.**Script Generation****HDLCompileInit — Compilation script initialization text**

'vlib %s\n' (default) | character vector

For more information, see HDLCompileInit.

HDLCompileTerm — Compilation script termination text`' ' (default) | character vector`

For more information, see `HDLCompileTerm`.

HDLCompileFilePostfix — Postfix for compilation script file name`'_compile.do' (default) | character vector`

For more information, see `HDLCompileFilePostfix`.

HDLCompileVerilogCmd — Verilog compilation command`'vlog %s %s\n' (default) | character vector`

Verilog compilation command, specified as a character vector. The `SimulatorFlags` name-value pair specifies the first argument, and the module name specifies the second argument.

For more information, see `HDLCompileVerilogCmd`.

HDLCompileVHDLCmd — VHDL compilation command`'vcom %s %s\n' (default) | character vector`

VHDL compilation command, specified as a character vector. The `SimulatorFlags` name-value pair specifies the first argument, and the entity name specifies the second argument.

For more information, see `HDLCompileVHDLCmd`.

HDLSimCmd — HDL simulation command`'vsim -novopt %s.%s\n' (default) | character vector`

The HDL simulation command, specified as a character vector.

For more information, see `HDLSimCmd`.

HDLSimInit — HDL simulation script initialization name`['onbreak resume\n', 'onerror resume\n'] (default) | character vector`

Initialization for the HDL simulation script, specified as a character vector.

For more information, see `HDLSimInit`.

HDLSimTerm — HDL simulation script termination name`'run -all' (default) | character vector`

The termination name for the HDL simulation command, specified as a character vector.

For more information, see `HDLSimTerm`.

HDLSimFilePostfix — Postscript for HDL simulation script`'_sim.do' (default) | character vector`

For more information, see `HDLSimFilePostfix`.

HDLSimViewWaveCmd — HDL simulation waveform viewing command`'add wave sim:%s\n' (default) | character vector`

Waveform viewing command, specified as a character vector. The implicit argument adds the signal paths for the DUT top-level input, output, and output reference signals.

For more information, see HDLSimViewWaveCmd.

Port Names and Types

ClockEnableInputPort — Clock enable input port name

'clk_enable' (default) | character vector

Specify the clock enable input port name as a character vector. For more information, see “Clock Enable Settings”.

ClockEnableOutputPort — Clock enable output port name

'ce_out' (default) | character vector

Clock enable output port name, specified as a character vector.

For more information, see “Clock Enable output port”.

ClockInputPort — Clock input port name

'clk' (default) | character vector

Specify the clock input port name as a character vector. For more information, see “Clock Settings and Timing Controller Postfix”.

ResetInputPort — Reset input port name

'reset' (default) | character vector

Reset input port name, specified as a character vector.

For more information, see the **Reset input port** section in “Reset Settings”.

File and Variable Names

VerilogFileExtension — Verilog file extension

' .v ' (default) | character vector

Specify the file name extension for generated Verilog files. For more information, see “Language-Specific Identifiers”.

VHDLFileExtension — VHDL file extension

' .vhd ' (default) | character vector

Specify the file name extension for generated VHDL files. For more information, see the **VHDLFileExtension** section in “Language-Specific Identifiers”.

VHDLArchitectureName — VHDL architecture name

' rtl ' (default) | character vector

For more information, see **VHDL architecture name** in “VHDL Architecture and Library Name”.

VHDLLibraryName — VHDL library name

' work ' (default) | character vector

For more information, see **VHDL library name** in “VHDL Architecture and Library Name”.

SplitEntityFilePostfix — Postfix for VHDL entity file names

'_entity' (default) | character vector

For more information, see **Split entity file postfix** in “Split entity and architecture”.

SplitArchFilePostfix — Postfix for VHDL architecture file names

'_arch' (default) | character vector

For more information, see **Split arch file postfix** in “Split entity and architecture”.

PackagePostfix — Postfix for package file name

'_pkg' (default) | character vector

Specify the postfix for the package file name as a character vector. For more information, see the **Package Postfix** section in “Language-Specific Identifiers”.

ComplexImagPostfix — Postfix for imaginary part of complex signal

'_im' (default) | character vector

For more information, see **Complex imaginary part postfix** in “Complex Signals Postfix”.

ComplexRealPostfix — Postfix for imaginary part of complex signal names

'_re' (default) | character vector

For more information, see **Complex real part postfix** in “Complex Signals Postfix”.

EnablePrefix — Prefix for internal enable signals

'_enb' (default) | character vector

Prefix for internal clock enable and control flow enable signals, specified as a character vector. For more information, see “Clock Enable Settings”.

See Also

makehdl

Introduced in R2006b

Simulink.ModelReference.protect

Obscure referenced model contents to hide intellectual property

Syntax

```
Simulink.ModelReference.protect(model)
Simulink.ModelReference.protect(model,Name,Value)

[harnessHandle] = Simulink.ModelReference.protect(model,'Harness',true)
[~,neededVars] = Simulink.ModelReference.protect(model)
```

Description

`Simulink.ModelReference.protect(model)` creates a protected model from the specified model. It places the protected model in the current working folder. The protected model has the same name as the source model. It has the extension `.slxp`.

`Simulink.ModelReference.protect(model,Name,Value)` uses additional options specified by one or more `Name,Value` pair arguments.

`[harnessHandle] = Simulink.ModelReference.protect(model,'Harness',true)` creates a harness model for the protected model. It returns the handle of the harnessed model in `harnessHandle`.

`[~,neededVars] = Simulink.ModelReference.protect(model)` returns a cell array that includes the names of base workspace variables used by the protected model.

Examples

Protect Referenced Model

Protect a referenced model and place the protected model in the current working folder.

```
sldemo_mdhref_bus;
model= 'sldemo_mdhref_counter_bus'
```

```
Simulink.ModelReference.protect(model);
```

A protected model named `sldemo_mdhref_counter_bus.slxp` is created. The protected model file is placed in the current working folder.

Place Protected Model in Specified Folder

Protect a referenced model and place the protected model in a specified folder.

```
sldemo_mdhref_bus;
model= 'sldemo_mdhref_counter_bus'

Simulink.ModelReference.protect(model,'Path','C:\Work');
```

A protected model named `sldemo_mdhref_counter_bus.slxp` is created. The protected model file is placed in `C:\Work`.

Generate Code for Protected Model

Protect a referenced model, generate code for it in normal mode, and obfuscate the code.

```
sldemo_mdhref_bus;
model= 'sldemo_mdhref_counter_bus'

Simulink.ModelReference.protect(model, 'Path', 'C:\Work', 'Mode', 'CodeGeneration', ...
'ObfuscateCode', true);
```

A protected model named `sldemo_mdhref_counter_bus.slxp` is created. The protected model file is placed in the `C:\Work` folder. The protected model runs as a child of the parent model. The code generated for the protected model is obfuscated by the software.

Generate HDL Code for Protected Model

Protect a referenced model, and generate HDL code for it in normal mode.

```
parent_model= 'hdlcoder_protected_model_parent_harness';
reference_model_to_protect = 'hdlcoder_referenced_model_gain';

Simulink.ModelReference.protect(reference_model_to_protect, ...
'Mode', 'HDLCodeGeneration')
```

A protected model named `hdlcoder_referenced_model_gain.slxp` is created. The protected model file is placed in the same folder as the parent model and the referenced model. The protected model runs as a child of the parent model.

Set the **hdl** option to `true` with **Mode** set to `CodeGeneration` to enable both C code generation and HDL code generation support for a protected model that you create.

```
parent_model= 'hdlcoder_protected_model_parent_harness';
reference_model_to_protect = 'hdlcoder_referenced_model_gain';

Simulink.ModelReference.protect(reference_model_to_protect, ...
'Mode', 'CodeGeneration', 'hdl', true)
```

Control Code Visibility for Protected Model

Control code visibility by allowing users to view only binary files and headers in the code generated for a protected model.

```
sldemo_mdhref_bus;
model= 'sldemo_mdhref_counter_bus'

Simulink.ModelReference.protect(model, 'Mode', 'CodeGeneration', 'OutputFormat', ...
'CompiledBinaries');
```

A protected model named `sldemo_mdhref_counter_bus.slxp` is created. The protected model file is placed in the current working folder. Users can view only binary files and headers in the code generated for the protected model.

Create Harness Model for Protected Model

Create a harness model for a protected model and generate an HTML report.

```
sldemo_mdhref_bus;
modelPath= 'sldemo_mdhref_bus/CounterA'

[harnessHandle] = Simulink.ModelReference.protect(modelPath, 'Path', 'C:\Work', ...
'Harness', true, 'Report', true);
```

A protected model named `sldemo_mdhref_counter_bus.slxp` is created, along with an untitled harness model. The protected model file is placed in the `C:\Work` folder. The folder also contains an HTML report. The handle of the harness model is returned in `harnessHandle`.

Input Arguments

model — Model name

string or character vector (default)

Model name, specified as a string or character vector. It contains the name of a model or the path name of a Model block that references the model to be protected.

Name-Value Pair Arguments

Specify optional comma-separated pairs of **Name**, **Value** arguments. **Name** is the argument name and **Value** is the corresponding value. **Name** must appear inside quotes. You can specify several name and value pair arguments in any order as `Name1, Value1, ..., NameN, ValueN`.

Example: `'Mode', 'CodeGeneration', 'OutputFormat', 'Binaries', 'ObfuscateCode', true` specifies that obfuscated code be generated for the protected model. It also specifies that only binary files and headers in the generated code be visible to users of the protected model.

Harness — Option to create a harness model

false (default) | true

Option to create a harness model, specified as a Boolean value.

Example: `'Harness', true`

Mode — Model protection mode

'Normal' (default) | 'Accelerator' | 'CodeGeneration' | 'HDLCodeGeneration' | 'ViewOnly'

Model protection mode. Specify one of the following values:

- 'Normal': If the top model is running in 'Normal' mode, the protected model runs as a child of the top model.
- 'Accelerator': The top model can run in 'Normal', 'Accelerator', or 'Rapid Accelerator' mode.

- `'CodeGeneration'`: The top model can run in `'Normal'`, `'Accelerator'`, or `'Rapid Accelerator'` mode and support code generation.
- `'HDLCodeGeneration'`: The top model can run in `'Normal'`, `'Accelerator'`, or `'Rapid Accelerator'` mode and support HDL code generation. (Requires HDL Coder license)
- `'ViewOnly'`: Turns off Simulate and Generate code functionality modes. Turns on the read-only view mode.

Example: `'Mode', 'Accelerator'`

CodeInterface — Interface through which generated code is accessed by Model block

`'Model reference'` (default) | `'Top model'`

Applies only if the system target file (`SystemTargetFile`) is set to an ERT-based system target file (for example, `ert.tlc`). Requires Embedded Coder® license.

Specify one of the following values:

- `'Model reference'`: Code access through the model reference code interface, which allows use of the protected model within a model reference hierarchy. Users of the protected model can generate code from a parent model that contains the protected model. In addition, users can run Model block SIL/PIL simulations with the protected model.
- `'Top model'`: Code access through the standalone interface. Users of the protected model can run Model block SIL/PIL simulations with the protected model.

Example: `'CodeInterface', 'Top model'`

ObfuscateCode — Option to obfuscate generated code

`true` (default) | `false`

Option to obfuscate generated code, specified as a Boolean value. Applicable only when code generation during protection is enabled. Obfuscation is not supported for HDL code generation.

Example: `'ObfuscateCode', true`

Path — Folder for protected model

current working folder (default) | string or character vector

Folder for protected model, specified as a string or character vector.

Example: `'Path', 'C:\Work'`

Report — Option to generate a report

`false` (default) | `true`

Option to generate a report, specified as a Boolean value.

To view the report, right-click the protected-model badge icon and select **Display Report**. Or, call the `Simulink.ProtectedModel.open` function with the report option.

The report is generated in HTML format. It includes information on the environment, functionality, and interface for the protected model.

Example: `'Report', true`

hdl — Option to generate HDL code

`false` (default) | `true`

Option to generate HDL code, specified as a Boolean value.

This option requires HDL Coder license. When you enable this option, make sure that you specify the **Mode**. You can set this option to `true` in conjunction with the **Mode** set to `CodeGeneration` to enable both C code and HDL code generation support for the protected model.

If you want to enable only simulation and HDL code generation support, but not C code generation, set **Mode** to `HDLCodeGeneration`. You do not have to set the **hdl** option to `true`.

Example: `'hdl',true`

OutputFormat — Protected code visibility

`'CompiledBinaries'` (default) | `'MinimalCode'` | `'AllReferencedHeaders'`

Note This argument affects the output only when you specify **Mode** as `'Accelerator'` or `'CodeGeneration'`. When you specify **Mode** as `'Normal'`, only a MEX-file is part of the output package.

Protected code visibility. This argument determines what part of the code generated for a protected model is visible to users. Specify one of the following values:

- `'CompiledBinaries'`: Only binary files and headers are visible.
- `'MinimalCode'`: Includes only the minimal header files required to build the code with the chosen build settings. All code in the build folder is visible. Users can inspect the code in the protected model report and recompile it for their purposes.
- `'AllReferencedHeaders'`: Includes header files found on the include path. All code in the build folder is visible. All headers referenced by the code are also visible.

Example: `'OutputFormat','AllReferencedHeaders'`

Webview — Option to include a Web view

`false` (default) | `true`

Option to include a read-only view of protected model, specified as a Boolean value.

To open the Web view of a protected model, use one of the following methods:

- Right-click the protected-model badge icon and select **Show Web view**.
- Use the `Simulink.ProtectedModel.open` function. For example, to display the Web view for protected model `sldemo_mdhref_counter`, you can call:

```
Simulink.ProtectedModel.open('sldemo_mdhref_counter', 'webview');
```

- Double-click the `.slxp` protected model file in the Current Folder browser.
- In the Block Parameter dialog box for the protected model, click **Open Model**.

Example: `'Webview',true`

Encrypt — Option to encrypt protected model

`false` (default) | `true`

Option to encrypt a protected model, specified as a Boolean value. Applicable when you have specified a password during protection, or by using the following methods:

- Password for read-only view of model:
`Simulink.ModelReference.ProtectedModel.setPasswordForView`
- Password for simulation:
`Simulink.ModelReference.ProtectedModel.setPasswordForSimulation`
- Password for code generation:
`Simulink.ModelReference.ProtectedModel.setPasswordForCodeGeneration`
- Password for HDL code generation:
`Simulink.ModelReference.ProtectedModel.setPasswordForHDLCodeGeneration`

Example: `'Encrypt',true`

CustomPostProcessingHook — Option to add postprocessing function for protected model files

function handle

Option to add a postprocessing function for protected model files, specified as a function handle. The function accepts a `Simulink.ModelReference.ProtectedModel.HookInfo` object as an input variable. This object provides information on the source code files and other files generated during protected model creation. It also provides information on exported symbols that you must not modify. Prior to packaging the protected model, the postprocessing function is called.

For a protected model with a top model interface, the `Simulink.ModelReference.ProtectedModel.HookInfo` object cannot provide information on exported symbols.

Example: `'CustomPostProcessingHook',@(protectedMdlInf)myHook(protectedMdlInf)`

Modifiable — Option to create a modifiable protected model

false (default) | true

Option to create a modifiable protected model, specified as a Boolean value. To use this option:

- Add a password for modification by using the `Simulink.ModelReference.ProtectedModel.setPasswordForModify` function. If a password has not been added at the time that you create the modifiable protected model, you are prompted to create one.
- Modify the options of your protected model by first providing the modification password by using the `Simulink.ModelReference.ProtectedModel.setPasswordForModify` function. Then use the `Simulink.ModelReference.modifyProtectedModel` function to make your option changes.

Example: `'Modifiable',true`

Callbacks — Option to specify protected model callbacks

cell array

Option to specify callbacks for a protected model, specified as a cell array of `Simulink.ProtectedModel.Callback` objects.

Example: `'Callbacks',{pmcallback_sim, pmcallback_cg}`

Sign — Option to sign with digital certificate

character vector | string scalar

The digital certificate to use to sign a protected model, specified as a character vector or string scalar. If the certificate file is password-protected, use the `Simulink.ModelReference.ProtectedModel.setPasswordForCertificate` function to provide the password before you use the certificate.

Example: `'Sign','my_certificate.pfx'`

Output Arguments

harnessHandle — Handle of the harness model

double

Handle of the harness model, returned as a double or 0, depending on the value of `Harness`.

If `Harness` is `true`, the value is the handle of the harness model. Otherwise, the value is 0.

neededVars — Names of base workspace variables

cell array

Names of base workspace variables that the protected model uses, returned as a cell array.

The cell array can also include variables that the protected model does not use.

Alternatives

“Protect Models to Conceal Contents” (Simulink Coder)

See Also

`Simulink.ModelReference.ProtectedModel.clearPasswords` |
`Simulink.ModelReference.ProtectedModel.clearPasswordsForModel` |
`Simulink.ModelReference.ProtectedModel.setPasswordForCodeGeneration` |
`Simulink.ModelReference.ProtectedModel.setPasswordForHDLCodeGeneration` |
`Simulink.ModelReference.ProtectedModel.setPasswordForModify` |
`Simulink.ModelReference.ProtectedModel.setPasswordForSimulation` |
`Simulink.ModelReference.ProtectedModel.setPasswordForView` |
`Simulink.ModelReference.modifyProtectedModel`

Topics

“Protect Models to Conceal Contents” (Simulink Coder)
 “Protected Models for Model Reference” (Simulink)
 “Test Protected Models” (Simulink Coder)
 “Package and Share Protected Models” (Simulink Coder)
 “Specify Custom Obfuscators for Protected Models” (Simulink Coder)
 “Configure and Run SIL Simulation” (Embedded Coder)
 “Define Callbacks for Protected Models” (Simulink Coder)
 “Reference Protected Models from Third Parties” (Simulink)
 “Code Interfaces for SIL and PIL” (Embedded Coder)

Introduced in R2012b

Simulink.ModelReference.modifyProtectedModel

Modify existing protected model

Syntax

```
Simulink.ModelReference.modifyProtectedModel(model)
Simulink.ModelReference.modifyProtectedModel(model,Name,Value)

[harnessHandle] = Simulink.ModelReference.modifyProtectedModel(model,'
Harness',true)
[~,neededVars] = Simulink.ModelReference.modifyProtectedModel(model)
```

Description

`Simulink.ModelReference.modifyProtectedModel(model)` modifies options for an existing protected model created from the specified model. If `Name,Value` pair arguments are not specified, the modified protected model is updated with default values and supports only simulation.

`Simulink.ModelReference.modifyProtectedModel(model,Name,Value)` uses additional options specified by one or more `Name,Value` pair arguments. These options are the same options that are provided by the `Simulink.ModelReference.protect` function. However, these options have additional options to change encryption passwords for read-only view, simulation, and code generation. When you add functionality to the protected model or change encryption passwords, the unprotected model must be available. The software searches for the model on the MATLAB path. If the model is not found, the software reports an error.

`[harnessHandle] = Simulink.ModelReference.modifyProtectedModel(model,'Harness',true)` creates a harness model for the protected model. It returns the handle of the harnessed model in `harnessHandle`.

`[~,neededVars] = Simulink.ModelReference.modifyProtectedModel(model)` returns a cell array that includes the names of base workspace variables used by the protected model.

Examples

Update Protected Model with Default Values

Create a modifiable protected model with support for code generation, then reset it to default values.

Add the password for when a protected model is modified. If you skip this step, you are prompted to set a password when a modifiable protected model is created.

```
Simulink.ModelReference.ProtectedModel.setPasswordForModify(...
'sldemo_mdhref_counter','password');
```

Create a modifiable protected model with support for code generation and Web view.

```
Simulink.ModelReference.protect('sldemo_mdhref_counter','Mode',...
'CodeGeneration','Modifiable',true,'Report',true);
```

Provide the password to modify the protected model.

```
Simulink.ModelReference.ProtectedModel.setPasswordForModify(...
'sldemo_mdref_counter', 'password');
```

Modify the model to use default values.

```
Simulink.ModelReference.modifyProtectedModel(...
'sldemo_mdref_counter');
```

The resulting protected model is updated with default values and supports only simulation.

Remove Functionality from Protected Model

Create a modifiable protected model with support for code generation and Web view, then modify it to remove the Web view support.

Add the password for when a protected model is modified. If you skip this step, you are prompted to set a password when a modifiable protected model is created.

```
Simulink.ModelReference.ProtectedModel.setPasswordForModify(...
'sldemo_mdref_counter', 'password');
```

Create a modifiable protected model with support for code generation and Web view.

```
Simulink.ModelReference.protect('sldemo_mdref_counter', 'Mode', ...
'CodeGeneration', 'Webview', true, 'Modifiable', true, 'Report', true);
```

Provide the password to modify the protected model.

```
Simulink.ModelReference.ProtectedModel.setPasswordForModify(...
'sldemo_mdref_counter', 'password');
```

Remove support for Web view from the protected model that you created.

```
Simulink.ModelReference.modifyProtectedModel(...
'sldemo_mdref_counter', 'Mode', 'CodeGeneration', 'Report', true);
```

Change Encryption Password for Code Generation

Change an encryption password for a modifiable protected model.

Add the password for when a protected model is modified. If you skip this step, you are prompted to set a password when a modifiable protected model is created.

```
Simulink.ModelReference.ProtectedModel.setPasswordForModify(...
'sldemo_mdref_counter', 'password');
```

Add the password that the protected model user must provide to generate code.

```
Simulink.ModelReference.ProtectedModel.setPasswordForSimulation(...
'sldemo_mdref_counter', 'cgpassword');
```

Create a modifiable protected model with a report and support for code generation with encryption.

```
Simulink.ModelReference.protect('sldemo_mdhref_counter', 'Mode', ...  
'CodeGeneration', 'Encrypt', true, 'Modifiable', true, 'Report', true);
```

Provide the password to modify the protected model.

```
Simulink.ModelReference.ProtectedModel.setPasswordForModify(...  
'sldemo_mdhref_counter', 'password');
```

Change the encryption password for simulation.

```
Simulink.ModelReference.modifyProtectedModel(  
'sldemo_mdhref_counter', 'Mode', 'CodeGeneration', 'Encrypt', true, ...  
'Report', true, 'ChangeSimulationPassword', ...  
{'cgpasword', 'new_password'});
```

Add Harness Model for Protected Model

Add a harness model for an existing protected model.

Add the password for when a protected model is modified. If you skip this step, you are prompted to set a password when a modifiable protected model is created.

```
Simulink.ModelReference.ProtectedModel.setPasswordForModify(...  
'sldemo_mdhref_counter', 'password');
```

Create a modifiable protected model with a report and support for code generation with encryption.

```
Simulink.ModelReference.protect('sldemo_mdhref_counter', 'Mode', ...  
'CodeGeneration', 'Modifiable', true, 'Report', true);
```

Provide the password to modify the protected model.

```
Simulink.ModelReference.ProtectedModel.setPasswordForModify(...  
'sldemo_mdhref_counter', 'password');
```

Add a harness model for the protected model.

```
[harnessHandle] = Simulink.ModelReference.modifyProtectedModel(...  
'sldemo_mdhref_counter', 'Mode', 'CodeGeneration', 'Report', true, ...  
'Harness', true);
```

Input Arguments

model — Model name

string or character vector (default)

Model name, specified as a string or character vector. It contains the name of a model or the path name of a Model block that references the protected model.

Name-Value Pair Arguments

Specify optional comma-separated pairs of **Name**, **Value** arguments. **Name** is the argument name and **Value** is the corresponding value. **Name** must appear inside quotes. You can specify several name and value pair arguments in any order as **Name1**, **Value1**, ..., **NameN**, **ValueN**.

Example: 'Mode', 'CodeGeneration', 'OutputFormat', 'Binaries', 'ObfuscateCode', true specifies that obfuscated code be generated for the protected model. It also specifies that only binary files and headers in the generated code be visible to users of the protected model.

General

Path — Folder for protected model

current working folder (default) | string or character vector

Folder for protected model, specified as a string or character vector.

Example: 'Path', 'C:\Work'

Report — Option to generate a report

false (default) | true

Option to generate a report, specified as a Boolean value.

To view the report, right-click the protected-model badge icon and select **Display Report**. Or, call the `Simulink.ProtectedModel.open` function with the `report` option.

The report is generated in HTML format. It includes information on the environment, functionality, license requirements, and interface for the protected model.

Example: 'Report', true

hdl — Option to generate HDL code

false (default) | true

Option to generate HDL code, specified as a Boolean value.

This option requires HDL Coder license. When you enable this option, make sure that you specify the **Mode**. You can set this option to `true` in conjunction with the **Mode** set to `CodeGeneration` to enable both C code and HDL code generation support for the protected model.

If you want to enable only simulation and HDL code generation support, but not C code generation, set **Mode** to `HDLCodeGeneration`. You do not have to set the **hdl** option to `true`.

Example: 'hdl', true

Harness — Option to create a harness model

false (default) | true

Option to create a harness model, specified as a Boolean value.

Example: 'Harness', true

CustomPostProcessingHook — Option to add postprocessing function for protected model files

function handle

Option to add a postprocessing function for protected model files, specified as a function handle. The function accepts a `Simulink.ModelReference.ProtectedModel.HookInfo` object as an input variable. This object provides information on the source code files and other files generated during protected model creation. The object also provides information on exported symbols that you must not modify. Prior to packaging the protected model, the postprocessing function is called.

For a protected model with a top model interface, the `Simulink.ModelReference.ProtectedModel.HookInfo` object cannot provide information on exported symbols.

Example: `'CustomPostProcessingHook',@(protectedMdlInf)myHook(protectedMdlInf)`

Functionality

Mode — Model protection mode

'Normal' (default) | 'Accelerator' | 'CodeGeneration' | 'HDLCodeGeneration' | 'ViewOnly'

Model protection mode. Specify one of the following values:

- 'Normal': If the top model is running in 'Normal' mode, the protected model runs as a child of the top model.
- 'Accelerator': The top model can run in 'Normal', 'Accelerator', or 'Rapid Accelerator' mode.
- 'CodeGeneration': The top model can run in 'Normal', 'Accelerator', or 'Rapid Accelerator' mode and support code generation.
- 'HDLCodeGeneration': The top model can run in 'Normal', 'Accelerator', or 'Rapid Accelerator' mode and support HDL code generation.
- 'ViewOnly': Turns off Simulate and Generate code functionality modes. Turns on the read-only view mode.

Example: `'Mode', 'Accelerator'`

OutputFormat — Protected code visibility

'CompiledBinaries' (default) | 'MinimalCode' | 'AllReferencedHeaders'

Note This argument affects the output only when you specify `Mode` as 'Accelerator' or 'CodeGeneration'. When you specify `Mode` as 'Normal', only a MEX-file is part of the output package.

Protected code visibility. This argument determines what part of the code generated for a protected model is visible to users. Specify one of the following values:

- 'CompiledBinaries': Only binary files and headers are visible.
- 'MinimalCode': Includes only the minimal header files required to build the code with the chosen build settings. Code in the build folder is visible. Users can inspect the code in the protected model report and recompile it for their purposes.
- 'AllReferencedHeaders': Includes header files found on the include path. Code in the build folder is visible. Header files referenced by the code are also visible.

Example: `'OutputFormat', 'AllReferencedHeaders'`

ObfuscateCode — Option to obfuscate generated code

true (default) | false

Option to obfuscate generated code, specified as a Boolean value. Applicable only when code generation is enabled for the protected model. Obfuscation is not supported for HDL code generation.

Example: 'ObfuscateCode',true

Webview — Option to include a Web view

false (default) | true

Option to include a read-only view of protected model, specified as a Boolean value.

To open the Web view of a protected model, use one of the following methods:

- Right-click the protected-model badge icon and select **Show Web view**.
- Use the `Simulink.ProtectedModel.open` function. For example, to display the Web view for protected model `sldemo_mdhref_counter`, you can call:

```
Simulink.ProtectedModel.open('sldemo_mdhref_counter', 'webview');
```

- Double-click the `.slxp` protected model file in the Current Folder browser.
- In the Block Parameter dialog box for the protected model, click **Open Model**.

Example: 'Webview',true

Encryption

ChangeSimulationPassword — Option to change the encryption password for simulation

cell array of two character vectors

Option to change the encryption password for simulation, specified as a cell array of two character vectors. The first vector is the old password, the second vector is the new password.

Example: 'ChangeSimulationPassword',{'old_password','new_password'}

ChangeViewPassword — Option to change the encryption password for read-only view

cell array of two character vectors

Option to change the encryption password for read-only view, specified as a cell array of two character vectors. The first vector is the old password, the second vector is the new password.

Example: 'ChangeViewPassword',{'old_password','new_password'}

ChangeCodeGenerationPassword — Option to change the encryption password for code generation

cell array of two character vectors

Option to change the encryption password for code generation, specified as a cell array of two character vectors. The first vector is the old password, the second vector is the new password.

Example: 'ChangeCodeGenerationPassword',{'old_password','new_password'}

Encrypt — Option to encrypt protected model

false (default) | true

Option to encrypt a protected model, specified as a Boolean value. Applicable when you have specified a password during protection, or by using the following methods:

- Password for read-only view of model:
`Simulink.ModelReference.ProtectedModel.setPasswordForView`
- Password for simulation:
`Simulink.ModelReference.ProtectedModel.setPasswordForSimulation`

- Password for code generation:
`Simulink.ModelReference.ProtectedModel.setPasswordForCodeGeneration`
- Password for HDL code generation:
`Simulink.ModelReference.ProtectedModel.setPasswordForHDLCodeGeneration`

Example: `'Encrypt',true`

Output Arguments

harnessHandle — Handle of the harness model

double

Handle of the harness model, returned as a double or 0, depending on the value of `Harness`.

If `Harness` is `true`, the value is the handle of the harness model; otherwise, the value is 0.

neededVars — Names of base workspace variables

cell array

Names of base workspace variables used by the protected model, returned as a cell array.

The cell array can also include variables that the protected model does not use.

See Also

`Simulink.ModelReference.ProtectedModel.setPasswordForModify` |
`Simulink.ModelReference.protect`

Introduced in R2014b

Simulink.ModelReference.ProtectedModel.setPasswordForHDLCodeGeneration

Add or provide encryption password for HDL code generation from protected model

Syntax

```
Simulink.ModelReference.ProtectedModel.setPasswordForHDLCodeGeneration(model, password)
```

Description

`Simulink.ModelReference.ProtectedModel.setPasswordForHDLCodeGeneration(model, password)` adds an encryption password for HDL code generation if you create a protected model. If you use a protected model, the function provides the required password to generate code from the model.

Examples

Create a Protected Model with Encryption for HDL Code Generation

Create a protected model with encryption for HDL code generation.

```
Simulink.ModelReference.ProtectedModel.setPasswordForHDLCodeGeneration(...
'hdlcoder_referenced_model_gain', 'password');
Simulink.ModelReference.protect('sldemo_mdhref_counter', ...
'Mode', 'HDLCodeGeneration', 'Encrypt', true, 'Report', true);
```

A protected model named `hdlcoder_referenced_model_gain.slx` is created that requires an encryption password for HDL code generation.

Generate HDL Code from an Encrypted Protected Model

Use a protected model with encryption for HDL code generation.

Provide the encryption password required for HDL code generation from the protected model.

```
Simulink.ModelReference.ProtectedModel.setPasswordForHDLCodeGeneration(...
'hdlcoder_referenced_model_gain', 'password');
```

After you have provided the encryption password, you can generate code from the protected model.

Input Arguments

model — Model name

string or character vector

Model name, specified as a string or character vector. It contains the name of a model or the path name of a Model block that references the protected model.

password — Password for protected model code generation

string or character vector

Password, specified as a string or character vector. If the protected model is encrypted for code generation, the password is required.

See Also

`Simulink.ModelReference.ProtectedModel.setPasswordForCodeGeneration` |
`Simulink.ModelReference.ProtectedModel.setPasswordForSimulation` |
`Simulink.ModelReference.ProtectedModel.setPasswordForView`

Topics

“Create Protected Models to Conceal Contents and Generate HDL Code”

Introduced in R2019a

Simulink.ModelReference.ProtectedModel.setPasswordForModify

Add or provide password for modifying protected model

Syntax

```
Simulink.ModelReference.ProtectedModel.setPasswordForModify(model,password)
```

Description

`Simulink.ModelReference.ProtectedModel.setPasswordForModify(model,password)` adds a password for a modifiable protected model. After the password has been created, the function provides the password for modifying the protected model.

Examples

Add Functionality to Protected Model

Create a modifiable protected model with support for code generation, then modify it to add Web view support.

Add the password for when a protected model is modified. If you skip this step, you are prompted to set a password when a modifiable protected model is created.

```
Simulink.ModelReference.ProtectedModel.setPasswordForModify(...
'sldemo_mdhref_counter','password');
```

Create a modifiable protected model with support for code generation and Web view.

```
Simulink.ModelReference.protect('sldemo_mdhref_counter','Mode',...
'CodeGeneration','Modifiable',true,'Report',true);
```

Provide the password to modify the protected model.

```
Simulink.ModelReference.ProtectedModel.setPasswordForModify(...
'sldemo_mdhref_counter','password');
```

Add support for Web view to the protected model that you created.

```
Simulink.ModelReference.modifyProtectedModel(...
'sldemo_mdhref_counter','Mode','CodeGeneration','Webview',true,...
'Report',true);
```

Input Arguments

model — Model name
string or character vector

Model name, specified as a string or character vector. It contains the name of a model or the path name of a Model block that references the protected model to be modified.

password — Password to modify protected model

string or character vector

Password, specified as a string or character vector. The password is required for modification of the protected model.

See Also

`Simulink.ModelReference.modifyProtectedModel` | `Simulink.ModelReference.protect`

Introduced in R2014b

Simulink.ModelReference.ProtectedModel.setPasswordForSimulation

Add or provide encryption password for simulation of protected model

Syntax

```
Simulink.ModelReference.ProtectedModel.setPasswordForSimulation(model,  
password)
```

Description

`Simulink.ModelReference.ProtectedModel.setPasswordForSimulation(model, password)` adds an encryption password for simulation if you create a protected model. If you use a protected model, the function provides the required password to simulate the model.

Examples

Create a Protected Model with Encryption

Create a protected model with encryption for simulation.

```
Simulink.ModelReference.ProtectedModel.setPasswordForSimulation(...  
'sldemo_mdhref_counter', 'password');  
Simulink.ModelReference.protect('sldemo_mdhref_counter', ...  
'Encrypt', true, 'Report', true);
```

A protected model named `sldemo_mdhref_counter.slxp` is created that requires an encryption password for simulation.

Simulate an Encrypted Protected Model

Use a protected model with encryption for simulation.

Provide the encryption password required for simulation of the protected model.

```
Simulink.ModelReference.ProtectedModel.setPasswordForSimulation(...  
'sldemo_mdhref_counter', 'password');
```

After you have provided the encryption password, you can simulate the protected model.

Input Arguments

model — Model name

string or character vector

Model name, specified as a string or character vector. It contains the name of a model or the path name of a Model block that references the protected model.

password — Password for protected model simulation

string or character vector

Password, specified as a string or character vector. If the protected model is encrypted for simulation, the password is required.

See Also

`Simulink.ModelReference.ProtectedModel.setPasswordForCodeGeneration` |
`Simulink.ModelReference.ProtectedModel.setPasswordForHDLCodeGeneration` |
`Simulink.ModelReference.ProtectedModel.setPasswordForView` |
`Simulink.ModelReference.protect`

Introduced in R2014b

Simulink.ModelReference.ProtectedModel.setPasswordForView

Add or provide encryption password for read-only view of protected model

Syntax

```
Simulink.ModelReference.ProtectedModel.setPasswordForView(model,password)
```

Description

`Simulink.ModelReference.ProtectedModel.setPasswordForView(model,password)` adds an encryption password for read-only view if you create a protected model. If you use a protected model, the function provides the required password for a read-only view of the model.

Examples

Create a Protected Model with Encryption

Create a protected model with encryption for read-only view.

```
Simulink.ModelReference.ProtectedModel.setPasswordForView(...  
'sldemo_mdhref_counter','password');  
Simulink.ModelReference.protect('sldemo_mdhref_counter',...  
'Webview',true,'Encrypt',true,'Report',true);
```

A protected model named `sldemo_mdhref_counter.slxp` is created that requires an encryption password for read-only view.

View an Encrypted Protected Model

Use a protected model with encryption for read-only view.

Provide the encryption password required for the read-only view of the protected model.

```
Simulink.ModelReference.ProtectedModel.setPasswordForView(...  
'sldemo_mdhref_counter','password');
```

After you have provided the encryption password, you have access to the read-only view of the protected model.

Input Arguments

model — Model name

string or character vector

Model name, specified as a string or character vector. It contains the name of a model or the path name of a Model block that references the protected model.

password — Password for read-only view of protected model

string or character vector

Password, specified as a string or character vector. If the protected model is encrypted for read-only view, the password is required.

See Also

`Simulink.ModelReference.ProtectedModel.setPasswordForCodeGeneration` |
`Simulink.ModelReference.ProtectedModel.setPasswordForHDLCodeGeneration` |
`Simulink.ModelReference.ProtectedModel.setPasswordForSimulation` |
`Simulink.ModelReference.protect`

Introduced in R2014b

Simulink.ModelReference.ProtectedModel.clearPasswords

Clear cached passwords for protected models

Syntax

```
Simulink.ModelReference.ProtectedModel.clearPasswords()
```

Description

`Simulink.ModelReference.ProtectedModel.clearPasswords()` clears protected model passwords that have been cached during the current MATLAB session. If this function is not called, cached passwords are cleared at the end of a MATLAB session.

Examples

Clear cached passwords for protected models

After using protected models, clear passwords cached for the models during the MATLAB session.

```
Simulink.ModelReference.ProtectedModel.clearPasswords()
```

See Also

`Simulink.ModelReference.ProtectedModel.clearPasswordsForModel`

Topics

“Protect Models to Conceal Contents” (Simulink Coder)

Introduced in R2014b

Simulink.ModelReference.ProtectedModel.clearPasswordsForModel

Clear cached passwords for a protected model

Syntax

```
Simulink.ModelReference.ProtectedModel.clearPasswordsForModel(model)
```

Description

`Simulink.ModelReference.ProtectedModel.clearPasswordsForModel(model)` clears protected model passwords for `model` that have been cached during the current MATLAB session. If this function is not called, cached passwords are cleared at the end of a MATLAB session.

Examples

Clear cached passwords for a protected model

After using a protected model, clear passwords cached for the model during the MATLAB session.

```
Simulink.ModelReference.ProtectedModel.clearPasswordsForModel(model)
```

Input Arguments

model — Protected model name

string or character vector

Model name specified as a string or character vector

Example: 'rtwdemo_counter'

Data Types: char

See Also

`Simulink.ModelReference.ProtectedModel.clearPasswords`

Topics

"Protect Models to Conceal Contents" (Simulink Coder)

Introduced in R2014b

Simulink.ProtectedModel.open

Open protected model

Syntax

```
Simulink.ProtectedModel.open(model)
Simulink.ProtectedModel.open(model,type)
```

Description

`Simulink.ProtectedModel.open(model)` opens a protected model. If you do not specify how to view the protected model, the software first tries to open the Web view. If the Web view is not enabled for the protected model, the software then tries to open the report. If you did not create a report, the software reports an error.

`Simulink.ProtectedModel.open(model,type)` opens a protected model using the specified viewing method. If you specify 'webview', the software opens the Web view for the protected model. If you specify 'report', the software opens the protected model report. If the method that you specify is not enabled, the software reports an error. The protected model is not opened.

Examples

Open a Protected Model

Open a protected model without a specified method.

Load the model and save a local copy.

```
sldemo_mdhref_counter
save_system('sldemo_mdhref_counter','mdhref_counter.slx');
```

Create a protected model enabling support for code generation and reporting.

```
Simulink.ModelReference.protect('mdhref_counter','Mode',...
'CodeGeneration','Report',true);
```

Open the protected model without specifying how to view it.

```
Simulink.ProtectedModel.open('mdhref_counter')
```

The protected model does not have Web view enabled, so the protected model report is opened.

Open a Protected Model Web View

Open a protected model, specifying the Web view.

Load the model and save a local copy.

```
sldemo_mdref_counter  
save_system('sldemo_mdref_counter','mdlref_counter.slx');
```

Create a protected model with support for code generation, Web view, and reporting.

```
Simulink.ModelReference.protect('mdlref_counter','Mode',...  
'CodeGeneration','Webview',true,'Report',true);
```

Open the protected model and specify that you want to see the Web view.

```
Simulink.ProtectedModel.open('mdlref_counter','webview')
```

The protected model Web view is opened.

Input Arguments

model — Model name

string or character vector

Protected model name, specified as a string or character vector.

type — Open method

'webview' | 'report'

Method for viewing the protected model. If you specify 'webview', the software opens the Web view for the protected model. If you specify 'report', the software opens the protected model report.

See Also

Simulink.ModelReference.protect

Introduced in R2015a

sschdladvisor

Open Simscape HDL Workflow Advisor

Syntax

```
sschdladvisor(subsystem)
sschdladvisor(model)
```

Description

`sschdladvisor(subsystem)` opens the Simscape HDL Workflow Advisor for the subsystem within the model.

`sschdladvisor(model)` opens the Simscape HDL Workflow Advisor for the model.

Examples

Open Simscape HDL Workflow Advisor

This example shows how to open advisor for the model and a subsystem inside a model.

Open Simscape HDL Advisor for a Model

For example: To open the advisor for the Boost Converter model, enter:

```
Modelname = 'sschdlexBoostConverterExample';
open_system(Modelname)
sschdladvisor(Modelname)
```

```
### Running Simscape HDL Workflow Advisor for <a href="matlab:(sschdlexBoostConverterExample)">s
```

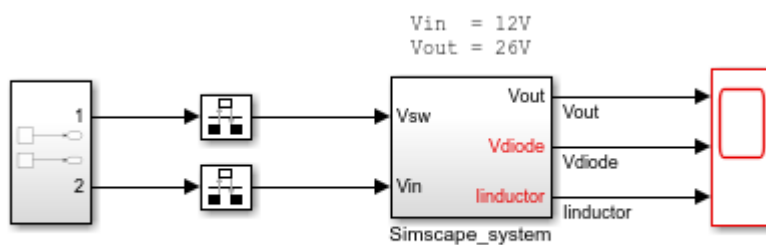

Copyright 2018 The MathWorks, Inc.

Open Simscape HDL Advisor for a Subsystem

For example: To open the advisor for the `Simscape_system` block inside the Buck Converter model, enter:

```
Modelname = 'sschdlexBuckConverterExample';
Subsystemname = 'sschdlexBuckConverterExample/Simscape_system';
```

```
load_system(Modelname)
open_system(Subsysname)
sschdladvisor(Subsysname)
```

```
### Running Simscape HDL Workflow Advisor for <a href="matlab:(sschdlexBuckConverterExample)">ss
```

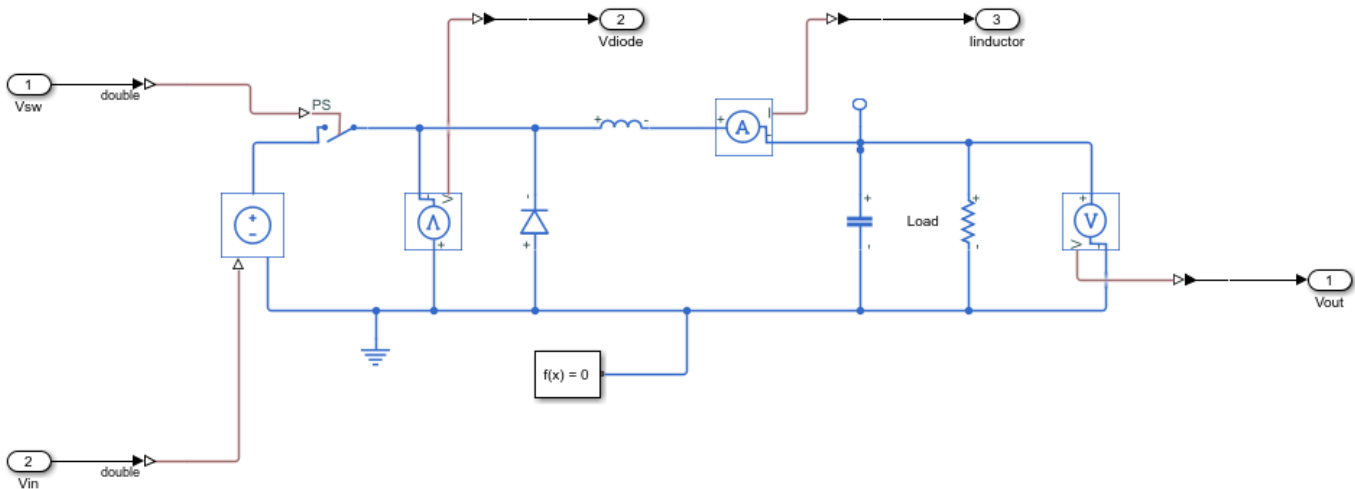

Input Arguments

subsystem – Subsystem name

character vector

Subsystem name or handle, specified as a character vector.

Data Types: char

model – Model name

character vector

Model name or handle, specified as a character vector.

Data Types: char

See Also

`simscape.findNonlinearBlocks`

Topics

“Generate HDL Code for Simscape Models”

Introduced in R2018b

Blocks

Bit Concat

Concatenates up to 128 input words into single output

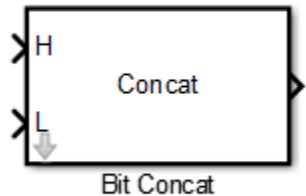

Library

HDL Coder / Logic and Bit Operations

Description

The Bit Concat block concatenates up to 128 input words into a single output. The input port labeled L designates the lowest-order input word. The port labeled H designates the highest-order input word. The right-to-left ordering of words in the output follows the low-to-high ordering of input signals.

How the block operates depends on the number and dimensions of the inputs, as follows:

- Single input: The input is a scalar or a vector. When the input is a vector, the coder concatenates the individual vector elements.
- Two inputs: Inputs are any combination of scalar and vector. When one input is scalar and the other is a vector, the coder performs scalar expansion. Each vector element is concatenated with the scalar, and the output has the same dimension as the vector. When both inputs are vectors, they must have the same size.
- Three or more inputs (up to a maximum of 128 inputs): Inputs are uniformly scalar or vector. All vector inputs must have the same size.

Parameters

Number of Inputs: Enter an integer specifying the number of input signals. The number of block input ports updates when you change **Number of Inputs**.

- Default: 2
- Minimum: 1
- Maximum: 128

Caution Make sure that the **Number of Inputs** is equal to the number of signals you connect to the block. If the block has unconnected inputs, an error occurs at code generation time.

Ports

The block has up to 128 input ports, with H representing the highest-order input word, and L representing the lowest-order input word. The maximum concatenated output word size is 128 bits.

Supported Data Types

- Input: Fixed-point, integer (signed or unsigned), Boolean
- Output: Unsigned fixed-point or integer

Extended Capabilities

HDL Code Generation

Generate Verilog and VHDL code for FPGA and ASIC designs using HDL Coder™.

HDL Coder provides additional configuration options that affect HDL implementation and synthesized logic.

HDL Architecture

This block has a single, default HDL architecture.

HDL Block Properties

General	
ConstrainedOutputPipeline	Number of registers to place at the outputs by moving existing delays within your design. Distributed pipelining does not redistribute these registers. The default is 0. For more details, see "ConstrainedOutputPipeline".
InputPipeline	Number of input pipeline stages to insert in the generated code. Distributed pipelining and constrained output pipelining can move these registers. The default is 0. For more details, see "InputPipeline".
OutputPipeline	Number of output pipeline stages to insert in the generated code. Distributed pipelining and constrained output pipelining can move these registers. The default is 0. For more details, see "OutputPipeline".

See Also

Blocks

Bit Reduce | Bit Rotate | Bit Shift | Bit Slice

Introduced in R2014a

Bit Reduce

AND, OR, or XOR bit reduction on all input signal bits to single bit

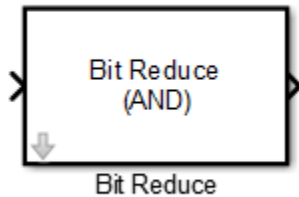

Library

HDL Coder / Logic and Bit Operations

Description

The Bit Reduce block performs a selected bit-reduction operation (AND, OR, or XOR) on all the bits of the input signal, for a single-bit result.

Parameters

Reduction Mode

Specifies the reduction operation:

- AND (default): Perform a bitwise AND reduction of the input signal.
- OR: Perform a bitwise OR reduction of the input signal.
- XOR: Perform a bitwise XOR reduction of the input signal.

Ports

The block has the following ports:

Input

- Supported data types: Fixed-point, integer (signed or unsigned), Boolean
- Minimum bit width: 2
- Maximum bit width: 128

Output

Supported data type: `ufix1`

Extended Capabilities

HDL Code Generation

Generate Verilog and VHDL code for FPGA and ASIC designs using HDL Coder™.

HDL Coder provides additional configuration options that affect HDL implementation and synthesized logic.

HDL Architecture

This block has a single, default HDL architecture.

HDL Block Properties

General	
ConstrainedOutputPipeline	Number of registers to place at the outputs by moving existing delays within your design. Distributed pipelining does not redistribute these registers. The default is 0. For more details, see “ConstrainedOutputPipeline”.
InputPipeline	Number of input pipeline stages to insert in the generated code. Distributed pipelining and constrained output pipelining can move these registers. The default is 0. For more details, see “InputPipeline”.
OutputPipeline	Number of output pipeline stages to insert in the generated code. Distributed pipelining and constrained output pipelining can move these registers. The default is 0. For more details, see “OutputPipeline”.

See Also

Blocks

Bit Concat | Bit Rotate | Bit Shift | Bit Slice

Introduced in R2014a

Bit Rotate

Rotate input signal by bit positions

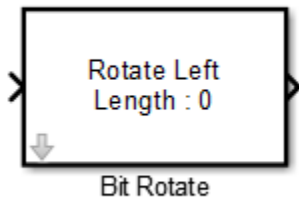

Library

HDL Coder / Logic and Bit Operations

Description

The Bit Rotate block rotates the input signal left or right by the specified number of bit positions.

Parameters

Rotate Mode: Specifies direction of rotation, left or right. The default is `Rotate Left`.

Rotate Length: Specifies the number of bits to rotate. Specify a value greater than or equal to zero. The default is 0.

Ports

The block has the following ports:

Input

- Supported data types: Fixed-point, integer (signed or unsigned), Boolean
- Minimum bit width: 2
- Maximum bit width: 128

Output

Has the same data type as the input signal.

Extended Capabilities

HDL Code Generation

Generate Verilog and VHDL code for FPGA and ASIC designs using HDL Coder™.

HDL Coder provides additional configuration options that affect HDL implementation and synthesized logic.

HDL Architecture

This block has a single, default HDL architecture.

HDL Block Properties

General	
ConstrainedOutputPipeline	Number of registers to place at the outputs by moving existing delays within your design. Distributed pipelining does not redistribute these registers. The default is 0. For more details, see "ConstrainedOutputPipeline".
InputPipeline	Number of input pipeline stages to insert in the generated code. Distributed pipelining and constrained output pipelining can move these registers. The default is 0. For more details, see "InputPipeline".
OutputPipeline	Number of output pipeline stages to insert in the generated code. Distributed pipelining and constrained output pipelining can move these registers. The default is 0. For more details, see "OutputPipeline".

See Also**Blocks**

Bit Concat | Bit Reduce | Bit Shift | Bit Slice

Introduced in R2014a

Bit Shift

Logical or arithmetic shift of input signal

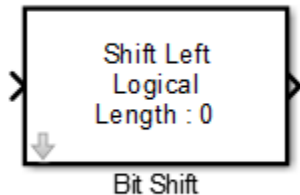

Library

HDL Coder / Logic and Bit Operations

Description

The Bit Shift block performs a logical or arithmetic shift on the input signal.

Parameters

Shift Mode

Default: Shift Left Logical

Specifies the type and direction of shift:

- Shift Left Logical (default)
- Shift Right Logical
- Shift Right Arithmetic

Shift Length

Specifies the number of bits to be shifted. Specify a value greater than or equal to zero. The default is 0.

Ports

The block has the following ports:

Input

- Supported data types: Fixed-point, integer (signed or unsigned), Boolean
- Minimum bit width: 2

- Maximum bit width: 128

Output

Has the same data type and bit width as the input signal.

Extended Capabilities

HDL Code Generation

Generate Verilog and VHDL code for FPGA and ASIC designs using HDL Coder™.

HDL Coder provides additional configuration options that affect HDL implementation and synthesized logic.

HDL Architecture

This block has a single, default HDL architecture.

HDL Block Properties

General	
ConstrainedOutputPipeline	Number of registers to place at the outputs by moving existing delays within your design. Distributed pipelining does not redistribute these registers. The default is 0. For more details, see “ConstrainedOutputPipeline”.
InputPipeline	Number of input pipeline stages to insert in the generated code. Distributed pipelining and constrained output pipelining can move these registers. The default is 0. For more details, see “InputPipeline”.
OutputPipeline	Number of output pipeline stages to insert in the generated code. Distributed pipelining and constrained output pipelining can move these registers. The default is 0. For more details, see “OutputPipeline”.

See Also

Blocks

Bit Concat | Bit Reduce | Bit Rotate | Bit Slice

Introduced in R2014a

Bit Slice

Return field of consecutive bits from input signal

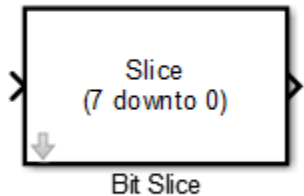

Library

HDL Coder / Logic and Bit Operations

Description

The Bit Slice block returns a field of consecutive bits from the input signal. Specify the lower and upper boundaries of the bit field by using zero-based indices in the **LSB Position** and **MSB Position** parameters.

Parameters

MSB Position

Specifies the bit position (zero-based) of the most significant bit (MSB) of the field to extract. The default is 7.

For an input word size *WS*, **LSB Position** and **MSB Position** must satisfy the following constraints:

```
WS > MSB Position >= LSB Position >= 0;
```

The word length of the output is computed as $(\text{MSB Position} - \text{LSB Position}) + 1$.

LSB Position

Specifies the bit position (zero-based) of the least significant bit (LSB) of the field to extract. The default is 0.

Ports

The block has the following ports:

Input

- Supported data types: Fixed-point, integer (signed or unsigned), Boolean
- Maximum bit width: 128

Output

Supported data types: unsigned fixed-point or unsigned integer.

Extended Capabilities

HDL Code Generation

Generate Verilog and VHDL code for FPGA and ASIC designs using HDL Coder™.

HDL Coder provides additional configuration options that affect HDL implementation and synthesized logic.

HDL Architecture

This block has a single, default HDL architecture.

HDL Block Properties

General	
ConstrainedOutputPipeline	Number of registers to place at the outputs by moving existing delays within your design. Distributed pipelining does not redistribute these registers. The default is 0. For more details, see "ConstrainedOutputPipeline".
InputPipeline	Number of input pipeline stages to insert in the generated code. Distributed pipelining and constrained output pipelining can move these registers. The default is 0. For more details, see "InputPipeline".
OutputPipeline	Number of output pipeline stages to insert in the generated code. Distributed pipelining and constrained output pipelining can move these registers. The default is 0. For more details, see "OutputPipeline".

See Also

Blocks

Bit Concat | Bit Reduce | Bit Rotate | Bit Shift

Introduced in R2014a

Cosine HDL Optimized

Implement fixed-point cosine wave optimized for HDL code generation

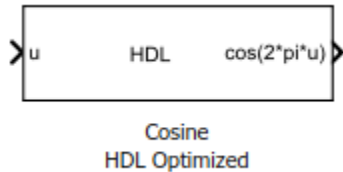

Library

HDL Coder / Lookup Tables

Description

The Cosine HDL Optimized block implements a fixed-point cosine wave by using a lookup table method that exploits quarter-wave symmetry.

For the most efficient HDL implementation, configure the block with an exact power of two as the number of elements. In the Block Parameters dialog box, for **Number of data points**, specify an integer that is an exact power of two. That is, specify the lookup table data points to be (2^n) , where n is an integer. By default, the **Number of data points** is 64.

When you specify a power of two for the **Number of data points**, the lookup tables precede a register without reset after HDL code generation. The combination of the lookup table block and register without reset maps efficiently to RAM on the target device.

Depending on your selection of the **Output formula** parameter, the blocks can output these functions of the input signal:

- $\sin(2\pi u)$
- $\cos(2\pi u)$
- $\exp(i2\pi u)$
- $\sin(2\pi u)$ and $\cos(2\pi u)$

Use the **Table data type** parameter to specify the word length of the fixed-point output data type. The fraction length of the output is the output word length minus 2.

Data Type Support

The Cosine HDL Optimized block accepts signals of these data types:

- Floating point
- Built-in integer
- Fixed point

- Boolean

The output of the block is a fixed-point data type.

For more information, see “Data Types Supported by Simulink” (Simulink) in the Simulink documentation.

Parameters

Output formula

Select the signal(s) to output.

Number of data points

Specify the number of data points to retrieve from the lookup table. The implementation is most efficient when you specify the lookup table data points to be (2^n) , where n is an integer.

Table data type

Specify the table data type. You can specify an expression that evaluates to a data type, for example, `fixdt(1,16,0)`.

Click the **Show data type assistant** button  to display the **Data Type Assistant**, which helps you set the table data type.

Show data type assistant

Select the mode of data type specification. If you select **Expression**, enter an expression that evaluates to a data type, for example, `fixdt(1,16,0)`.

If you select **Fixed point**, you can use the options in the **Data Type Assistant** to specify the fixed-point data type. In the **Fixed point** mode, you can choose binary point scaling, and specify the signedness, word length, fraction length, and the data type override setting.

Characteristics

Data Types	Double Single Boolean Base Integer Fixed-Point
Sample Time	Inherited from driving block
Direct Feedthrough	Yes
Multidimensional Signals	No
Variable-Size Signals	No
Zero-Crossing Detection	No
Code Generation	Yes

Extended Capabilities

HDL Code Generation

Generate Verilog and VHDL code for FPGA and ASIC designs using HDL Coder™.

HDL Coder provides additional configuration options that affect HDL implementation and synthesized logic.

HDL Architecture

The HDL code implements the Cosine HDL Optimized block by using the quarter-wave lookup table that you specify in the Simulink block parameters.

HDL Block Properties

General	
ConstrainedOutputPipeline	Number of registers to place at the outputs by moving existing delays within your design. Distributed pipelining does not redistribute these registers. The default is 0. For more details, see "ConstrainedOutputPipeline".
InputPipeline	Number of input pipeline stages to insert in the generated code. Distributed pipelining and constrained output pipelining can move these registers. The default is 0. For more details, see "InputPipeline".
OutputPipeline	Number of output pipeline stages to insert in the generated code. Distributed pipelining and constrained output pipelining can move these registers. The default is 0. For more details, see "OutputPipeline".

See Also

Blocks

Sine HDL Optimized | Sine, Cosine | Trigonometric Function

Introduced in R2016b

Deserializer1D

Convert scalar stream or smaller vectors to vector signal

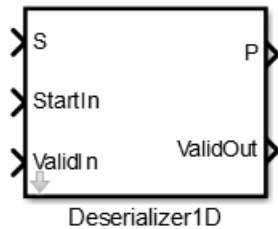

Library

HDL Coder / HDL Operations

Description

The Deserializer1D block buffers a faster, scalar stream or vector signals into a larger, slower vector signal. The faster input signal is converted to a slower signal based on the **Ratio** and **Idle Cycle** values, the conversion changes sample time. Also, the output signal is delayed one slow signal cycle because the serialized data needs to be collected before it can be output as a vector. See the examples below for more details.

You can configure the deserialization to depend on a valid input signal ValidIn and a start signal StartIn. If the **ValidIn** and **StartIn** block parameters are both selected, data collection starts only if both ValidIn and StartIn signals are true. Consider this example:

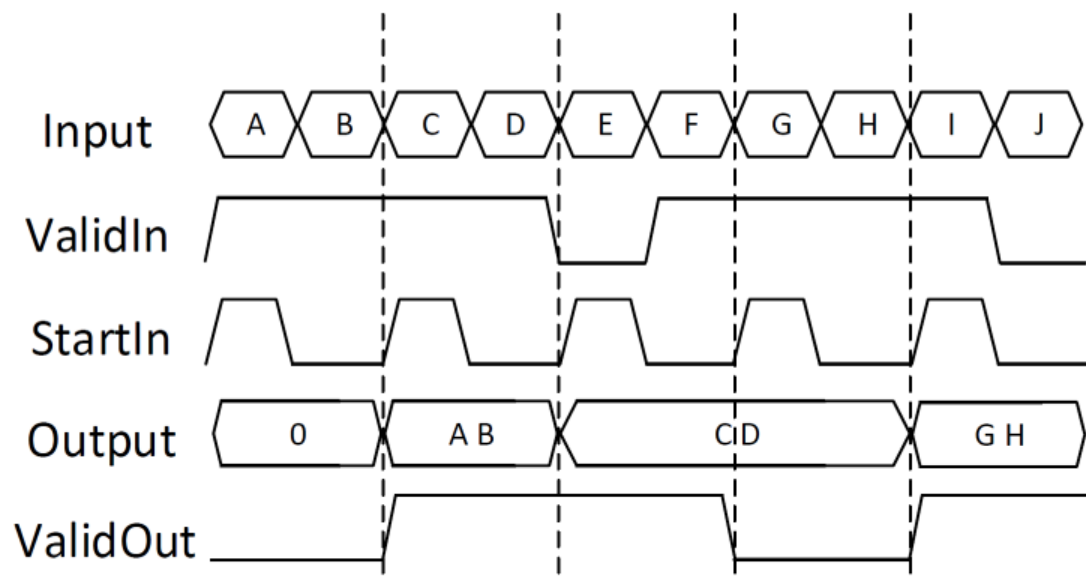

- **Ratio** is 2 and **Idle Cycles** is 0, so each output cycle is two input signals long with all data points considered.

- **ValidIn** and **StartIn** are selected, so data collection can begin only when both StartIn and ValidIn signals are true.
- **ValidOut** is selected.

In the first cycle, ValidIn and StartIn are true, so data collection begins for A and B. The block outputs the deserialized vector in the next valid cycle, so the AB vector is output in the next cycle. This is also true in the second cycle for C and D.

In the third cycle, starting at E, StartIn is true, but ValidIn is not. E is dropped. At F, ValidIn is true, but StartIn is not, so F is also dropped. Since it cannot collect data for E or F, Deserializer1D outputs the previous cycle vector, CD, but ValidOut changes to false.

Another scenario to consider is when the StartIn signal arrives too early. If the length between two StartIn signals is not long enough to collect a full ratio cycle, the insufficient signal data is dropped. Consider this example:

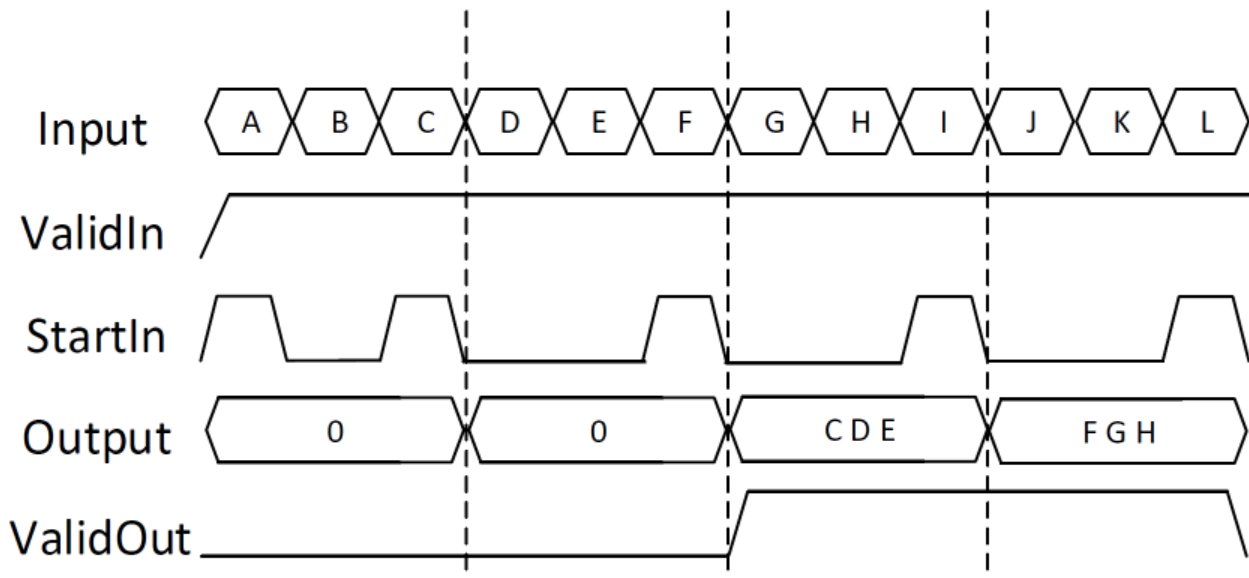

- **Ratio** is 3, so each cycle is two sections long.
- **Idle Cycles** is 0, so all data inputs are considered.
- **ValidIn** and **StartIn** are selected, so data collection can begin only when both StartIn and ValidIn signals are true.
- **ValidOut** is selected.

In the first cycle, ValidIn and StartIn are true, so data collection can begin for A and B. However, at C another StartIn signal arrives before three signals can be collected. Because the StartIn arrived early, A and B are dropped and no valid vector is collected during the first cycle. Therefore, the output of the second cycle is still zero. Deserialization begins at the StartIn at C, for C, D, and E. This vector is output at the next valid cycle, which is cycle 3. Similarly, deserialization starts again at the StartIn at F, and outputs the FGH vector in the fourth cycle.

You specify the block output for the first sampling period with the value of the **Initial condition** parameter.

Parameters

Ratio

Enter the deserialization ratio. Default is 1.

The ratio is the output vector size, divided by the input vector size. The ratio must be divisible by the input vector size.

Idle Cycles

Enter the number of idle cycles added to the end of each serialized input. Default is 0.

The value of **Idle Cycles** affects the deserialized output rate. For example, if **Ratio** is 2 and the input signal is A, B, B, C, D, D, . . ., without idle cycles the output would be AB, BC, DD. . . . However for the same input and ratio with **Idle Cycles** set to 1, the output is AB, CD. . . . The idle cycles, B and D, are dropped.

The Deserializer1D behavior changes if **Idle Cycles** is not zero, and **ValidIn** or **StartIn** are on. The idle cycles value affects only the output rate, while **ValidIn** and **StartIn** control what input data is deserialized.

Initial condition

Specify the initial output of the simulation. Default is 0.

StartIn

Select to activate the StartIn port. Default is off.

ValidIn

Select to activate the ValidIn port. Default is off.

ValidOut

Select to activate ValidOut port. Default is off.

Input data port dimensions (-1 for inherited)

Enter the size of the input data signal. The input size must be divisible by the ratio plus the number of idle cycles. By default, the block inherits size based on context within the model.

Input sample time (-1 for inherited)

Enter the time interval between sample time hits or specify another appropriate sample time such as continuous. By default, the block inherits its sample time based on context within the model. For more information, see "Sample Time" (Simulink).

Input signal type

Specify the input signal type of the block as auto, real, or complex.

Ports

S

Input signal to deserialize. Bus data types are not supported.

ValidIn

Indicates valid input signal. Use with the Serializer1D block. This port is available when you select the **ValidIn** check box.

Data type: Boolean

StartOut

Indicates where to start deserialization. Use with the Serializer1D block. This port is available when you select the **StartOut** check box.

Data type: Boolean

P

Deserialized output signal. Bus data types are not supported.

ValidOut

Indicates valid output signal. This port is available when you select the **ValidOut** check box.

Data type: Boolean

Extended Capabilities

HDL Code Generation

Generate Verilog and VHDL code for FPGA and ASIC designs using HDL Coder™.

HDL Coder provides additional configuration options that affect HDL implementation and synthesized logic.

HDL Architecture

Note For simulation results that match the generated HDL code, in the Solver pane of the Configuration Parameters dialog box, clear the checkbox for **Treat each discrete rate as a separate task**. When the checkbox is cleared, single-tasking mode is enabled. If you simulate the block with this check box selected, the output data can update in the same cycle but in the generated HDL code, the output data is updated one cycle later.

This block has a single, default HDL architecture.

HDL Block Properties

General	
ConstrainedOutputPipeline	Number of registers to place at the outputs by moving existing delays within your design. Distributed pipelining does not redistribute these registers. The default is 0. For more details, see "ConstrainedOutputPipeline".
InputPipeline	Number of input pipeline stages to insert in the generated code. Distributed pipelining and constrained output pipelining can move these registers. The default is 0. For more details, see "InputPipeline".
OutputPipeline	Number of output pipeline stages to insert in the generated code. Distributed pipelining and constrained output pipelining can move these registers. The default is 0. For more details, see "OutputPipeline".

See Also

Serializer1D

Introduced in R2014b

Dual Port RAM

Dual port RAM with two output ports

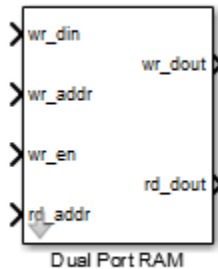

Library

HDL Coder / HDL RAMs

Description

The Dual Port RAM block models a RAM that supports simultaneous read and write operations, and has both a read data output port and write data output port. You can use this block to generate HDL code that maps to RAM in most FPGAs.

If you do not need to use the write output data, `wr_dout`, you can achieve better RAM inference with synthesis tools by using the Simple Dual Port RAM block.

Read-During-Write Behavior

During a write, new data appears at the output of the write port (`wr_dout`) of the Dual Port RAM block. If a read operation occurs simultaneously at the same address as a write operation, old data appears at the read output port (`rd_dout`).

Parameters

Address port width

Address bit width. Minimum bit width is 2, and maximum bit width is 29. The default is 8.

Ports

The block has the following ports:

`wr_din`

Write data input. The data can be any width. It inherits the width and data type from the input signal.

Data type: scalar fixed point, integer, or complex

wr_addr

Write address.

Data type: scalar unsigned integer (`uintN`) or unsigned fixed point (`ufixN`) with a fraction length of 0

wr_en

Write enable.

Data type: Boolean

rd_addr

Read address.

Data type: scalar unsigned integer (`uintN`) or unsigned fixed point (`ufixN`) with a fraction length of 0

wr_dout

Output data from write address, `wr_addr`.

rd_dout

Output data from read address, `rd_addr`.

Algorithms

HDL code generated for RAM blocks has:

- A latency of one clock cycle for read data output.
- No reset signal, because some synthesis tools do not infer a RAM from HDL code if it includes a reset.

Code generation for a RAM block creates a separate file, *blockname.ext*. *blockname* is derived from the name of the RAM block. *ext* is the target language file name extension.

RAM Initialization

Code generated to initialize a RAM is intended for simulation only. Synthesis tools can ignore this code.

Implement RAM With or Without Clock Enable

The HDL block property, `RAMArchitecture`, enables or suppresses generation of clock enable logic for all RAM blocks in a subsystem. You can set `RAMArchitecture` to the following values:

- `WithClockEnable` (default): Generates RAMs using HDL templates that include a clock enable signal, and an empty RAM wrapper.
- `WithoutClockEnable`: Generates RAMs without clock enables, and a RAM wrapper that implements the clock enable logic.

Some synthesis tools do not infer RAMs with a clock enable. If your synthesis tool does not support RAM structures with a clock enable, and cannot map your generated HDL code to FPGA RAM resources, set `RAMArchitecture` to `'WithoutClockEnable'`. To learn how to generate RAMs without clock enables for your design, see the Getting Started with RAM and ROM example. To open the example, at the command prompt, enter:

hdlcoderramrom

RAM Inference Limitations

If you use RAM blocks to perform concurrent read and write operations, verify the read-during-write behavior in hardware. The read-during-write behavior of the RAM blocks in Simulink matches that of the generated behavioral HDL code. However, if a synthesis tool does not follow the same behavior during RAM inference, it causes the read-during-write behavior in hardware to differ from the behavior of the Simulink model or generated HDL code.

Your synthesis tool might not map the generated code to RAM for the following reasons:

- Small RAM size: your synthesis tool uses registers to implement a small RAM for better performance.
- A clock enable signal is present. You can suppress generation of a clock enable signal in RAM blocks, as described in “Implement RAM With or Without Clock Enable” on page 3-21.

Extended Capabilities

HDL Code Generation

Generate Verilog and VHDL code for FPGA and ASIC designs using HDL Coder™.

HDL Coder provides additional configuration options that affect HDL implementation and synthesized logic.

HDL Architecture

This block has a single, default HDL architecture.

HDL Block Properties

General	
ConstrainedOutputPipeline	Number of registers to place at the outputs by moving existing delays within your design. Distributed pipelining does not redistribute these registers. The default is 0. For more details, see “ConstrainedOutputPipeline”.
InputPipeline	Number of input pipeline stages to insert in the generated code. Distributed pipelining and constrained output pipelining can move these registers. The default is 0. For more details, see “InputPipeline”.
OutputPipeline	Number of output pipeline stages to insert in the generated code. Distributed pipelining and constrained output pipelining can move these registers. The default is 0. For more details, see “OutputPipeline”.
RAMDirective	Specify whether to map the RAM blocks in your design to distributed RAMs or block RAMs on the target FPGA. You cannot map Dual Port RAM blocks to UltraRAM. Mapping to UltraRAM requires the block to have a fixed read behavior.

Complex Data Support

This block supports code generation for complex signals.

See Also

Blocks

Dual Rate Dual Port RAM | Simple Dual Port RAM | Single Port RAM

Introduced in R2014a

Dual Port RAM System

Dual Port RAM block based on the `hdl.RAM` system object with ability to provide initial value

Library: HDL Coder / HDL RAMs

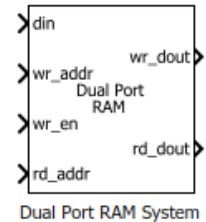

Description

The blocks are MATLAB System blocks that use the `hdl.RAM System` object™. You can specify the RAM type as `Dual port`, `Simple dual port`, or `Single port`. In terms of simulation behavior, the Dual Port RAM System block behaves similar to the Dual Port RAM, the Single Port RAM System behaves similar to the Single Port RAM, and so on. With the MATLAB System blocks, you can:

- Specify an initial value for the RAM. In the Block Parameters dialog box, enter a value for **Specify the RAM initial value**.
- Obtain faster simulation results when you use these blocks in your Simulink model.
- Create parallel RAM banks when you use vector data by leveraging the `hdl.RAM System` object functionality.
- Obtain higher performance and support for large data memories.

Limitations

- The block does not support boolean inputs. Cast any boolean types to `ufix1` for input to the block.
- When you build the FPGA bitstream for the RAM, the global reset logic does not reset the RAM contents. To reset the RAM, make sure that you implement the reset logic.
- The RAM write address can be either `fixed-point (fi)` or `integer`, must be unsigned, and must be between 2 and 31 bits long.

Ports

Input

din — Write data input

Scalar (default) | Vector

Data that you write into the RAM memory location when `wrEn` is true. This value can be `double`, `single`, `integer`, or a `fixed-point (fi)` object, and can be real or complex.

Data Types: `single` | `double` | `int8` | `int16` | `uint8` | `uint16` | `fixed point`

wr_addr — Write address

Scalar (default) | Vector

RAM address that you write the data into. This value can be either `fixed-point (fi)` or `integer`, must be unsigned, and must be between 2 and 31 bits long.

Dependencies

To enable this port, set the **Specify the type of RAM** parameter to `Simple dual port` or `Dual port`.

Data Types: `uint8` | `uint16` | `fixed point`

wr_en — Write enable

Scalar (default) | Vector

When `wrEn` is true, the RAM writes the data into the memory location that you specify. If you set the **Specify the type of RAM** to `Single port`, the RAM reads the value in the memory location `addr` when `wrEn` is false.

Data Types: `Boolean`

rd_addr — Read address

Scalar (default) | Vector

Address that you read the data from the RAM. This value can be either `fixed-point (fi)` or `integer`, and must be real and unsigned.

Dependencies

To enable this port, set the **Specify the type of RAM** parameter to `Simple dual port` or `Dual port`.

Data Types: `uint8` | `uint16` | `fixed point`

Output

rd_dout — Read data

Scalar (default) | Vector

Old output data that the RAM reads from the memory location `rd_addr`.

Dependencies

To enable this port, set the **Specify the type of RAM** parameter to `Simple dual port` or `Dual port`.

wr_dout — Write data output

Scalar (default) | Vector

New or old output data that the RAM reads from the memory location `wr_addr`.

Dependencies

To enable this port, set the **Specify the type of RAM** parameter to `Dual port`.

Parameters

Specify the type of RAM — RAM type

`Dual port` (default) | `Simple dual port` | `Single port`

Type of RAM, specified as either:

- **Single port** — Create a single port RAM with Write data, Address, and Write enable as inputs and Read data as the output.
- **Simple dual port** — Create a simple dual port RAM with Write data, Write address, Write enable, and Read address as inputs and data from read address as the output.
- **Dual port** — Create a dual port RAM with Write data, Write address, Write enable, and Read address as inputs and data from read address and write address as the outputs.

The code generator dynamically configures the input and output ports of the block based on the RAM type that you specify.

Specify the output data for a write operation — Write output behavior

New data (default) | Old data

Behavior for Write output, specified as either:

- 'New data' — Send out new data at the address to the output.
- 'Old data' — Send out old data at the address to the output.

Specify the RAM initial value — Initial simulation output of RAM

'0.0' (default) | Scalar | Vector

Initial simulation output of the System object, specified as either:

- A scalar value.
- A vector with one-to-one mapping between the initial value and the RAM words.

Extended Capabilities

HDL Code Generation

Generate Verilog and VHDL code for FPGA and ASIC designs using HDL Coder™.

HDL Architecture

The block has a MATLABSystem architecture which indicates that the block implementation uses the `hdl.RAM` System object.

HDL Block Properties

General	
ConstrainedOutputPipeline	Number of registers to place at the outputs by moving existing delays within your design. Distributed pipelining does not redistribute these registers. The default is 0. For more details, see "ConstrainedOutputPipeline".
InputPipeline	Number of input pipeline stages to insert in the generated code. Distributed pipelining and constrained output pipelining can move these registers. The default is 0. For more details, see "InputPipeline".
OutputPipeline	Number of output pipeline stages to insert in the generated code. Distributed pipelining and constrained output pipelining can move these registers. The default is 0. For more details, see "OutputPipeline".

General	
RAMDirective	Specify whether to map RAM blocks in your design to distributed RAMs, block RAMs, or UltraRAM memory on the target FPGA. For UltraRAM mapping, Specify the RAM initial value must be set to 0. See also "RAMDirective".

Complex Data Support

This block supports code generation for complex signals.

See Also

System Objects

hdl.RAM

Blocks

Simple Dual Port RAM System | Single Port RAM System

Topics

"HDL Code Generation from hdl.RAM System Object"

"Getting Started with RAM and ROM in Simulink®"

"Implement RAM Using MATLAB Code"

"HDL Code Generation for System Objects"

Introduced in R2017b

Dual Rate Dual Port RAM

Dual Port RAM that supports two rates

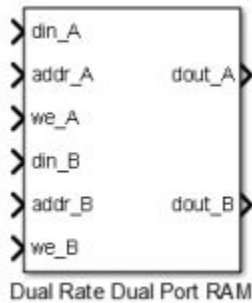

Library

HDL Coder / HDL RAMs

Description

The Dual Rate Dual Port RAM block models a RAM that supports simultaneous read and write operations to different addresses at two clock rates. Port A of the RAM can run at one rate, and port B can run at a different rate.

In high-performance hardware applications, you can use this block to access the RAM twice per clock cycle. If you generate HDL code, this block maps to a dual-clock dual-port RAM in most FPGAs.

Simultaneous Access

You can access different addresses from ports A and B simultaneously. You can also read the same address from ports A and B simultaneously.

However, do not access an address from one RAM port while it is being written from the other RAM port. During simulation, if you access an address from one RAM port at the same time as you write that address from the other RAM port, the software reports an error.

Read-During-Write Behavior

The RAM has write-first behavior. When you write to the RAM, the new write data is immediately available at the output port.

Parameters

Address port width

Address bit width. Minimum bit width is 2, and maximum bit width is 28. The default value is 8.

Ports

The block has the following ports:

din_A

Write data input for RAM port A. The data can be any width. It inherits the width and data type from the input signal.

Data type: scalar fixed point, integer, or complex

addr_A

Write address for RAM port A.

Data type: scalar unsigned integer (`uintN`) or unsigned fixed point (`ufixN`) with a fraction length of 0

we_A

Write enable for RAM port A. Set `we_A` to `true` for a write operation, or `false` for a read operation.

Data type: Boolean

din_B

Write data input for RAM port B. The data can be of any width, and inherits the width and data type from the input signal.

Data type: scalar fixed point, integer, or complex

addr_B

Write address for RAM port B.

Data type: scalar unsigned integer (`uintN`) or unsigned fixed point (`ufixN`) with a fraction length of 0

we_B

Write enable for RAM port B. Set `we_B` to `true` for a write operation, or `false` for a read operation.

Data type: Boolean

dout_A

Output data from RAM port A address, `addr_A`.

dout_B

Output data from RAM port B address, `addr_B`.

Algorithms

HDL code generated for RAM blocks has:

- A latency of one clock cycle for read data output.
- No reset signal, because some synthesis tools do not infer a RAM from HDL code if it includes a reset.

Code generation for a RAM block creates a separate file, *blockname.ext*. *blockname* is derived from the name of the RAM block. *ext* is the target language file name extension.

RAM Initialization

Code generated to initialize a RAM is intended for simulation only. Synthesis tools can ignore this code.

Implement RAM With or Without Clock Enable

The HDL block property, `RAMArchitecture`, enables or suppresses generation of clock enable logic for all RAM blocks in a subsystem. You can set `RAMArchitecture` to the following values:

- `WithClockEnable` (default): Generates RAM using HDL templates that include a clock enable signal, and an empty RAM wrapper.
- `WithoutClockEnable`: Generates RAM without clock enables, and a RAM wrapper that implements the clock enable logic.

Some synthesis tools do not infer RAM with a clock enable. If your synthesis tool does not support RAM structures with a clock enable, and cannot map your generated HDL code to FPGA RAM resources, set `RAMArchitecture` to `WithoutClockEnable`.

RAM Inference Limitations

If you use RAM blocks to perform concurrent read and write operations, verify the read-during-write behavior in hardware. The read-during-write behavior of the RAM blocks in Simulink matches that of the generated behavioral HDL code. However, if a synthesis tool does not follow the same behavior during RAM inference, it causes the read-during-write behavior in hardware to differ from the behavior of the Simulink model or generated HDL code.

Your synthesis tool might not map the generated code to RAM for the following reasons:

- Small RAM size: your synthesis tool uses registers to implement a small RAM for better performance.
- A clock enable signal is present. You can suppress generation of a clock enable signal in RAM blocks, as described in “Implement RAM With or Without Clock Enable” on page 3-30.

Extended Capabilities

HDL Code Generation

Generate Verilog and VHDL code for FPGA and ASIC designs using HDL Coder™.

HDL Coder provides additional configuration options that affect HDL implementation and synthesized logic.

HDL Architecture

Note For simulation results that match the generated HDL code, in the Solver pane of the Configuration Parameters dialog box, clear the checkbox for **Treat each discrete rate as a separate task**. When the checkbox is cleared, single-tasking mode is enabled. If you simulate the block with this check box selected, the output data can update in the same cycle but in the generated HDL code, the output data is updated one cycle later.

This block has a single, default HDL architecture.

HDL Block Properties

General	
ConstrainedOutputPipeline	Number of registers to place at the outputs by moving existing delays within your design. Distributed pipelining does not redistribute these registers. The default is 0. For more details, see “ConstrainedOutputPipeline”.
InputPipeline	Number of input pipeline stages to insert in the generated code. Distributed pipelining and constrained output pipelining can move these registers. The default is 0. For more details, see “InputPipeline”.
OutputPipeline	Number of output pipeline stages to insert in the generated code. Distributed pipelining and constrained output pipelining can move these registers. The default is 0. For more details, see “OutputPipeline”.

Note The **RAMDirective** property is not available for use with the Dual Rate Dual Port RAM because the block does not have a single clock interface.

Complex Data Support

This block supports code generation for complex signals. You cannot have mixed real-value and complex inputs.

See Also

Blocks

Dual Port RAM | Simple Dual Port RAM | Single Port RAM

Introduced in R2014a

Enabled Synchronous Subsystem

Represent enabled subsystem that has synchronous reset and enable behavior



Library

HDL Coder / HDL Subsystems

Description

An Enabled Synchronous Subsystem is an Enabled Subsystem that uses the **Synchronous** mode of the State Control block. If an **S** symbol appears in the subsystem, then it is synchronous.

To create an Enabled Synchronous Subsystem block, add the block to your Simulink model from the HDL Subsystems block library. You can also add a State Control block with **State control** set to **Synchronous** inside an Enabled subsystem.

For more information, see State Control and “Using Enabled Subsystems” (Simulink).

Data Type Support

See Inport for information on the data types accepted by a subsystem's input ports. See Outport for information on the data types output by a subsystem's output ports.

For more information, see “Data Types Supported by Simulink” (Simulink) in the Simulink documentation.

Parameters

Show port labels

Cause Simulink software to display labels for the subsystem's ports on the subsystem's icon.

Settings

Default: FromPortIcon

none

Does not display port labels on the subsystem block.

FromPortIcon

If the corresponding port icon displays a signal name, display the signal name on the subsystem block. Otherwise, display the port block's name.

FromPortBlockName

Display the name of the corresponding port block on the subsystem block.

SignalName

If a name exists, display the name of the signal connected to the port on the subsystem block; otherwise, the name of the corresponding port block.

Command-Line Information

See “Block-Specific Parameters” (Simulink) for the command-line information.

Read/Write permissions

Control user access to the contents of the subsystem.

Settings**Default:** ReadWrite**ReadWrite**

Enables opening and modification of subsystem contents.

ReadOnly

Enables opening but not modification of the subsystem. If the subsystem resides in a block library, you can create and open links to the subsystem and can make and modify local copies of the subsystem but cannot change the permissions or modify the contents of the original library instance.

NoReadOrWrite

Disables opening or modification of subsystem. If the subsystem resides in a library, you can create links to the subsystem in a model but cannot open, modify, change permissions, or create local copies of the subsystem.

Command-Line Information

See “Block-Specific Parameters” (Simulink) for the command-line information.

Name of error callback function

Enter name of a function to be called if an error occurs while Simulink software is executing the subsystem.

Settings**Default:** ' '

Simulink software passes two arguments to the function: the handle of the subsystem and a character vector that specifies the error type. If no function is specified, Simulink software displays a generic error message if executing the subsystem causes an error.

Command-Line Information

See “Block-Specific Parameters” (Simulink) for the command-line information.

Permit hierarchical resolution

Specify whether to resolve names of workspace variables referenced by this subsystem.

Settings**Default:** All

All

Resolve all names of workspace variables used by this subsystem, including those used to specify block parameter values and Simulink data objects (for example, `Simulink.Signal` objects).

ExplicitOnly

Resolve only names of workspace variables used to specify block parameter values, data store memory (where no block exists), signals, and states marked as “must resolve”.

None

Do not resolve workspace variable names.

Command-Line Information

See “Block-Specific Parameters” (Simulink) for the command-line information.

Treat as atomic unit

Causes Simulink software to treat the subsystem as a unit when determining the execution order of block methods.

Settings

Default: Off

On

Cause Simulink software to treat the subsystem as a unit when determining the execution order of block methods. For example, when it needs to compute the output of the subsystem, Simulink software invokes the output methods of all the blocks in the subsystem before invoking the output methods of other blocks at the same level as the subsystem block.

Off

Cause Simulink software to treat all blocks in the subsystem as being at the same level in the model hierarchy as the subsystem when determining block method execution order. This can cause execution of methods of blocks in the subsystem to be interleaved with execution of methods of blocks outside the subsystem.

Dependencies

This parameter enables:

- **Minimize algebraic loop occurrences**
- **Sample time**
- **Function packaging** (requires a Simulink Coder license)

Command-Line Information

See “Block-Specific Parameters” (Simulink) for the command-line information.

Treat as grouped when propagating variant conditions

Causes Simulink software to treat the subsystem as a unit when propagating variant conditions from Variant Source blocks or to Variant Sink blocks.

Settings

Default: On

On

Simulink treats the subsystem as a unit when propagating variant conditions from Variant Source blocks or to Variant Sink blocks. For example, when Simulink computes the variant condition of the subsystem, it propagates that condition to all the blocks in the subsystem.

Off

Simulink treats all blocks in the subsystem as being at the same level in the model hierarchy as the subsystem itself when determining their variant condition.

Dependency

Treat as grouped when propagating variant conditions enables this parameter.

Command-Line Information

See “Block-Specific Parameters” (Simulink) for the command-line information.

Function packaging

Specify the code format to be generated for an atomic (nonvirtual) subsystem.

Settings

Default: Auto

Auto

Simulink Coder software chooses the optimal format for you based on the type and number of instances of the subsystem that exist in the model.

Inline

Simulink Coder software inlines the subsystem unconditionally.

Nonreusable function

Simulink Coder software explicitly generates a separate function in a separate file. Subsystems with this setting generate functions that might have arguments depending on the **Function interface** parameter setting. You can name the generated function and file using parameters **Function name** and **File name (no extension)**. These functions are not reentrant.

Reusable function

Simulink Coder software generates a function with arguments that allows reuse of subsystem code when a model includes multiple instances of the subsystem.

This option also generates a function with arguments that allows subsystem code to be reused in the generated code of a model reference hierarchy that includes multiple instances of a subsystem across referenced models. In this case, the subsystem must be in a library.

Command-Line Information

See “Block-Specific Parameters” (Simulink) for the command-line information.

Characteristics

Data Types	Double Single Boolean Base Integer Fixed-Point Enumerated Bus
------------	---

Multidimensional Signals	Yes
Variable-Size Signals	Yes
HDL Code Generation	Yes

Extended Capabilities

C/C++ Code Generation

Generate C and C++ code using Simulink® Coder™.

Actual code generation support depends on block implementation.

HDL Code Generation

Generate Verilog and VHDL code for FPGA and ASIC designs using HDL Coder™.

HDL Coder provides additional configuration options that affect HDL implementation and synthesized logic.

HDL Architecture

Architecture	Description
Module (default)	Generate code for the subsystem and the blocks within the subsystem.
BlackBox	Generate a black box interface. The generated HDL code includes only the input/output port definitions for the subsystem. Therefore, you can use a subsystem in your model to generate an interface to existing, manually written HDL code. The black-box interface generation for subsystems is similar to the Model block interface generation without the clock signals.
No HDL	Remove the subsystem from the generated code. You can use the subsystem in simulation, however, treat it as a “no-op” in the HDL code.

Black Box Interface Customization

For the BlackBox architecture, you can customize port names and set attributes of the external component interface. See “Customize Black Box or HDL Cosimulation Interface”.

HDL Block Properties

General	
AdaptivePipelining	Automatic pipeline insertion based on the synthesis tool, target frequency, and multiplier word-lengths. The default is <code>inherit</code> . See also “AdaptivePipelining”.
BalanceDelays	Detects introduction of new delays along one path and inserts matching delays on the other paths. The default is <code>inherit</code> . See also “BalanceDelays”.
ClockRatePipelining	Insert pipeline registers at a faster clock rate instead of the slower data rate. The default is <code>inherit</code> . See also “ClockRatePipelining”.

General	
ConstrainedOutputPipeline	Number of registers to place at the outputs by moving existing delays within your design. Distributed pipelining does not redistribute these registers. The default is 0. For more details, see “ConstrainedOutputPipeline”.
DistributedPipelining	Pipeline register distribution, or register retiming. The default is off. See also “DistributedPipelining”.
DSPStyle	Synthesis attributes for multiplier mapping. The default is none. See also “DSPStyle”.
FlattenHierarchy	Remove subsystem hierarchy from generated HDL code. The default is inherit. See also “FlattenHierarchy”.
InputPipeline	Number of input pipeline stages to insert in the generated code. Distributed pipelining and constrained output pipelining can move these registers. The default is 0. For more details, see “InputPipeline”.
OutputPipeline	Number of output pipeline stages to insert in the generated code. Distributed pipelining and constrained output pipelining can move these registers. The default is 0. For more details, see “OutputPipeline”.
SharingFactor	Number of functionally equivalent resources to map to a single shared resource. The default is 0. See also “Resource Sharing”.
StreamingFactor	Number of parallel data paths, or vectors, that are time multiplexed to transform into serial, scalar data paths. The default is 0, which implements fully parallel data paths. See also “Streaming”.

If this block is not the DUT, the block property settings in the **Target Specification** tab are ignored. In the HDL Workflow Advisor, if you use the **IP Core Generation** workflow, these target specification block property values are saved with the model. If you specify these target specification block property values using `hdlset_param`, when you open HDL Workflow Advisor, the fields are populated with the corresponding values.

Target Specification	
AdditionalTargetInterfaces	<p>Additional target interfaces, specified as a character vector.</p> <p>To save this block property on the model, in the Set Target Interface task of the IP Core Generation workflow, corresponding to the DUT ports that you want to add more interfaces, select Add more... You can then add more interfaces in the Add New Target Interfaces dialog box. Specify the type of interface, number of additional interfaces, and a unique name for each additional interface.</p> <p>Values: '' (default) cell array of character vectors</p> <p>Example: '{{'AXI4-Stream', 'InterfaceID', 'AXI4-Stream1'}}'</p>

Target Specification	
ProcessorFPGASynchronization	<p>Processor/FPGA synchronization mode, specified as a character vector.</p> <p>To save this block property on the model, specify the Processor/FPGA Synchronization in the Set Target Interface task of the IP Core Generation workflow.</p> <p>Values: Free running (default) Coprocessing - blocking</p> <p>Example: 'Free running'</p>
TestPointMapping	<p>To save this block property on the model, specify the mapping of test point ports to target platform interfaces in the Set Target Interface task of the IP Core Generation workflow.</p> <p>Values: '' (default) cell array of character vectors</p> <p>Example: '{'TestPoint', 'AXI4-Lite', 'x"108"'}'</p>
TunableParameterMapping	<p>To save this block property on the model, specify the mapping of tunable parameter ports to target platform interfaces in the Set Target Interface task of the IP Core Generation workflow.</p> <p>Values: '' (default) cell array of character vectors</p> <p>Example: '{'myParam', 'AXI4-Lite', 'x"108"'}'</p>
AXI4RegisterReadback	<p>To save this block property on the model, specify whether you want to enable readback on AXI4 slave write registers in the Generate RTL Code and IP Core task of the IP Core Generation workflow. To learn more, see "Model Design for AXI4 Slave Interface Generation".</p> <p>Values: 'off' (default) 'on'</p>
AXI4SlaveIDWidth	<p>To save this block property on the model, specify the number of AXI Master interfaces that you want to connect the DUT IP core to by using the AXI4 Slave ID Width setting in the Generate RTL Code and IP Core task of the IP Core Generation workflow. To learn more, see "Define Multiple AXI Master Interfaces in Reference Designs to access DUT AXI4 Slave Interface".</p> <p>Values: 'off' (default) 'on'</p>
AXI4SlavePortToPipelineRegisterRatio	<p>To save this block property on the model, specify the number of AXI4 slave ports for which you want a pipeline register to be inserted by using the AXI4 Slave port to pipeline register ratio setting in the Generate RTL Code and IP Core task of the IP Core Generation workflow. To learn more, see "Model Design for AXI4 Slave Interface Generation".</p> <p>Values: 'off' (default) 'on'</p>
GenerateDefaultAXI4Slave	<p>To save this block property on the model, specify whether you want to disable generation of default AXI4 slave interfaces in the Generate RTL Code and IP Core task of the IP Core Generation workflow.</p> <p>Values: 'on' (default) 'off'</p>

Target Specification	
IPCoreAdditionalFiles	<p>Verilog or VHDL files for black boxes in your design. Specify the full path to each file, and separate file names with a semicolon (;).</p> <p>You can set this property in the HDL Workflow Advisor, in the Additional source files field.</p> <p>Values: ' ' (default) character vector</p> <p>Example: 'C:\myprojfiles \led_blinking_file1.vhd;C:\myprojfiles \led_blinking_file2.vhd;'</p>
IPCoreName	<p>IP core name, specified as a character vector.</p> <p>You can set this property in the HDL Workflow Advisor, in the IP core name field. If this property is set to the default value, the HDL Workflow Advisor constructs the IP core name based on the name of the DUT.</p> <p>Values: ' ' (default) character vector</p> <p>Example: 'my_model_name'</p>
IPCoreVersion	<p>IP core version number, specified as a character vector.</p> <p>You can set this property in the HDL Workflow Advisor, in the IP core version field. If this property is set to the default value, the HDL Workflow Advisor sets the IP core version.</p> <p>Values: ' ' (default) character vector</p> <p>Example: '1.3'</p>
IPDataCaptureBuffer Size	<p>FPGA Data Capture buffer size, specified as a character vector. Use FPGA Data Capture to observe signals in a design when running on an FPGA.</p> <p>The buffer size uses values that are $128 \cdot 2^n$, where n is an integer. By default, the buffer size is 128 ($n=0$). The maximum value of n is 13, which means that the maximum value for buffer size is 1048576 ($=128 \cdot 2^{13}$).</p> <p>Values: ' ' (default) character vector</p> <p>Example: '1.3'</p>

Restrictions

- Your DUT cannot be an Enabled Synchronous Subsystem.
- You cannot have a Delay block with an external reset port inside the subsystem.
- You cannot generate HDL for the LTE Turbo Decoder block inside an Enabled Synchronous Subsystem.

See Also

Enable | Resettable Synchronous Subsystem | State Control | Synchronous Subsystem

Topics

“Resettable Subsystem Support in HDL Coder™”

“Using the State Control block to generate more efficient code with HDL Coder™”

“Synchronous Subsystem Behavior with the State Control Block”

Introduced in R2016a

Float Typecast

Typecast a floating-point type to an unsigned integer or vice versa

Library: HDL Coder / HDL Floating Point Operations

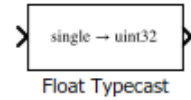

Description

The block casts the underlying bits of the input to the corresponding fixed-point or floating point representation. The input and output of the block contain the same number of bits.

Input Data Type	Output Data Type
single	uint32
double	ufix64
uint32	single
ufix64	double

This figure shows how the block mask, behavior, and output data type changes dynamically depending on the input data type that you specify.

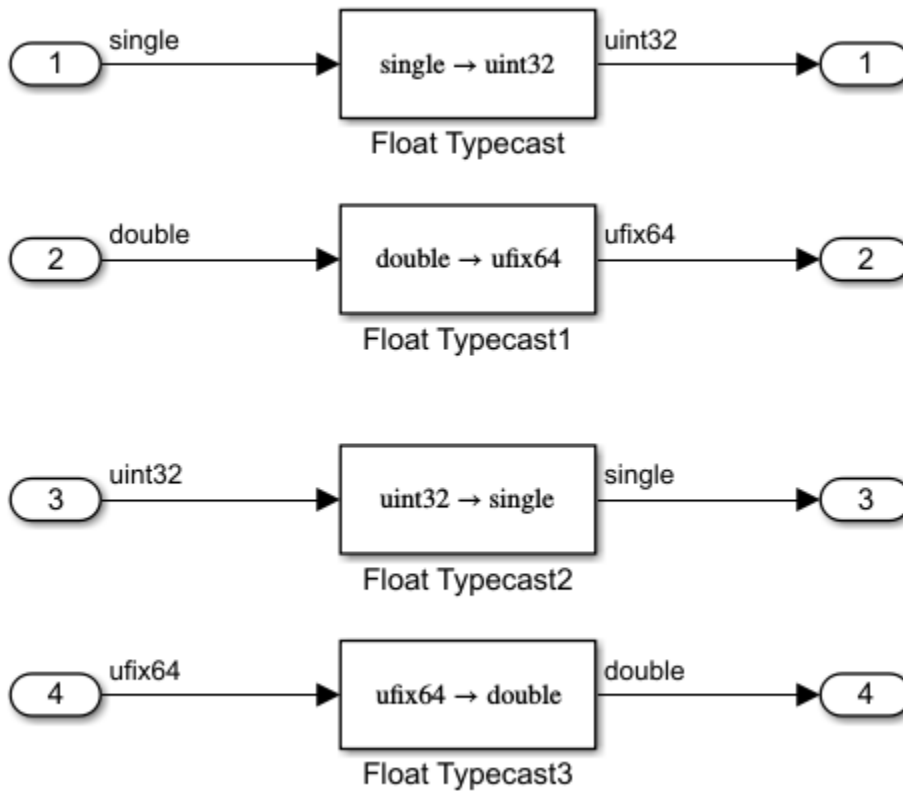

Ports

Input

Port_1(u) – Input signal

scalar | vector

Port to provide input to the block.

Data Types: single | double | uint32 | fixed point

Output

Port_1(y) – Output signal

scalar | vector

Port to obtain calculated output from the block.

Data Types: single | double | uint32 | fixed point

Extended Capabilities

HDL Code Generation

Generate Verilog and VHDL code for FPGA and ASIC designs using HDL Coder™.

The block supports HDL code generation in the **Native Floating Point** mode. To use this mode, specify `single` or `uint32` data types as input to the block. With the HDL Code Advisor, you can replace Data Type Conversion blocks that use the **Stored Integer (SI)** mode and convert between floating-point and fixed-point data types.

The block supports code generation for complex signals.

See Also

Functions

`typecast`

Topics

“Getting Started with HDL Coder Native Floating-Point Support”

Introduced in R2017b

HDL Counter

Free-running or count-limited hardware counter

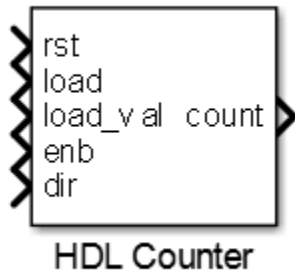

Library

HDL Coder / Sources

Description

The HDL Counter block models a free-running or count-limited hardware counter that supports signed and unsigned integer and fixed-point data types.

The counter emits its value for the current sample time.

This block does not report wrap on overflow warnings during simulation. To report these warnings, see the `Simulink.restoreDiagnostic` reference page. The block does report errors due to wrap on overflow.

Control Ports

By default, the counter does not have input ports. Optionally, you can add control ports that enable, disable, load, reset or set the direction of the counter.

The table shows the priority of the control signals and how the counter value is updated in relation to the control signals.

Local reset, rst	Load trigger, load	Count enable, enb	Count direction, dir	Next Counter Value
1	–	–	–	initial value
0	1	–	–	load_val value
0	0	0	–	current value
0	0	1	1	current value + step value
0	0	1	0	current value - step value

Count direction

The **Step value** parameter and optional count direction port, `dir`, interact to determine the actual count direction.

dir Signal Value	Step Value Sign	Actual Count Direction
1	+ (positive)	Up
1	- (negative)	Down
0	+ (positive)	Down
0	- (negative)	Up

Parameters

Counter type

Counter behavior.

- **Free running** (default): The counter continues to increment or decrement by the **Step value** until reset.
- **Count limited**: The counter increments or decrements by the **Step value** until it is exactly equal to the **Count to value**.

Initial value

Counter value after reset. The default is 0.

Step value

Value added to counter at each sample time. The default is 1.

Count to value

When the count is exactly equal to **Count to value**, the count restarts at the **Initial value**. This option is available when **Counter type** is set to **Count limited**. The default is 100.

Count from

Specifies the parameter that sets the start value after rollover. When set to **Specify**, the **Count from value** parameter is the start value after rollover. The default is **Initial value**.

Count from value

Counter value after rollover when **Count from** is set to **Specify**. The default is 0.

Local reset port

When selected, creates a local reset port, `rst`.

Load ports

When selected, creates a load data port, `load_val`, and load trigger port, `load`.

Count enable port

When selected, creates a count enable port, `enb`.

Count direction port

When selected, creates a count direction port, `dir`.

Counter output data is

Output data type signedness. The default is **Unsigned**.

Word length

Bit width, including sign bit, for an integer counter; word length for a fixed-point data type counter. The minimum value if Output data type is Unsigned is 1, 2 if Signed. The maximum value is 125. The default is 8.

Fraction length

Fixed-point data type fraction length. The default is 0.

Sample time

Sample time. The default is 1.

This parameter is not available, and the block inherits its sample time from the input ports when any of these parameters is selected:

- **Local reset port**
- **Load ports**
- **Count enable port**
- **Count direction port**

Ports

The block has the following ports:

`rst`

Resets the counter value. Active-high.

This port is available when you select **Local reset port**.

Data type: Boolean

`load`

Sets the counter to the load value, `load_val`. Active-high.

This port is available when you select **Load ports**.

Data type: Boolean

`load_val`

Data value to load.

This port is available when you select **Load ports**.

Data type: Same as `count`.

`enb`

Enables counter operation. Active-high.

This port is available when you select **Count enable port**.

Data type: Boolean

`dir`

Count direction. This port interacts with **Step value** to determine count direction.

- **1: Step value** is added to the current counter value to compute the next value.
- **0: Step value** is subtracted from the current counter value to compute the next value.

This port is available when you select **Count direction port**.

Data type: Boolean

count

Counter value.

Data type: Determined automatically based on **Counter output data is**, **Word length**, and **Fraction length**.

Extended Capabilities

HDL Code Generation

Generate Verilog and VHDL code for FPGA and ASIC designs using HDL Coder™.

HDL Coder provides additional configuration options that affect HDL implementation and synthesized logic.

HDL Architecture

This block has a single, default HDL architecture.

HDL Block Properties

General	
ConstrainedOutputPipeline	Number of registers to place at the outputs by moving existing delays within your design. Distributed pipelining does not redistribute these registers. The default is 0. For more details, see "ConstrainedOutputPipeline".
InputPipeline	Number of input pipeline stages to insert in the generated code. Distributed pipelining and constrained output pipelining can move these registers. The default is 0. For more details, see "InputPipeline".
OutputPipeline	Number of output pipeline stages to insert in the generated code. Distributed pipelining and constrained output pipelining can move these registers. The default is 0. For more details, see "OutputPipeline".

Restrictions

If the bitwidth of the input signal to a HDL Counter exceeds the data type limit, the generated HDL code can produce incorrect simulation results. To accommodate the larger bit width, use a larger data type.

Introduced in R2014a

HDL FIFO

Stores sequence of input samples in first in, first out (FIFO) register

Library: HDL Coder / HDL RAMs

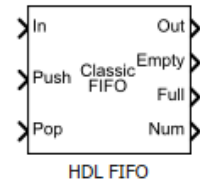

Description

The HDL FIFO block stores a sequence of input samples in a first in, first out (FIFO) register. The data written first into the FIFO register comes out first. The block implementation resembles the FIFO unit in hardware platforms in terms of functionality and behavior.

Ports

Input

In — Data input signal

scalar

Data input signal to the FIFO block. When you write data into the FIFO, the newest data is pushed to the end of the FIFO register. The block pushes subsequent data entries below this entry.

Data Types: `single` | `double` | `int8` | `int16` | `int32` | `int64` | `uint8` | `uint16` | `uint32` | `uint64` | `Boolean` | `fixed point`

Push — Write control signal

scalar

When this port receives a value of 1, the block pushes the input at the In port onto the end of the FIFO register.

Data Types: `Boolean`

Pop — Read control signal

scalar

When this port receives a value of 1, the block pops the first element off the FIFO register and holds the Out port at that value.

Data Types: `Boolean`

Note If two or more of the control input ports are triggered in the same time step, the pop operation executes first, followed by the push operation.

Output

Out — Data output signal

scalar

Data output signal from the FIFO block. When you read data from the FIFO, the data that you wrote first into the FIFO register comes off the FIFO and is held at the output.

Data Types: `single` | `double` | `int8` | `int16` | `int32` | `int64` | `uint8` | `uint16` | `uint32` | `uint64` | `Boolean` | `fixed point`

Empty — Data output signal

scalar

Control signal output from the FIFO that becomes 1 when the FIFO register is empty and does not contain data entries.

Dependencies

To enable this port, **Show empty register indicator port (Empty)** must be selected.

Data Types: `Boolean`

Full — Data output signal

scalar

Control signal output from the FIFO that becomes 1 when the FIFO register is full and cannot take more data entries.

Dependencies

To enable this port, **Show full register indicator port (Full)** must be selected.

Data Types: `single` | `double` | `int8` | `int16` | `int32` | `int64` | `uint8` | `uint16` | `uint32` | `uint64` | `Boolean` | `fixed point`

Num — Number of entries

scalar

Number of data entries that are currently inside the FIFO register. **Num** increments by 1 for every data that you write into the FIFO. **Num** decrements by 1 for every data that you read from the FIFO.

Dependencies

To enable this port, **Show number of entries register port (Num)** must be selected.

Data Types: `single` | `double` | `int8` | `int16` | `int32` | `int64` | `uint8` | `uint16` | `uint32` | `uint64` | `Boolean` | `fixed point`

Parameters

Register size — Number of entries

10 (default)

Specify the number of entries that the FIFO register can hold. The default value for **Register size** is 10. The minimum value for **Register size** is 4.

Programmatic Use**Block parameter:** `fifo_size`**Type:** character vector**Value:** An integer greater than or equal to four**Default:** `'10'`**Mode — Operation mode**`'Classic'` (default) | `'FWFT'`

Specify the operation mode of the FIFO. By default, the **Mode** is set to `Classic`. You see that the block icon displays `Classic FIFO`. You can change the **Mode** to `FWFT`. When you change the **Mode**, the block icon displays `FWFT FIFO`. By using the `FWFT` mode, you can lookahead and see the first word written to the FIFO register without placing a read request. The `FWFT` mode is especially useful when you apply the back-pressure with AXI4-Stream interfaces.

Programmatic Use**Block parameter:** `mode`**Type:** character vector**Value:** `'Classic'` | `'FWFT'` |**Default:** `'Classic'`**The ratio of output sample time to input sample time — Sample rate ratio**`1` (default)

Specify the ratio of output sample time to input sample time. The default ratio is `1`, which means that the inputs `In` and `Push`, and outputs `Out` and `Pop`, run at the same sample rate. The inputs and outputs can run at different sample times. Use a positive integer or $1/N$, where N is a positive integer. For example, if you enter $1/2$, the output sample time is half the input sample time, or the outputs run faster. The `Full`, `Empty`, and `Num` signals run at the faster rate.

Programmatic Use**Block parameter:** `ratio`**Type:** character vector**Value:** An integer greater than or equal to one**Default:** `'1'`**Push onto full register — Overflow condition**`'Warning'` (default) | `'Ignore'` | `'Error'`

Specify how you want the block to respond when you write to a FIFO that is full. The default is `Warning`.

Programmatic Use**Block parameter:** `push_msg`**Type:** character vector**Value:** `'Warning'` | `'Ignore'` | `'Error'`**Default:** `'Warning'`**Pop onto empty register — Underflow condition**`'Warning'` (default) | `'Ignore'` | `'Error'`

Specify how you want the block to respond when you read from a FIFO that is empty. The default is `Warning`.

Programmatic Use**Block parameter:** pop_msg**Type:** character vector**Value:** 'Warning' | 'Ignore' | 'Error'**Default:** 'Warning'**Show empty register indicator port (Empty) — Optional empty port**

on (default) | off

Specify whether to enable the Empty output port. This port outputs a 1 when the FIFO register is empty and 0 when the FIFO contains one or more data entries.

Programmatic Use**Block parameter:** show_empty**Type:** character vector**Value:** 'on' | 'off'**Default:** 'on'**Show full register indicator port (Full) — Optional full port**

on (default) | off

Specify whether to enable the Full output port. This port outputs a 1 when the FIFO register is full.

Programmatic Use**Block parameter:** show_full**Type:** character vector**Value:** 'on' | 'off'**Default:** 'on'**Show num register indicator port (Num) — Optional num port**

on (default) | off

Specify whether to enable the Num output port. This port outputs the number of data entries that are currently available in the FIFO queue.

Programmatic Use**Block parameter:** show_num**Type:** character vector**Value:** 'on' | 'off'**Default:** 'on'

Algorithms

FIFO Write Operation

This figure displays the FIFO write operation. The **Push** input port acts as the enable signal for the write operation. This signal is denoted by the **write_en** signal in the figure.

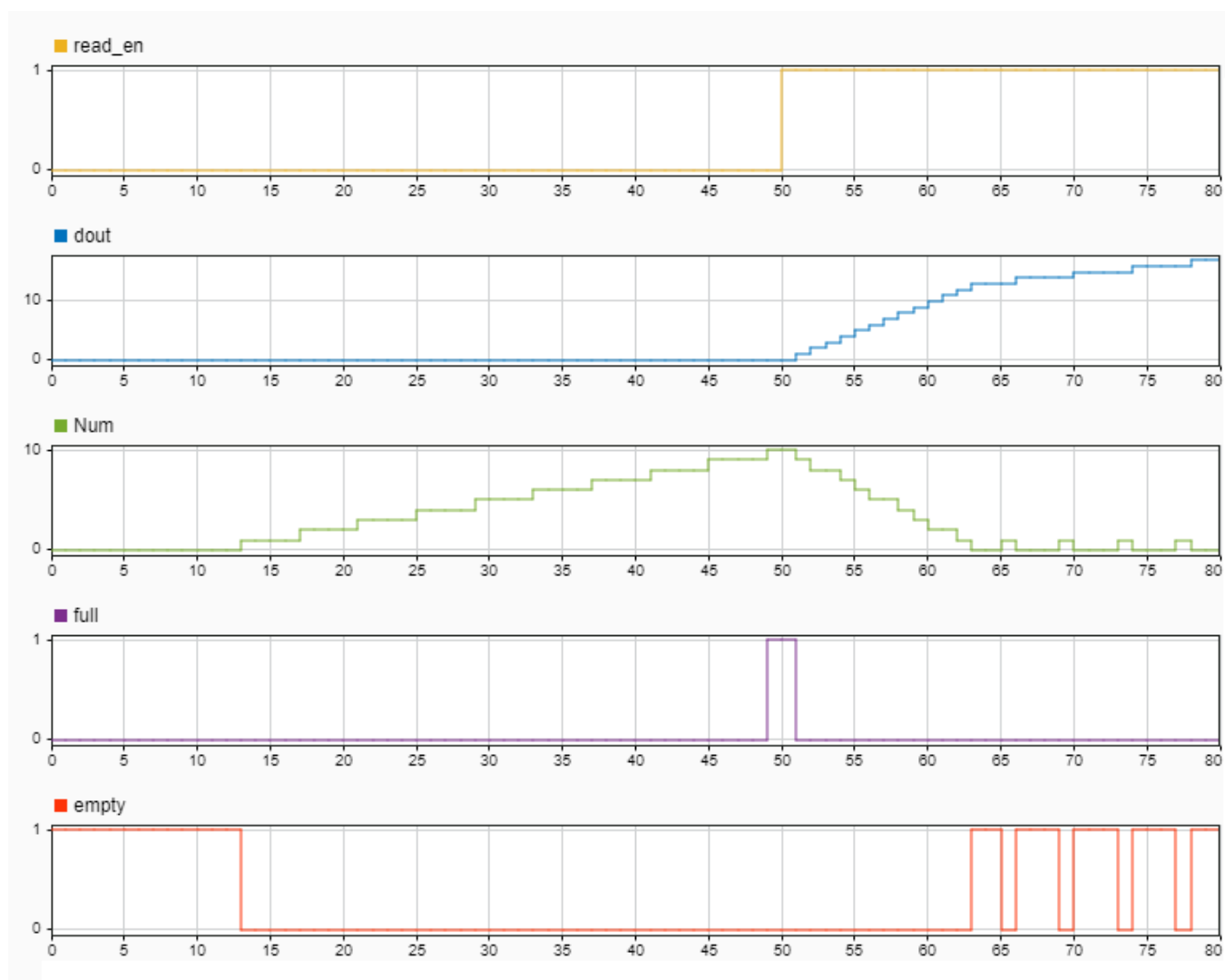

When the **read_en** signal is 0, the block output **dout** is 0. When the **read_en** signal becomes 1 at time step 50, the **dout** signal outputs the oldest entry in the FIFO in the next time step 51. The **Full** flag is de-asserted and the **Num** signal decrements by 1 starting from time step 51 as you read data from the FIFO.

When the **Num** signal becomes equal to 0, the **Empty** signal is asserted. After the **Empty** signal becomes 0, if you try to read more entries from the FIFO, the block generates a warning.

FWFT FIFO Read Operation

This figure displays the FIFO read operation. The **Pop** input port acts as the enable signal for the read operation. This signal is denoted by the **read_en** signal in the figure.

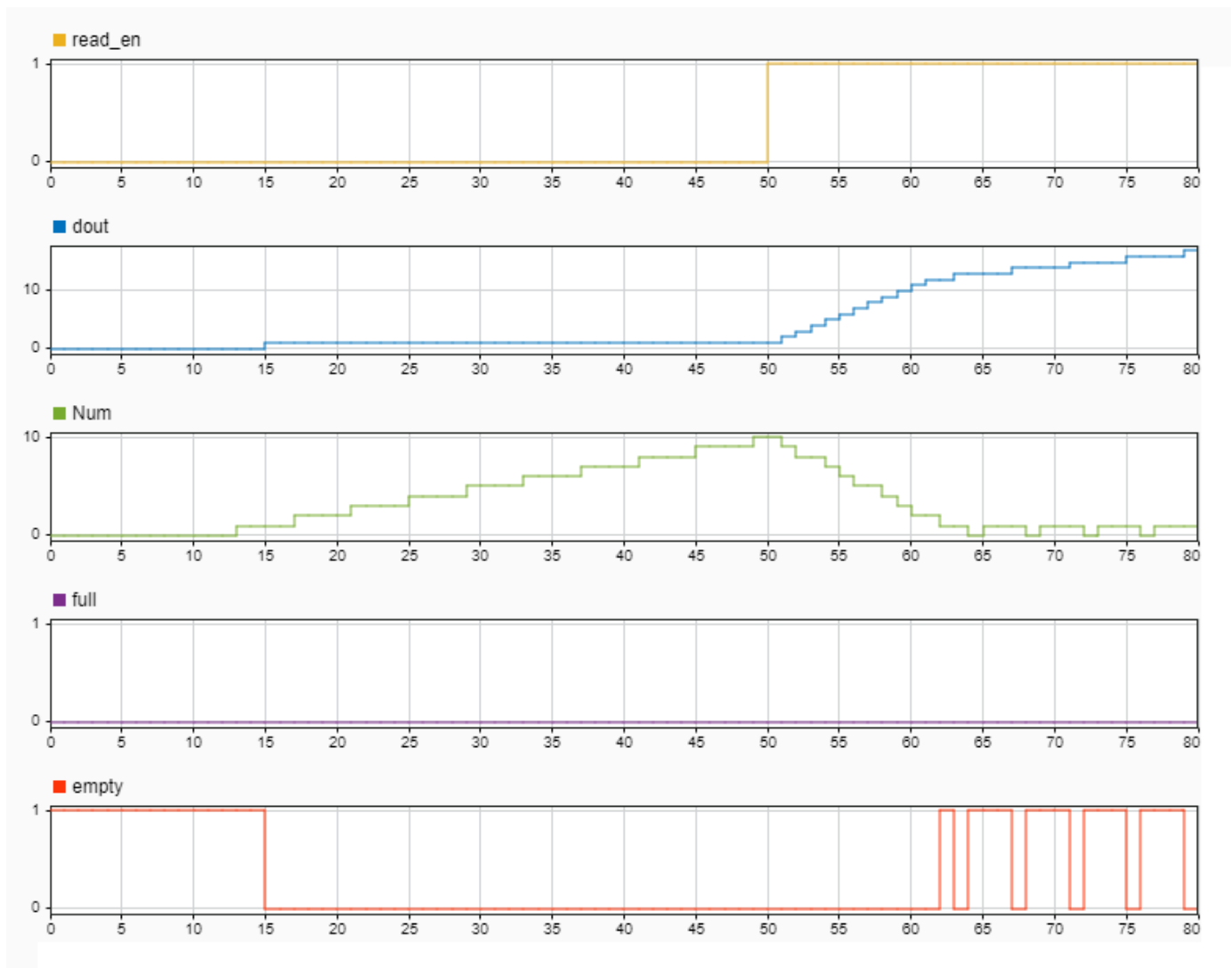

By default, the HDL FIFO works in the **Classic** mode. You can also use a first-word-fall-through (FWFT) mode for the FIFO. In the Block Parameters dialog box, specify the **Mode** as FWFT.

In the FWFT mode, the write operation works in the same way as the **Classic** mode. The FWFT mode differs from the **Classic** mode when you perform a read operation. In the **Classic** mode, after you place a read request or input a 1 to the **Pop** port, the data becomes available at the FIFO output in the next clock cycle. In the FWFT mode, the first word you write to the FIFO falls through to the output and is available at the output signal **Out**.

In the figure, though **read-en** becomes 1 at time step 50, the FIFO read the first word **dout** at time step 15. You can use this capability to look ahead and see the first word that has been written to the FIFO.

Extended Capabilities

HDL Code Generation

Generate Verilog and VHDL code for FPGA and ASIC designs using HDL Coder™.

HDL Coder provides additional configuration options that affect HDL implementation and synthesized logic.

HDL Architecture

This block has a single, default HDL architecture.

HDL Block Properties

General	
ConstrainedOutputPipeline	Number of registers to place at the outputs by moving existing delays within your design. Distributed pipelining does not redistribute these registers. The default is 0. For more details, see "ConstrainedOutputPipeline".
InputPipeline	Number of input pipeline stages to insert in the generated code. Distributed pipelining and constrained output pipelining can move these registers. The default is 0. For more details, see "InputPipeline".
OutputPipeline	Number of output pipeline stages to insert in the generated code. Distributed pipelining and constrained output pipelining can move these registers. The default is 0. For more details, see "OutputPipeline".

See Also

Simple Dual Port RAM | Dual Rate Dual Port RAM

Topics

"Design Considerations for RAM Blocks and Blocks in HDL Operations Library"

Introduced in R2014a

HDL Reciprocal

Calculate reciprocal with Newton-Raphson approximation method

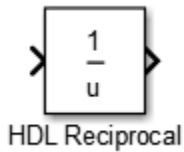

Library

HDL Coder / Math Operations

Description

The HDL Reciprocal block uses the Newton-Raphson iterative method to compute the reciprocal of the block input. The Newton-Raphson method uses linear approximation to successively find better approximations to the roots of a real-valued function.

The reciprocal of a real number a is defined as a zero of the function:

$$f(x) = \frac{1}{x} - a$$

HDL Coder chooses an initial estimate in the range $0 < x_0 < \frac{2}{a}$ as this is the domain of convergence for the function.

To successively compute the roots of the function, specify the **Number of iterations** parameter in the Block Parameters dialog box. The process is repeated as:

$$x_{i+1} = x_i - \frac{f(x_i)}{f'(x_i)} = x_i + (x_i - ax_i^2) = x_i \cdot (2 - ax_i)$$

$f'(x)$ is the derivative of the function $f(x)$.

Following table shows comparison of simulation behavior of HDL Reciprocal with Math Reciprocal block:

Math Reciprocal	HDL Reciprocal
Computes the reciprocal as $1/N$ by using the HDL divide operator (/) to implement the division.	Uses the Newton-Raphson iterative method. The block computes an approximate value of reciprocal of the block input and can yield different simulation results compared to the Math Reciprocal block.
	To match the simulation results with the Math Reciprocal block, increase the number of iterations for the HDL Reciprocal block.

Parameters

Number of iterations

Number of Newton-Raphson iterations. The default is 3.

Ports

The block has the following ports:

Input

- Supported data types: Fixed-point, integer (signed or unsigned), double, single
- Minimum bit width: 2
- Maximum bit width: 128

Output

Input data type	Output data type
double	double
single	single
built-in integer	built-in integer
built-in fixed-point	built-in fixed-point
<i>fi (value, 0, word_length, fraction_length)</i>	<i>fi (value, 0, word_length, word_length-fraction_length-1)</i>
<i>fi (value, 1, word_length, fraction_length)</i>	<i>fi (value, 1, word_length, word_length-fraction_length-2)</i>

Extended Capabilities

C/C++ Code Generation

Generate C and C++ code using Simulink® Coder™.

HDL Code Generation

Generate Verilog and VHDL code for FPGA and ASIC designs using HDL Coder™.

HDL Coder provides additional configuration options that affect HDL implementation and synthesized logic.

HDL Architecture

This block has multi-cycle implementations that introduce additional latency in the generated code. To see the added latency, view the generated model or validation model. See “Generated Model and Validation Model”.

Architecture	Additional cycles of latency	Description
ReciprocalNewton (default)	Iterations + 1	<p>Use the multirate implementation of the iterative Newton method. Select this option to optimize area.</p> <p>The default value for <code>Iterations</code> is 3.</p> <p>The recommended value for <code>Iterations</code> is from 2 through 10. If <code>Iterations</code> is outside the recommended range, HDL Coder displays a message.</p>
ReciprocalNewtonSingleRate	(Iterations * 2) + 1	<p>Use the single rate pipelined Newton method. Select this option to optimize speed, or if you want a single rate implementation.</p> <p>The default value for <code>Iterations</code> is 3.</p> <p>The recommended value for <code>Iterations</code> is between 2 and 10. If <code>Iterations</code> is outside the recommended range, the coder displays a message.</p>

HDL Block Properties

General	
ConstrainedOutputPipeline	Number of registers to place at the outputs by moving existing delays within your design. Distributed pipelining does not redistribute these registers. The default is 0. For more details, see "ConstrainedOutputPipeline".
InputPipeline	Number of input pipeline stages to insert in the generated code. Distributed pipelining and constrained output pipelining can move these registers. The default is 0. For more details, see "InputPipeline".
OutputPipeline	Number of output pipeline stages to insert in the generated code. Distributed pipelining and constrained output pipelining can move these registers. The default is 0. For more details, see "OutputPipeline".

See Also

Divide | Math Function

Introduced in R2014b

Multiply-Accumulate

Perform a multiply-accumulate operation on the inputs

Library: HDL Coder / HDL Operations

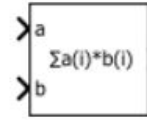

Multiply-Accumulate

Description

The Multiply-Accumulate block performs this operation on inputs **a** and **b**, and bias **c**, to compute result **dataOut**.

$$\text{dataOut} = \text{sum}(\mathbf{a}.*\mathbf{b}) + \mathbf{c}$$

By default, the block operates in the vector mode. The inputs **a** and **b** can be scalars, vectors, or 2-D matrices. By default, the bias value **c** is equal to zero, and the block computes the dot product of inputs **a** and **b**. You can specify a nonzero value for **c** by using **Dialog** or **Input port** as the **Source**. The block adds this bias to the dot product of **a** and **b**. The multiplication operation is full precision irrespective of the **Output data type** setting. The **Output data type** and **Integer rounding mode** settings apply to the addition operation.

By using the **Operation Mode** setting, you can specify streaming modes of operation for the Multiply-Accumulate block. For HDL code generation, when you use the streaming operation mode, input scalar values to the block. The block has two streaming modes: **Streaming - using Start and End ports** and **Streaming - using Number of Samples**. When you select these streaming modes, you can specify the control signals to use with the mode. The control signals specify when to start and end accumulation, and when the output is valid.

Limitations for HDL Code Generation

- Scalar inputs are not supported for HDL code generation. To generate code for the block, use vector inputs. With scalar inputs, use the Multiply-Add block.
- Matrix data types are not supported at the block port interfaces. If you have matrix type signals, use the Product block in matrix multiplication mode.
- Streaming modes of operation for the block are not supported inside a Resettable Subsystem block for HDL code generation.

Ports

Input

a – Input signal

vector | matrix | array | bus

Port to provide input to the block.

Data Types: single | double | int8 | int16 | int32 | uint8 | uint16 | uint32 | fixed point

b – Input signal

scalar | vector | matrix | array | bus

Port to provide input to the block.

Data Types: single | double | int8 | int16 | int32 | uint8 | uint16 | uint32 | Boolean | fixed point | enumerated | bus

c – Bias signal

scalar | vector | matrix | array | bus

Port to provide the bias signal to the block. The block adds this bias to the inputs. Make sure that the bias signal data type matches that of the dot product of the inputs.

DependenciesTo enable this port, set **Source** to Input port.

Data Types: single | double | int8 | int16 | int32 | uint8 | uint16 | uint32 | fixed point

startIn – Start of accumulation control signal

scalar | vector | matrix | array | bus

Port to provide the control signal to start accumulation. It is recommended that you use a boolean data type signal as input to the port. To start obtaining the accumulated output value from the **dataOut** signal, both **startIn** and **validIn** signals must be high. The **dataOut** signal produces the accumulated result from the next clock cycle.**Dependencies**To enable this port, set **Operation Mode** to Streaming - using Start and End Ports.

Data Types: single | double | int8 | int16 | int32 | uint8 | uint16 | uint32 | fixed point

validIn – Valid input control signal

scalar | vector | matrix | array | bus

Port to provide the control signal to indicate that the input signal is valid for accumulation. It is recommended that you use a boolean data type signal as input to the port. To start obtaining the accumulated output value from the **dataOut** signal, both **validIn** and **startIn** signals must be high. The **dataOut** signal produces the accumulated result from the next clock cycle. The **validIn** signal has higher priority than **startIn** and **endIn** signals.**Dependencies**To enable this port, set **Operation Mode** to Streaming - using Start and End Ports or Streaming - using Number of Samples.

Data Types: single | double | int8 | int16 | int32 | uint8 | uint16 | uint32 | fixed point

endIn – End of accumulation control signal

scalar | vector | matrix | array | bus

Port to provide the control signal to indicate end of accumulation. You can use the **startIn** and **endIn** signals with the **validIn** signal to indicate a frame that contains the accumulated output.

Dependencies

To enable this port, set **Operation Mode** to Streaming - using Start and End Ports and then select **End input and output ports**.

Data Types: single | double | int8 | int16 | int32 | uint8 | uint16 | uint32 | fixed point

Output**dataOut — Output signal**

scalar | vector | matrix | array | bus

Port that generates the output data from the multiply-accumulate operation. By default, the block uses the **Vector** mode of operation and computes the dot product of the input signals, and adds the bias to produce the result. If you specify a streaming mode of operation as **Operation Mode**, the value of the **dataOut** signal depends on the control signals that you provide. The data type of the output signal is same as that of the accumulator.

Data Types: single | double | int8 | int16 | int32 | uint8 | uint16 | uint32 | fixed point

startOut — Start of accumulation output control signal

scalar | vector | matrix | array | bus

Port that generates output control signal to indicate the start of accumulation. When both **validIn** and **startIn** are high, the **startOut** signal becomes high in the next clock cycle. The clock cycle at which **startOut** becomes high indicates the start of a frame and that the **dataOut** signal has started producing valid accumulated output.

Dependencies

To enable this port, set **Operation Mode** to Streaming - using Start and End Ports and then select **Start output port**.

Data Types: single | double | int8 | int16 | int32 | uint8 | uint16 | uint32 | fixed point

validOut — Valid output control signal

scalar | vector | matrix | array | bus

Port that generates the output control signal to indicate that the **dataOut** signal is valid. When the **validIn** signal becomes high, the **validOut** signal becomes high in the next clock cycle and indicates that the **dataOut** is valid.

Dependencies

To enable this port, set **Operation Mode** to Streaming - using Start and End Ports and then select **Valid output port**.

Data Types: single | double | int8 | int16 | int32 | uint8 | uint16 | uint32 | fixed point

endOut — End of accumulation output control signal

scalar | vector | matrix | array | bus

Port that generates the output control signal to indicate the end of accumulation. You can use the clock cycles between when the **startOut** signal becomes high and when the **endOut** signal becomes high to indicate a valid frame that contains the accumulated output.

Dependencies

To enable this port, set **Operation Mode** to Streaming - using Start and End Ports and then select **End input and output ports**.

Data Types: single | double | int8 | int16 | int32 | uint8 | uint16 | uint32 | fixed point

countOut — Count output control signal

scalar | vector | matrix | array | bus

Port that generates the output control signal to indicate number of samples to accumulate. The value of this signal increases from 1 to the value that you specify for **Number of Samples**. As long as the **validIn** signal is high, the **countOut** increments by 1 every clock cycle.

Dependencies

To enable this port, set **Operation Mode** to Streaming - using Number of Samples and then select **Count output port**.

Data Types: single | double | int8 | int16 | int32 | uint8 | uint16 | uint32 | fixed point

Parameters**Operation Mode — Mode of accumulation of inputs**

'Vector' (default) | 'Streaming - using Start and End Ports' | 'Streaming - using Number of Samples'

You can specify the **Operation Mode** as:

- **Vector**: You can use scalars or vectors as inputs. The block performs the dot product of the inputs **u1** and **u2** and adds bias **k** to produce the result.
- **Streaming - using Start and End Ports**: Use scalar inputs for HDL code generation. In this mode, you can use the **startIn** and **endIn** control signals to determine when to start and stop accumulation. The output data is valid when **validIn** is high.
- **Streaming - using Number of Samples**: Use scalar inputs for HDL code generation. In this mode, you can specify the **Number of Samples** and use the **countIn** control signal to determine when to start and stop accumulation. The output data is valid when **validIn** is high.

Programmatic Use

Block parameter: opMode

Type: character vector

Value: 'Vector' | 'Streaming - using Start and End Ports' | 'Streaming - using Number of Samples'

Default: 'Vector'

Bias — Offset to add to the input dot product

{'0.0'} (default)

You can specify the bias with:

- **Source** as Dialog. Then, specify the **Value**.
- **Source** as Input port. This setting creates an external input port **c** to input the bias signal to the block.

Programmatic Use**Block parameter:** `initValueSetting`**Type:** character vector**Value:** 'Dialog' | 'Input port'**Default:** 'Dialog'

If you set **Source** as Dialog, you can specify the initial value by using the `initValue2` setting.

Block parameter: `initValue2`**Type:** character vector**Value:** An integer greater than or equal to zero**Default:** '0.0'**Number of Samples — Number of samples of valid accumulated output signal**`{'2'}` (default)

You can specify the **Number of Samples** to specify a frame containing the number of samples of valid accumulated output `dataOut`.

Dependencies

To enable this port, set **Operation Mode** to Streaming - using Number of Samples.

Programmatic Use**Block parameter:** `num_samples`**Type:** character vector**Value:** An integer greater than or equal to zero**Default:** '2'**Output data type — Data type of the block output**`Inherit: Inherit via back propagation` (default)

Set the output data type to:

- A rule that inherits a data type, such as `Inherit: Same as first input`.
- A built-in data type, such as `single` or `int16`.
- The name of a data type object. for instance, a `Simulink.NumericType` object.
- An expression that evaluates to a valid data type, for example, `fixdt(1,16,0)`

The streaming modes do not support `Inherit: Inherit via internal rule`. When you set the **Output data type**, you can use the **Data Type Assistant**. To display the assistant, click the **Show**

data type assistant  .

Programmatic Use**Block parameter:** `OutDataTypeStr`**Type:** character vector**Default:** {'Inherit: Inherit via internal rule'}

To see possible values that you can specify for this parameter, see “Block-Specific Parameters” (Simulink).

Integer rounding mode — Rounding mode for fixed-point operations`Floor` (default) | `Ceiling` | `Convergent` | `Nearest` | `Round` | `Simplest` | `Zero`

Specify the rounding action as:

Ceiling

Rounds positive and negative numbers toward positive infinity. Equivalent to the MATLAB `ceil` function.

Convergent

Rounds number to the nearest representable value. If a tie occurs, rounds to the nearest even integer. Equivalent to the Fixed-Point Designer™ `convergent` function.

Floor

Rounds positive and negative numbers toward negative infinity. Equivalent to the MATLAB `floor` function.

Nearest

Rounds the number to the nearest representable value. If a tie occurs, rounds toward positive infinity. Equivalent to the Fixed-Point Designer `nearest` function.

Round

Rounds number to the nearest representable value. If a tie occurs, rounds positive numbers toward positive infinity and rounds negative numbers toward negative infinity. Equivalent to the Fixed-Point Designer `round` function.

Simplest

Chooses between rounding toward floor and rounding toward zero to generate rounding code that is as efficient as possible.

Zero

Rounds number toward zero. Equivalent to the MATLAB `fix` function.

Programmatic Use

Block parameter: `RndMeth`

Type: character vector

Default: {'Floor'}

To see possible values that you can specify for this parameter, see “Block-Specific Parameters” (Simulink).

Valid output port — Control generation of `validOut` output port

`off` (default) | `on`

Control generation of the **`validOut`** output port. This port indicates whether **`dataOut`** is valid.

`off`

Does not display the **`validOut`** output port.

`on`

Display the **`validOut`** output port.

Dependencies

To enable this port, set **Operation Mode** to `Streaming - using Number of Samples` or `Streaming - using Start and End Ports`.

Programmatic Use

Block parameter: `validOut`

Type: character vector

Values: 'off' | 'on'

Default: 'off'

End input and output ports — Control generation of endIn input port and endOut output port

off (default) | on

Control generation of the **endIn** input port and the **endOut** output port. The ports indicate the end of a frame containing valid accumulation output.

off

Does not display the **endIn** input port and the **endOut** output port.

on

Display the **endIn** input port and the **endOut** output port.

Dependencies

To enable this port, set **Operation Mode** to Streaming - using Start and End Ports.

Programmatic Use

Block parameter: endInandOut

Type: character vector

Values: 'off' | 'on'

Default: 'off'

Start output port — Control generation of startOut output port

off (default) | on

Control generation of the **startOut** output port. This port generates the **startOut** signal that indicates the start of a frame containing valid accumulated output.

off

Does not display the **startOut** output port.

on

Display the **startOut** output port.

Dependencies

To enable this port, set **Operation Mode** to Streaming - using Start and End Ports.

Programmatic Use

Block parameter: startOut

Type: character vector

Values: 'off' | 'on'

Default: 'off'

Count output port — Control generation of countOut output port

off (default) | on

Control generation of the **countOut** output port. This port generates the counter that indicates a frame containing valid samples.

off

Does not display the **countOut** output port.

on

Display the **countOut** output port.

Dependencies

To enable this port, set **Operation Mode** to Streaming - using Number of Samples.

Programmatic Use

Block parameter: countOut

Type: character vector

Values: 'off' | 'on'

Default: 'off'

Benefits

With the Multiply-Accumulate block, you can:

- Perform matrix multiplication operations. For example, if you have two matrix inputs with dimensions N-by-M and M-by-P, you can compute the result by using N-by-P multiply-accumulate operations in parallel.
- Replace a sequence of multiplication and addition operations, such as in filter blocks, and improve the performance on hardware by mapping to DSP slices on the FPGA. This figure shows how you can use the Multiply-Accumulate block with the `sfir_fixed` model.

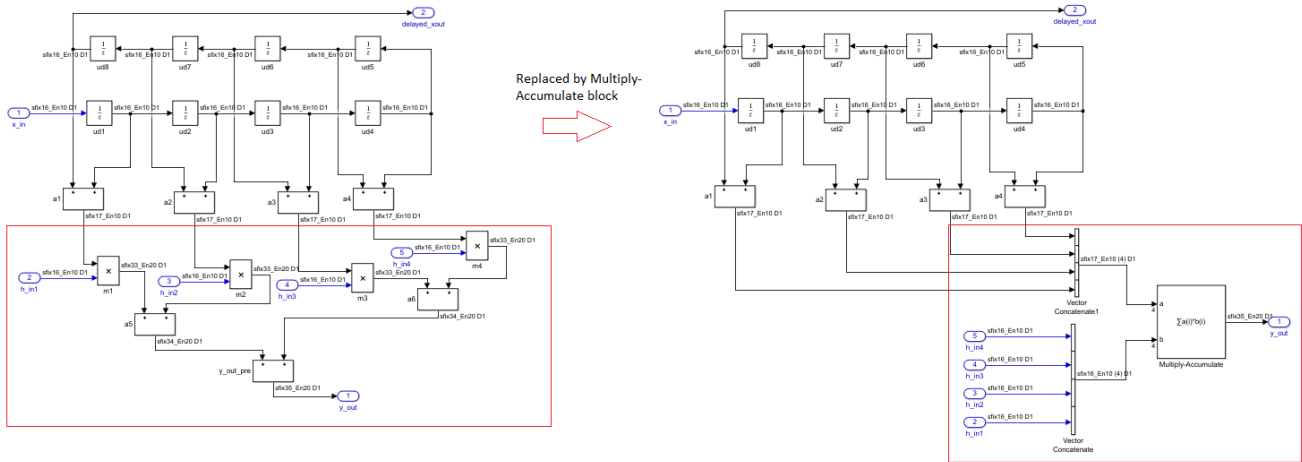

Algorithms

Streaming Mode Using Start and End Ports

You can use the **Operation Mode** setting for the block to specify a streaming mode of operation. When you select Streaming - using Start and End Ports, you see three additional settings enabled by default. The settings include:

- **Valid output port**
- **End input and output ports**
- **Start output port**

It is recommended that you leave these settings enabled. When you apply the settings, three additional input ports and three additional output ports appear:

Input Ports	Output Ports
startIn	startOut
validIn	validOut
endIn	endOut

This figure illustrates the streaming mode of operation using the start and end ports. In this example, the bias value is 8.

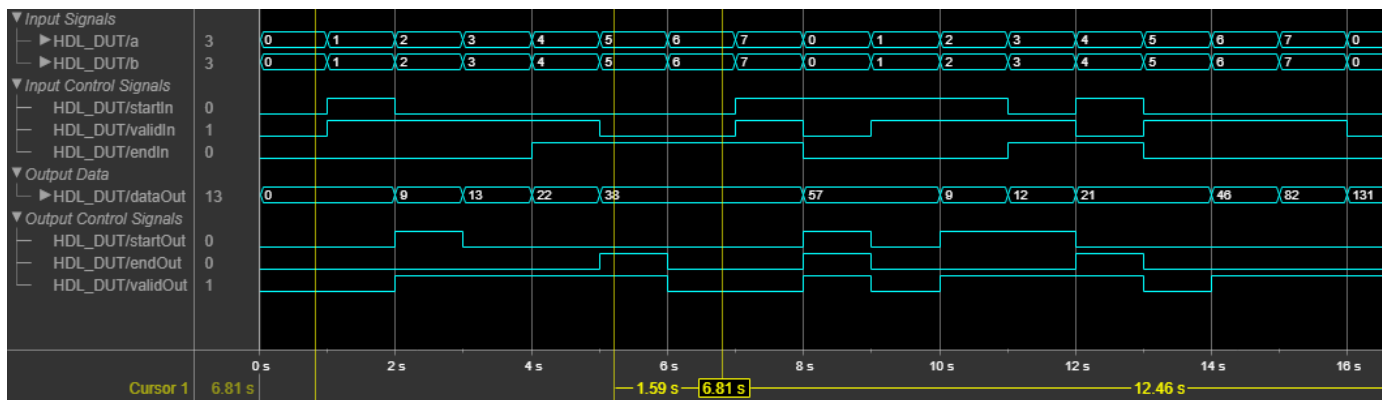

Initially, when **validIn** is low, **dataOut** is zero. At time 1s, both **startIn** and **validIn** become high. Therefore, **validOut** becomes high in the next clock cycle and **dataOut** starts producing valid accumulation output. During accumulation, **dataOut** takes the values of **a** and **b** from the previous clock cycle. For example, at time $t = 2s$, $\mathbf{dataOut} = 1*1 + 8 = 9$.

To continue accumulation, make **startIn** low at the next clock cycle and keep **validIn** high. **dataOut** continues accumulating the inputs until **validIn** becomes low. At each time step, **dataOut** computes the product of the inputs from the previous clock cycle and sums the result with the **dataOut** value from the previous clock cycle. For example, at time $t = 3s$, $\mathbf{dataOut} = 2*2 + 9 = 13$.

When **validIn** becomes low, **dataOut** holds the output value as seen at time $t = 5s$. At $t = 5s$, **endIn** and **validIn** are high. Therefore, **endOut** becomes high in the next clock cycle, which indicates end of frame. Therefore the frame between $t = 2s$ (when **startOut** is high) and $t = 6s$ (when **endOut** is high) indicates a frame containing valid output.

If **startIn**, **validIn**, and **endIn** are both high at the same time, only the **dataOut** corresponding to those inputs are accumulated as seen at $t = 8s$. If **startIn** is high for multiple clock cycles, and if **validIn** is high, the accumulator is reset at each clock cycle as seen at $t = 10s$ and $t = 11s$. The accumulation continues at $t = 12s$.

Streaming Mode Using Number of Samples

You can use the **Operation Mode** setting for the block to specify a streaming mode of operation. When you select **Streaming - using Number of Samples**, you see two additional settings enabled by default. The settings include:

- **Valid output port**
- **Count output port**

It is recommended that you leave these settings enabled. When you apply the settings, you have an additional input port **validIn** and three additional output ports appear:

- **endOut**
- **validOut**
- **countOut**

This figure illustrates the streaming mode of operation using the number of samples. In this example, the bias value is 8 and the **Number of Samples** is 5.

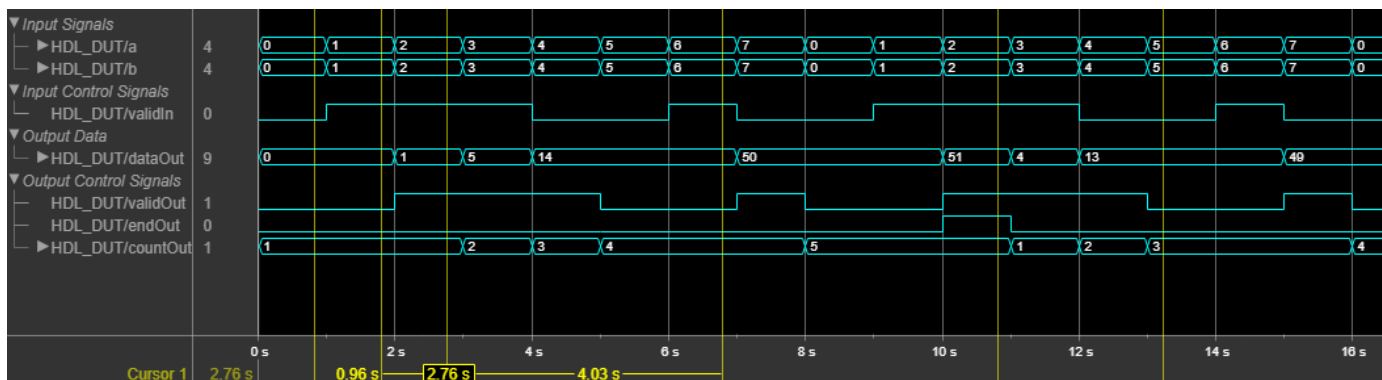

Initially, when **validIn** is low, **dataOut** is 0 and **countOut** is 1. At time 1s, **validIn** becomes high. Therefore, **validOut** becomes high in the next clock cycle, and **dataOut** starts producing valid accumulation output. During accumulation, **dataOut** takes the values of **a** and **b** from the previous clock cycle. For example, at time $t = 2s$, **dataOut** = $1*1 = 1$. **countOut** increments by 1 at the next clock cycle, that is, at $t = 3s$, **countOut** becomes 2.

To continue accumulation, keep **validIn** high. **dataOut** continues accumulating the inputs until **validIn** becomes low. When five valid outputs are obtained from **dataOut**, **countOut** becomes 5 and **endOut** becomes high, which indicates the end of the frame. Therefore, the time between when **countOut** is 1 and when **countOut** is five indicates a frame containing valid output.

The accumulator counter is now reset and **countOut** starts from 1. When **validIn** becomes high again, **dataOut** starts accumulating a new set of values and **countOut** starts incrementing for each valid **dataOut**.

Extended Capabilities

HDL Code Generation

Generate Verilog and VHDL code for FPGA and ASIC designs using HDL Coder™.

HDL Coder provides additional configuration options that affect HDL implementation and synthesized logic.

HDL Architecture

HDL Architecture Setting	Description
Auto (Default)	This mode selects the <code>Serial</code> architecture by default. When the block is inside a feedback loop, the code generator cannot use the <code>Serial</code> architecture if the block is not part of a clock-rate pipelining region and does not have a <code>Delay</code> at the block output. This error occurs because the <code>Serial</code> architecture introduces additional latency which cannot be delay balanced inside the feedback loop. When you use the <code>Auto</code> mode, the code generator switches to the <code>Parallel</code> architecture automatically.
<code>Parallel</code>	For input vectors of size <code>N</code> , this mode uses <code>N</code> <code>Multiply-Add</code> blocks in series to compute the result. This mode uses a combinatorial implementation and does not introduce any latency. If you specify the Synthesis tool and Target frequency , since the adaptive pipelining optimization is enabled, the code generator inserts pipeline registers for the <code>Multiply-Add</code> blocks. When you synthesize your design, depending on the input bit widths, this architecture maps up to <code>N</code> DSP slices on the FPGA.
<code>Serial</code>	<p>For input vectors of size <code>N</code>, this mode uses a streaming algorithm to implement the multiply-accumulate operation. This architecture has two implementation modes:</p> <ul style="list-style-type: none"> The default mode uses a local multirate implementation. This implementation overclocks the shared resources by <code>N</code> and multiplexes the input vectors with a <code>Multiply-Add</code> block. This implementation introduces an additional latency of one at the data rate. If you have clock-rate pipelining enabled on the model or subsystem that contains the <code>Multiply-Accumulate</code> block, this architecture uses a single-rate implementation. This implementation runs the shared resources at the clock-rate and multiplexes the input vectors with a <code>Multiply-Add</code> block. This implementation introduces an additional latency of <code>N</code> at the clock rate. <p>When you synthesize your design, depending on the input bit widths, this architecture maps to one DSP slice on the FPGA.</p>

HDL Block Properties

General	
ConstrainedOutputPipeline	Number of registers to place at the outputs by moving existing delays within your design. Distributed pipelining does not redistribute these registers. The default is 0. For more details, see "ConstrainedOutputPipeline".

General	
InputPipeline	Number of input pipeline stages to insert in the generated code. Distributed pipelining and constrained output pipelining can move these registers. The default is 0. For more details, see "InputPipeline".
OutputPipeline	Number of output pipeline stages to insert in the generated code. Distributed pipelining and constrained output pipelining can move these registers. The default is 0. For more details, see "OutputPipeline".

Complex Data Support

When you use complex signals, this block can generate HDL code, but does not map to DSP slices.

See Also

Dot Product | Multiply-Add

Topics

"Adaptive Pipelining"

"Clock-Rate Pipelining"

Introduced in R2017b

Multiply-Add

Multiply-add combined operation

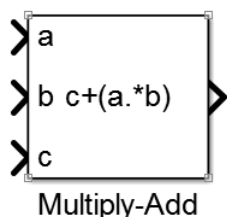

Library

HDL Coder / HDL Operations

Description

The Multiply-Add block computes the product of the first two inputs, a and b, and adds the result to the third input, c. The inputs can be vectors or scalars.

The multiplication operation is full precision, regardless of the output type. The **Integer rounding mode**, **Output data type**, and **Saturate on integer overflow** settings apply only to the addition operation.

Use the Multiply-Add block to map a combined multiply-add or a multiply-subtract operation to a DSP unit in your target hardware. You can select the **Function** setting in the Block Parameters dialog box for the Multiply-Add block.

To map to a DSP unit, specify the `SynthesisTool` property for your model. When you generate HDL code for your model, HDL Coder configures the multiply-add operation so that your synthesis tool can map to a DSP unit.

Note Some DSP units do not have the multiply-add capability. To see if your hardware has the multiply-add capability, refer to the documentation for the hardware.

Data Type Support

The Multiply-Add block accepts and outputs signals of numeric data type that Simulink supports, including fixed-point data types.

You can use matrix data types with the Multiply-Add block. When you use these types, the port dimensions of the inputs a and b must match. For example, in MATLAB, you can perform these matrix operations:

```
a = [1 2; 3 4];
b = [5; 6];
c = 7;

c + (a.*b)
```

```
ans =  
    12    17  
    25    31
```

However, when you perform this multiplication in the Simulink environment, you see an error: **Error in port widths or dimensions.**

See “Data Types Supported by Simulink” (Simulink).

Parameters

Function

Specify the function to perform a combined multiply and add or a multiply and subtract operation.

Settings

Default: `c+(a.*b)`

You can set the function to:

- `c+(a.*b)`
- `c-(a.*b)`
- `(a.*b)-c`

Output data type

Specify the output data type.

Settings

Default: `Inherit: Inherit via internal rule`

Set the output data type to:

- A rule that inherits a data type, for example, `Inherit: Same as input`
- An expression that evaluates to a valid data type, for example, `fixdt([],16,0)`

Click the **Show data type assistant** button  to display the Data Type Assistant dialog box, which helps you to set the **Output data type** parameter.

For more information, see “Control Signal Data Types” (Simulink) in *Simulink User's Guide* (Simulink).

Integer rounding mode

Specify the rounding mode for fixed-point operations.

Settings

Default: `Floor`

Ceiling

Rounds positive and negative numbers toward positive infinity. Equivalent to the MATLAB `ceil` function.

Convergent

Rounds number to the nearest representable value. If a tie occurs, rounds to the nearest even integer. Equivalent to the Fixed-Point Designer `convergent` function.

Floor

Rounds positive and negative numbers toward negative infinity. Equivalent to the MATLAB `floor` function.

Nearest

Rounds number to the nearest representable value. If a tie occurs, rounds toward positive infinity. Equivalent to the Fixed-Point Designer `nearest` function.

Round

Rounds number to the nearest representable value. If a tie occurs, rounds positive numbers toward positive infinity and rounds negative numbers toward negative infinity. Equivalent to the Fixed-Point Designer `round` function.

Simplest

Chooses between rounding toward floor and rounding toward zero to generate rounding code that is as efficient as possible.

Zero

Rounds number toward zero. Equivalent to the MATLAB `fix` function.

Command-Line Information

See “Block-Specific Parameters” (Simulink) for the command-line information.

See Also

For more information, see “Rounding” (Fixed-Point Designer).

Saturate on integer overflow

Specify whether overflows saturate.

Settings

Default: Off

On

Overflows saturate to either the minimum or maximum value that the data type can represent.

For example, an overflow associated with a signed 8-bit integer can saturate to -128 or 127.

Off

Overflows wrap to the appropriate value that the data type can represent.

For example, the number 130 does not fit in a signed 8-bit integer and wraps to -126.

Tips

- Consider selecting this check box when your model has a possible overflow and you want explicit saturation protection in the generated code.
- Consider clearing this check box when you want to optimize efficiency of your generated code.

Clearing this check box also helps you to avoid overspecifying how a block handles out-of-range signals. For more information, see “Troubleshoot Signal Range Errors” (Simulink).

- When you select this check box, saturation applies to every internal operation on the block, not just the output or result.
- In general, the code generation process can detect when overflow is not possible. In this case, the code generator does not produce saturation code.

Command-Line Information

Parameter: SaturateOnIntegerOverflow

Type: character vector

Value: 'off' | 'on'

Default: 'off'

Algorithms**Pipeline Depth**

If you have fixed-point inputs to a Multiply-Add block, you can set the **PipelineDepth** for the block. For floating-point inputs, HDL Coder ignores the **PipelineDepth** parameter and does not insert pipeline registers.

The following diagrams show different configurations of pipeline registers for different synthesis tools and **PipelineDepth** settings. When you specify the **PipelineDepth** setting, HDL Coder inserts pipeline registers so that the configuration maps efficiently to DSP units.

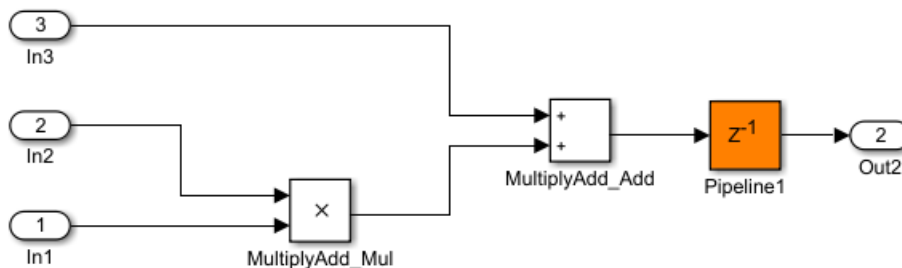
Altera Hardware with PipelineDepth = 1

Altera Hardware with PipelineDepth = 2

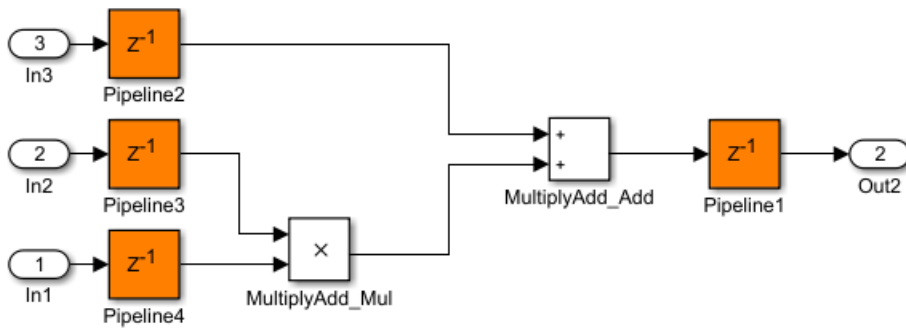

Xilinx Hardware with PipelineDepth = 1

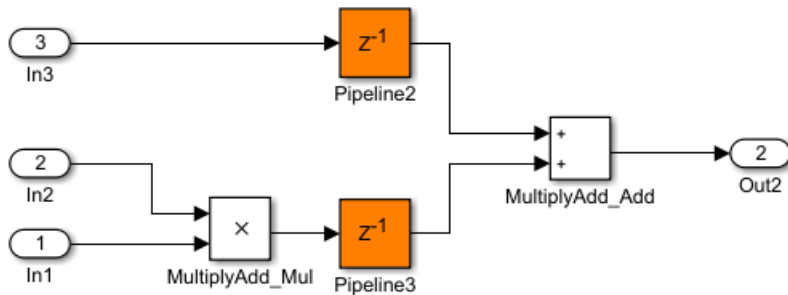

Xilinx Hardware with PipelineDepth = 2

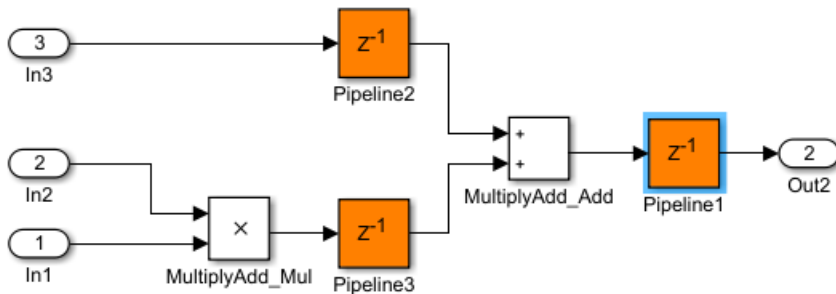

Xilinx Hardware with PipelineDepth = 3

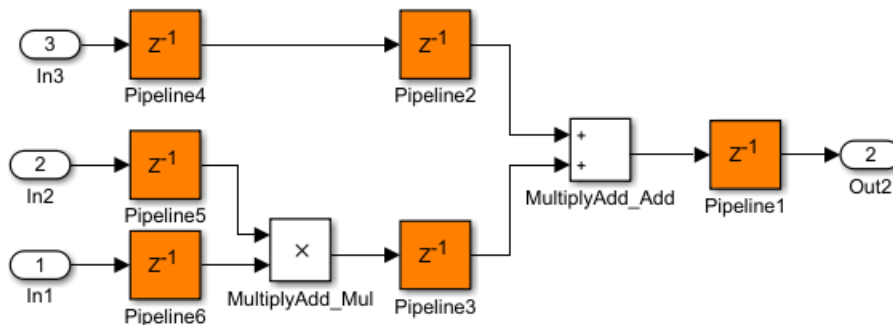

Extended Capabilities

HDL Code Generation

Generate Verilog and VHDL code for FPGA and ASIC designs using HDL Coder™.

HDL Coder provides additional configuration options that affect HDL implementation and synthesized logic.

HDL Architecture

This block has a single, default HDL architecture.

HDL Block Properties

PipelineDepth	<p>Number of pipeline stages. The default is <code>auto</code> which means that the coder determines the number of pipeline stages based on your synthesis tool. For adaptive pipelines to be inserted, when PipelineDepth is set to <code>auto</code>, you must specify the synthesis tool and enter a target frequency value greater than zero.</p> <p>You can enter an integer between 0 and 3. For Altera hardware targets, the maximum pipeline depth is 2.</p>
----------------------	---

General	
HandleDenormals	Specify whether you want HDL Coder to insert additional logic to handle denormal numbers in your design. Denormal numbers are numbers that have magnitudes less than the smallest floating-point number that can be represented without leading zeros in the mantissa. The default is <code>inherit</code> . See also "HandleDenormals".
LatencyStrategy	Specify whether to map the blocks in your design to <code>inherit</code> , <code>Max</code> , <code>Min</code> , or <code>Zero</code> for the floating-point operator. The default is <code>inherit</code> . See also "LatencyStrategy".
MantissaMultiplyStrategy	Specify how to implement the mantissa multiplication operation during code generation. By using different settings, you can control the DSP usage on the target FPGA device. The default is <code>inherit</code> . See also "MantissaMultiplyStrategy".

Complex Data Support

This block supports code generation for complex signals.

Restrictions

- When the block has floating-point inputs, HDL Coder ignores the **PipelineDepth** parameter and does not insert pipeline registers.
- If the block is in a feedback loop and you do not have sufficient delays at the block output, the coder reduces the **PipelineDepth** to prevent delay balancing failure. For sufficient delays, add Delay blocks at the output of the Multiply-Add block.
- To map the combined multiply-add operation to a DSP unit, the width of the third input *c* has to be less than 64 bits for Altera and 48 bits for Xilinx respectively.
- The subtraction operation in the **Function** setting ($a \cdot b$) - *c* does not map to a DSP unit in Altera FPGA libraries.

See Also

Dot Product | Multiply-Accumulate

Topics

“Adaptive Pipelining”

“Clock-Rate Pipelining”

Introduced in R2015b

Resettable Synchronous Subsystem

Represent resettable subsystem that has synchronous reset and enable behavior

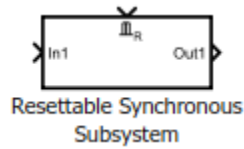

Library

HDL Coder / HDL Subsystems

Description

The Resettable Synchronous Subsystem uses the State Control block in **Synchronous** mode with the Resettable Subsystem block. For subsystem blocks with state, the State Control block in **Synchronous** mode provides efficient reset and enable simulation behavior on hardware.

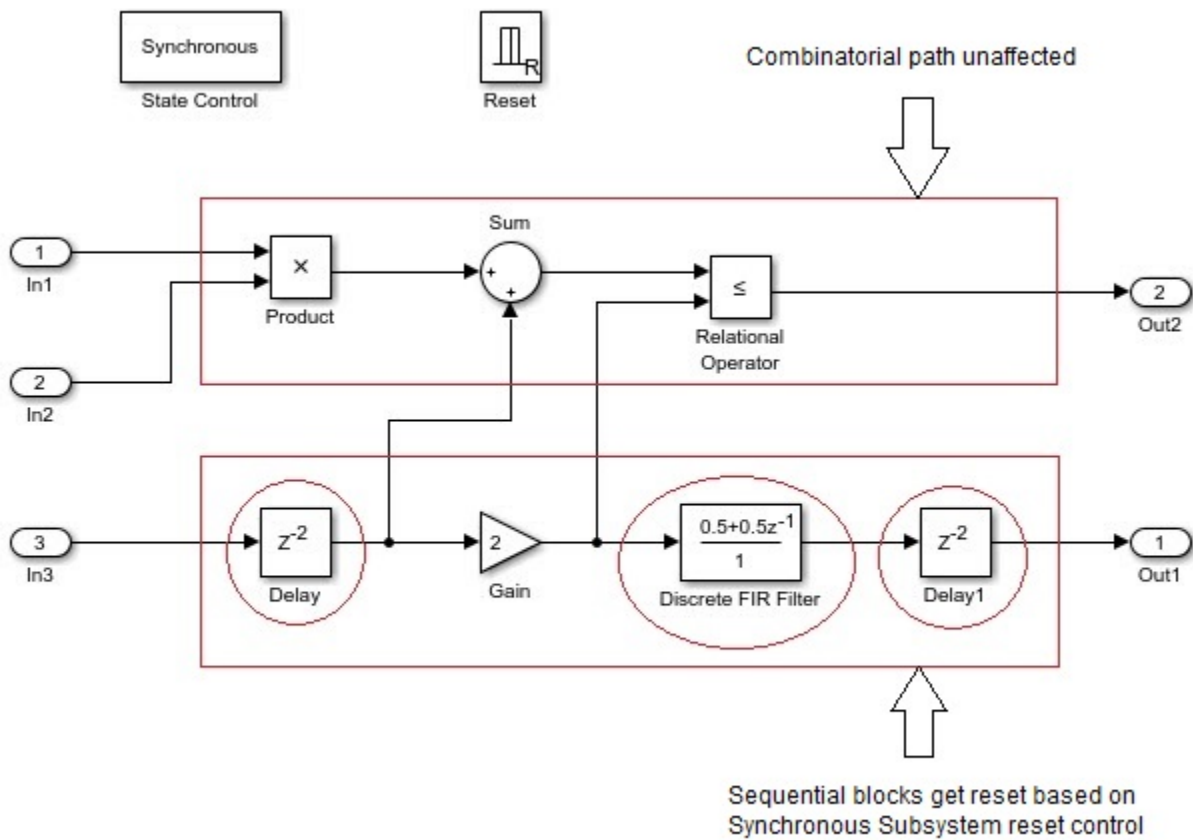

The reset port in the Resettable Synchronous Subsystem block adds reset capability to blocks inside the subsystem that have state. This includes blocks that need not have an external reset port capability, such as filters, Stateflow® Chart, and MATLAB Function blocks. For HDL code generation, the **Reset trigger type** of the Reset port is set to `level_hold` by default.

Data Type Support

See `Inport` for information on the data types accepted by a subsystem's input ports. See `Outport` for information on the data types output by a subsystem's output ports.

For more information, see “Data Types Supported by Simulink” (Simulink) in the Simulink documentation.

Parameters

Show port labels

Display subsystem port labels on the subsystem block.

Settings

Default: `FromPortIcon`

`none`

Does not display port labels on the subsystem block.

`FromPortIcon`

If the corresponding port icon displays a signal name, the parameter displays the signal name on the subsystem block. Otherwise, it displays the port block name.

`FromPortBlockName`

Display the name of the corresponding port block on the subsystem block.

`SignalName`

If the signal connected to the subsystem block port is named, this parameter displays the name. Otherwise, it displays the name of the corresponding port block.

Command-Line Information

See “Block-Specific Parameters” (Simulink) for the command-line information.

Read/Write permissions

Control user access to the contents of the subsystem.

Settings

Default: `ReadWrite`

`ReadWrite`

Enables opening and modification of subsystem contents.

`ReadOnly`

Enables the opening but not modification of the subsystem. If the subsystem resides in a block library, you can create and open links to the subsystem, and create and modify local copies of the

subsystem. You cannot change the permissions or modify the contents of the original library instance.

NoReadOrWrite

Disables the opening or modification of subsystem. If the subsystem resides in a block library, you can create links to the subsystem in a model. You cannot open, modify, change permissions, or create local copies of the subsystem.

Command-Line Information

See “Block-Specific Parameters” (Simulink) for the command-line information.

Name of error callback function

Enter the name of the function to be called if an error occurs while Simulink software is executing the subsystem.

Settings

Default: ' '

Simulink passes two arguments to the function: the subsystem handle and a character vector that specifies the error type. If no function is specified, you get a generic error message.

Command-Line Information

See “Block-Specific Parameters” (Simulink) for the command-line information.

Permit hierarchical resolution

Specify whether to resolve names of workspace variables referenced by this subsystem.

Settings

Default: All

All

Resolve all names of workspace variables used by this subsystem, including those used to specify block parameter values and Simulink data objects (for example, `Simulink.Signal` objects).

ExplicitOnly

Resolve the names of workspace variables used to specify block parameter values, data store memory (where no block exists), signals, and states marked by using the signal resolution icon.

None

Do not resolve workspace variable names.

Command-Line Information

See “Block-Specific Parameters” (Simulink) for the command-line information.

Treat as atomic unit

Causes Simulink to treat the subsystem as a unit when determining the execution order of block methods.

Settings**Default:** Off On

Cause Simulink to treat the subsystem as a unit when determining the execution order of block methods. For example, when it needs to compute the output of the subsystem, Simulink software invokes the output methods of all the blocks in the subsystem before invoking the output methods of other blocks at the same level as the subsystem block.

 Off

Cause Simulink to treat all blocks in the subsystem as being at the same level in the model hierarchy as the subsystem when determining block method execution order. This can cause the execution of block methods in the subsystem to be interleaved with the execution of block methods outside the subsystem.

Dependencies

This parameter enables:

- **Minimize algebraic loop occurrences**
- **Sample time**
- **Function packaging** (requires a Simulink Coder license)

Command-Line Information

See “Block-Specific Parameters” (Simulink) for the command-line information.

Treat as grouped when propagating variant conditions

Causes Simulink software to treat the subsystem as a unit when propagating variant conditions from Variant Source blocks or to Variant Sink blocks.

Settings**Default:** On On

Simulink treats the subsystem as a unit when propagating variant conditions from Variant Source blocks or to Variant Sink blocks. For example, when Simulink computes the variant condition of the subsystem, it propagates that condition to all blocks in the subsystem.

 Off

Simulink treats all blocks in the subsystem as being at the same level in the model hierarchy as the subsystem itself when determining their variant condition.

Command-Line Information

See “Block-Specific Parameters” (Simulink) for the command-line information.

Function packaging

Specify the code format to be generated for an atomic (nonvirtual) subsystem.

Settings**Default:** Auto**Auto**

Simulink Coder chooses the optimal format based on the type and number of subsystem instances in the model.

Inline

Simulink Coder inlines the subsystem unconditionally.

Nonreusable function

Simulink Coder software explicitly generates a separate function in a separate file. Subsystems with this setting generate functions that might have arguments depending on the **Function interface** parameter setting. You can name the generated function and file using parameters **Function name** and **File name (no extension)**. These functions are not reentrant.

Reusable function

Simulink Coder generates a function with arguments that allows reuse of subsystem code when a model includes multiple instances of the subsystem.

This option generates a function with arguments that allows subsystem code to be reused in the generated code of a model reference hierarchy. In this case, the subsystem must be in a library.

Command-Line Information

See “Block-Specific Parameters” (Simulink) for the command-line information.

Characteristics

Data Types	Double Single Boolean Base Integer Fixed-Point Enumerated Bus
Multidimensional Signals	Yes
Variable-Size Signals	Yes
HDL Code Generation	Yes

Extended Capabilities**C/C++ Code Generation**

Generate C and C++ code using Simulink® Coder™.

Actual code generation support depends on block implementation.

HDL Code Generation

Generate Verilog and VHDL code for FPGA and ASIC designs using HDL Coder™.

HDL Coder provides additional configuration options that affect HDL implementation and synthesized logic.

HDL Architecture

Architecture	Description
Module (default)	Generate code for the subsystem and the blocks within the subsystem.
BlackBox	Generate a black box interface. The generated HDL code includes only the input/output port definitions for the subsystem. Therefore, you can use a subsystem in your model to generate an interface to existing, manually written HDL code. The black-box interface generation for subsystems is similar to the Model block interface generation without the clock signals.
No HDL	Remove the subsystem from the generated code. You can use the subsystem in simulation, however, treat it as a “no-op” in the HDL code.

Black Box Interface Customization

For the BlackBox architecture, you can customize port names and set attributes of the external component interface. See “Customize Black Box or HDL Cosimulation Interface”.

HDL Block Properties

General	
AdaptivePipelining	Automatic pipeline insertion based on the synthesis tool, target frequency, and multiplier word-lengths. The default is <code>inherit</code> . See also “AdaptivePipelining”.
BalanceDelays	Detects introduction of new delays along one path and inserts matching delays on the other paths. The default is <code>inherit</code> . See also “BalanceDelays”.
ClockRatePipelining	Insert pipeline registers at a faster clock rate instead of the slower data rate. The default is <code>inherit</code> . See also “ClockRatePipelining”.
ConstrainedOutputPipeline	Number of registers to place at the outputs by moving existing delays within your design. Distributed pipelining does not redistribute these registers. The default is <code>0</code> . For more details, see “ConstrainedOutputPipeline”.
DistributedPipelining	Pipeline register distribution, or register retiming. The default is <code>off</code> . See also “DistributedPipelining”.
DSPStyle	Synthesis attributes for multiplier mapping. The default is <code>none</code> . See also “DSPStyle”.
FlattenHierarchy	Remove subsystem hierarchy from generated HDL code. The default is <code>inherit</code> . See also “FlattenHierarchy”.
InputPipeline	Number of input pipeline stages to insert in the generated code. Distributed pipelining and constrained output pipelining can move these registers. The default is <code>0</code> . For more details, see “InputPipeline”.
OutputPipeline	Number of output pipeline stages to insert in the generated code. Distributed pipelining and constrained output pipelining can move these registers. The default is <code>0</code> . For more details, see “OutputPipeline”.
SharingFactor	Number of functionally equivalent resources to map to a single shared resource. The default is <code>0</code> . See also “Resource Sharing”.

General	
StreamingFactor	Number of parallel data paths, or vectors, that are time multiplexed to transform into serial, scalar data paths. The default is 0, which implements fully parallel data paths. See also "Streaming".

If this block is not the DUT, the block property settings in the **Target Specification** tab are ignored. In the HDL Workflow Advisor, if you use the **IP Core Generation** workflow, these target specification block property values are saved with the model. If you specify these target specification block property values using `hdlset_param`, when you open HDL Workflow Advisor, the fields are populated with the corresponding values.

Target Specification	
AdditionalTargetInterfaces	<p>Additional target interfaces, specified as a character vector.</p> <p>To save this block property on the model, in the Set Target Interface task of the IP Core Generation workflow, corresponding to the DUT ports that you want to add more interfaces, select Add more... You can then add more interfaces in the Add New Target Interfaces dialog box. Specify the type of interface, number of additional interfaces, and a unique name for each additional interface.</p> <p>Values: ' ' (default) cell array of character vectors</p> <p>Example: <code>'{{'AXI4-Stream', 'InterfaceID', 'AXI4-Stream1'}}'</code></p>
ProcessorFPGASynchronization	<p>Processor/FPGA synchronization mode, specified as a character vector.</p> <p>To save this block property on the model, specify the Processor/FPGA Synchronization in the Set Target Interface task of the IP Core Generation workflow.</p> <p>Values: Free running (default) Coprocessing - blocking</p> <p>Example: 'Free running'</p>
TestPointMapping	<p>To save this block property on the model, specify the mapping of test point ports to target platform interfaces in the Set Target Interface task of the IP Core Generation workflow.</p> <p>Values: ' ' (default) cell array of character vectors</p> <p>Example: <code>'{{'TestPoint', 'AXI4-Lite', 'x"108" '}}'</code></p>
TunableParameterMapping	<p>To save this block property on the model, specify the mapping of tunable parameter ports to target platform interfaces in the Set Target Interface task of the IP Core Generation workflow.</p> <p>Values: ' ' (default) cell array of character vectors</p> <p>Example: <code>'{{'myParam', 'AXI4-Lite', 'x"108" '}}'</code></p>

Target Specification	
AXI4RegisterReadback	<p>To save this block property on the model, specify whether you want to enable readback on AXI4 slave write registers in the Generate RTL Code and IP Core task of the IP Core Generation workflow. To learn more, see “Model Design for AXI4 Slave Interface Generation”.</p> <p>Values: 'off' (default) 'on'</p>
AXI4SlaveIDWidth	<p>To save this block property on the model, specify the number of AXI Master interfaces that you want to connect the DUT IP core to by using the AXI4 Slave ID Width setting in the Generate RTL Code and IP Core task of the IP Core Generation workflow. To learn more, see “Define Multiple AXI Master Interfaces in Reference Designs to access DUT AXI4 Slave Interface”.</p> <p>Values: 'off' (default) 'on'</p>
AXI4SlavePortToPipelineRegisterRatio	<p>To save this block property on the model, specify the number of AXI4 slave ports for which you want a pipeline register to be inserted by using the AXI4 Slave port to pipeline register ratio setting in the Generate RTL Code and IP Core task of the IP Core Generation workflow. To learn more, see “Model Design for AXI4 Slave Interface Generation”.</p> <p>Values: 'off' (default) 'on'</p>
GenerateDefaultAXI4 Slave	<p>To save this block property on the model, specify whether you want to disable generation of default AXI4 slave interfaces in the Generate RTL Code and IP Core task of the IP Core Generation workflow.</p> <p>Values: 'on' (default) 'off'</p>
IPCoreAdditionalFiles	<p>Verilog or VHDL files for black boxes in your design. Specify the full path to each file, and separate file names with a semicolon (;).</p> <p>You can set this property in the HDL Workflow Advisor, in the Additional source files field.</p> <p>Values: '' (default) character vector</p> <p>Example: 'C:\myprojfiles \led_blinking_file1.vhd;C:\myprojfiles \led_blinking_file2.vhd;'</p>
IPCoreName	<p>IP core name, specified as a character vector.</p> <p>You can set this property in the HDL Workflow Advisor, in the IP core name field. If this property is set to the default value, the HDL Workflow Advisor constructs the IP core name based on the name of the DUT.</p> <p>Values: '' (default) character vector</p> <p>Example: 'my_model_name'</p>

Target Specification	
IPCoreVersion	<p>IP core version number, specified as a character vector.</p> <p>You can set this property in the HDL Workflow Advisor, in the IP core version field. If this property is set to the default value, the HDL Workflow Advisor sets the IP core version.</p> <p>Values: ' ' (default) character vector</p> <p>Example: '1.3'</p>
IPDataCaptureBuffer Size	<p>FPGA Data Capture buffer size, specified as a character vector. Use FPGA Data Capture to observe signals in a design when running on an FPGA.</p> <p>The buffer size uses values that are $128 \cdot 2^n$, where n is an integer. By default, the buffer size is 128 ($n=0$). The maximum value of n is 13, which means that the maximum value for buffer size is 1048576 ($=128 \cdot 2^{13}$).</p> <p>Values: ' ' (default) character vector</p> <p>Example: '1.3'</p>

Restrictions

- You cannot use the State Control block in **Classic** mode or remove the State Control block from the Resettable Synchronous Subsystem block.
- The **Reset trigger type** of the Reset port inside the subsystem must be set to `level_hold`.
- A Delay block with nonvirtual bus input signals inside a Resettable Synchronous Subsystem is not supported if you enable optimizations on the subsystem.
- HDL Coder does not support these blocks inside a Resettable Synchronous Subsystem:
 - All RAM blocks or blocks that infer a RAM in the generated HDL code. The RAM blocks include:
 - Single Port RAM
 - Simple Dual Port RAM
 - Dual Port RAM
 - Dual Rate Dual Port RAM
 - HDL FIFO
 - `hdl.RAM` system object

DSP System Toolbox

- Biquad Filter
- NCO HDL Optimized

Communications Toolbox

- Convolutional Encoder
- Viterbi Decoder
- PN Sequence Generator

- Integer-Output RS Decoder HDL Optimized

Vision HDL Toolbox

- Demosaic Interpolator
- Edge Detector
- Histogram
- Image Filter, Median Filter, Bilateral Filter
- Line Memory
- Binary and Grayscale Morphology blocks
- Pixel Stream FIFO

Wireless HDL Toolbox

- LTE Turbo Decoder and LTE Turbo Encoder
- LTE Convolutional Encoder
- LTE OFDM Demodulator and LTE OFDM Modulator
- NR Polar Encoder and NR Polar Decoder
- Viterbi Decoder
- FFT 1536
- RS Decoder
- OFDM Channel Estimator
- NR LDPC Encoder and NR LDPC Decoder

See Also

Enabled Synchronous Subsystem | State Control | Synchronous Subsystem

Topics

“Resettable Subsystem Support in HDL Coder™”

“Using the State Control block to generate more efficient code with HDL Coder™”

“Synchronous Subsystem Behavior with the State Control Block”

Introduced in R2016b

Serializer1D

Convert vector signal to scalar or smaller vectors

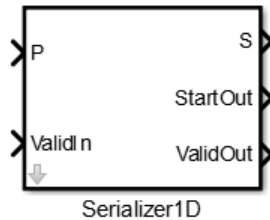

Library

HDL Coder / HDL Operations

Description

The Serializer1D block converts a slower vector signal into a faster stream of scalar signals or smaller size vector signals based on the **Ratio** and **Idle Cycle** values. To match the faster serialized output, the sample time changes according to this equation:

$$\text{Output Sample Time} = \text{Input Sample Time} / (\text{Ratio} + \text{Idle Cycles})$$

Consider this example where the input data is a vector of size 4 and the **Ratio** is set to 4.

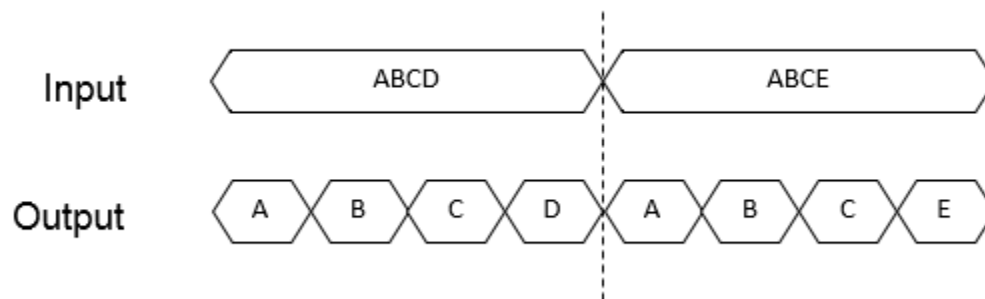

The output data serializes each of the vector signals into four scalar signals. The sample time at the output is: $\text{Output Sample Time} = \text{Input Sample Time} / 4$.

To add idle cycles at the end of each output, for **Idle Cycles**, specify an integer greater than zero. Consider this example with **Ratio** set to 4 and **Idle Cycles** set to 2.

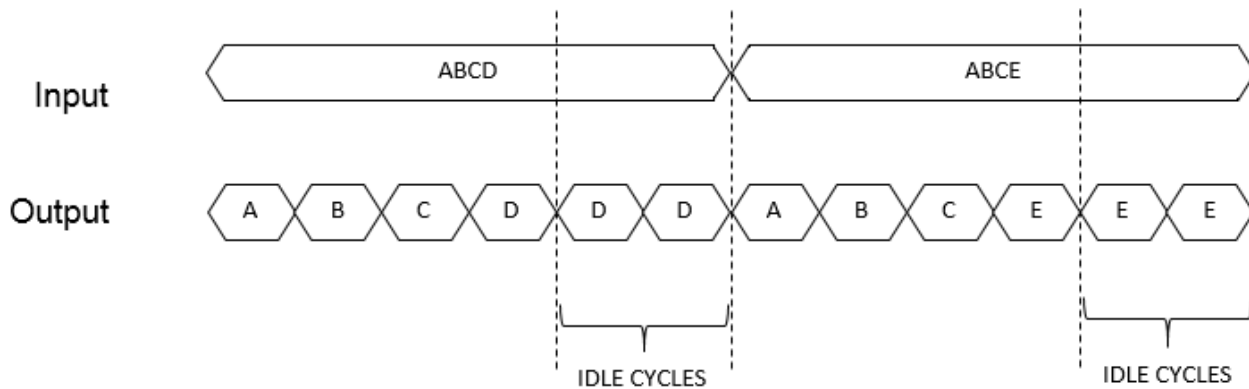

For each slow vector signal, the output has six fast cycles consisting of the four serialized scalar signals and two idle cycles. The sample time at the output is $Output\ Sample\ Time = Input\ Sample\ Time/6$.

The Serializer1D block provides three control signals: **ValidIn**, **ValidOut**, and **StartOut**. You can use **ValidIn** to control **ValidOut** and **StartOut**. The serialized output does not depend on **ValidIn**. To determine whether the output serialized data is valid, use **ValidIn** and **ValidOut**. If you give a high input to **ValidIn**, and there are no idle cycles, **ValidOut** gives a high output, which indicates that the output serialized data is valid.

Consider an example that has input data as a vector of size 4, **Ratio** set to 4, **Idle Cycles** set to 2, and uses all three control signals.

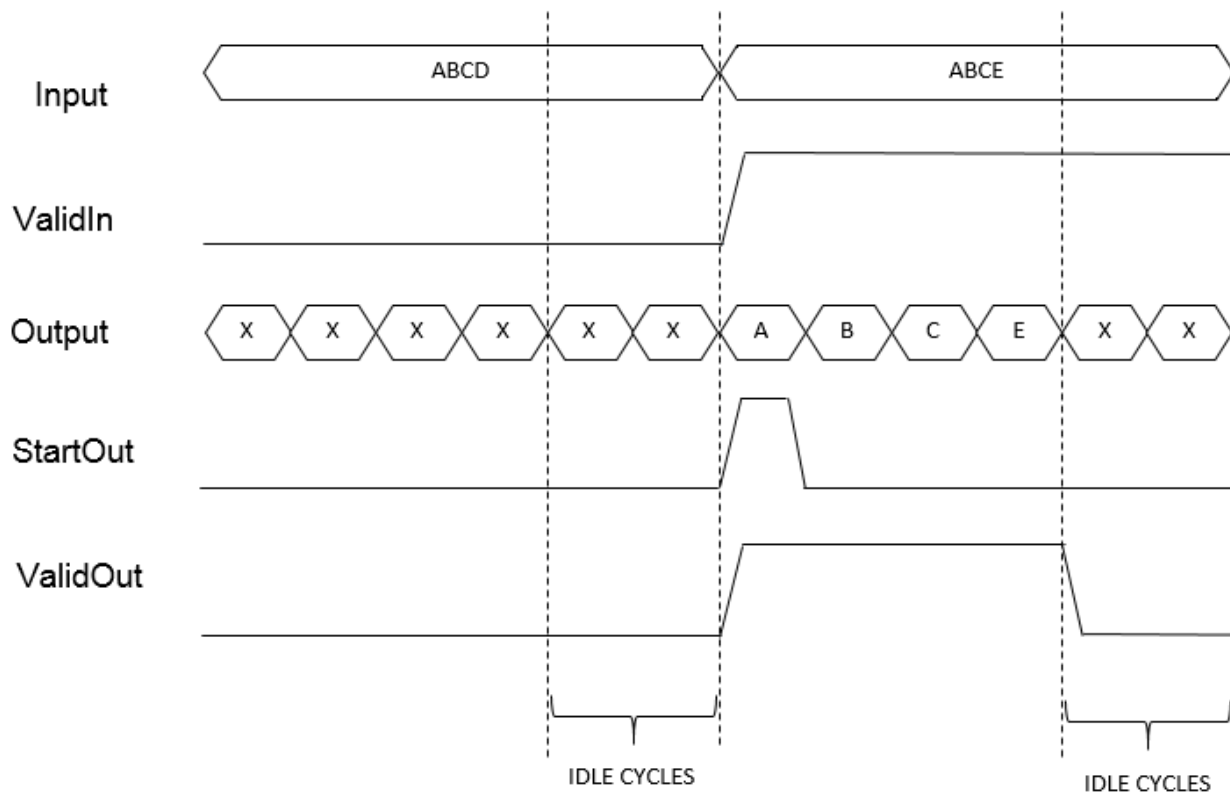

For the first input vector, ABCD, **ValidIn** is false. **StartOut** and **ValidOut** become false. This means that the output data values are not valid. In the waveform, the data values are represented as X, which correspond to *don't care* values.

For the second input vector, ABCE, **ValidIn** is true. The output data serializes the vector into four scalar signals. The control signal **StartOut** becomes true at output A to indicate the start of deserialization. In the next cycle, the **StartOut** signal becomes false. **ValidOut** is true for all four output signals indicating valid output data for the four cycles. **ValidOut** becomes false for the idle cycles, and the output data values are *don't care* values.

Parameters

Ratio

Serialization factor, specified as a positive scalar. Default is 1.

The ratio is equal to the size of the input vector divided by the size of the output vector. Input vector size must be divisible by the ratio.

Idle Cycles

Number of idle cycles to add at the end of each output. Default is 0.

ValidIn

Activates the **ValidIn** port. Default is off.

StartOut

Activates the **StartOut** port. Default is `off`.

ValidOut

Activates the **ValidOut** port. Default is `off`.

Input data port dimensions (-1 for inherited)

Size of the input data signal. Input vector size must be divisible by the ratio. By default, the block inherits size based on the context within the model.

Input sample time (-1 for inherited)

Time interval between sample time hits, or another appropriate sample time such as continuous. By default, the block inherits sample time based on context within the model. For more information, see “Sample Time” (Simulink).

Input signal type

Input signal type of the block, specified as `auto`, `real`, or `complex`. Default is `auto`.

Ports

P

Input signal to serialize. Bus data types are not supported.

ValidIn

Input control signal. This port is available when you select the **ValidIn** check box.

Data type: Boolean

S

Serialized output signal. Bus data types are not supported.

StartOut

Output control signal that indicates where to start deserialization. You can use this signal as the **StartIn** input to the Deserializer1D block. To use this port, select the **StartOut** check box.

Data type: Boolean

ValidOut

Output control signal that indicates valid output signal. You can use this signal as the **ValidIn** input to the Deserializer1D block. This port is available when you select the **ValidOut** check box.

Data type: Boolean

Extended Capabilities**HDL Code Generation**

Generate Verilog and VHDL code for FPGA and ASIC designs using HDL Coder™.

HDL Coder provides additional configuration options that affect HDL implementation and synthesized logic.

HDL Architecture

Note For simulation results that match the generated HDL code, in the Solver pane of the Configuration Parameters dialog box, clear the checkbox for **Treat each discrete rate as a**

separate task. When the checkbox is cleared, single-tasking mode is enabled. If you simulate the block with this check box selected, the output data can update in the same cycle but in the generated HDL code, the output data is updated one cycle later.

This block has a single, default HDL architecture.

HDL Block Properties

General	
ConstrainedOutputPipeline	Number of registers to place at the outputs by moving existing delays within your design. Distributed pipelining does not redistribute these registers. The default is 0. For more details, see "ConstrainedOutputPipeline".
InputPipeline	Number of input pipeline stages to insert in the generated code. Distributed pipelining and constrained output pipelining can move these registers. The default is 0. For more details, see "InputPipeline".
OutputPipeline	Number of output pipeline stages to insert in the generated code. Distributed pipelining and constrained output pipelining can move these registers. The default is 0. For more details, see "OutputPipeline".

See Also

Deserializer1D

Introduced in R2014b

Simple Dual Port RAM

Dual port RAM with single output port

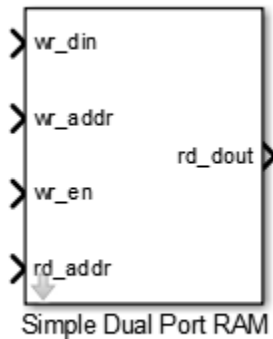

Library

HDL Coder / HDL RAMs

Description

The Simple Dual Port RAM block models RAM that supports simultaneous read and write operations, and has a single output port for read data. You can use this block to generate HDL code that maps to RAM in most FPGAs.

The Simple Dual Port RAM is similar to the Dual Port RAM, but the Dual Port RAM has both a write data output port and a read data output port.

Read-During-Write Behavior

During a write operation, if a read operation occurs at the same address, old data appears at the output.

Parameters

Address port width

Address bit width. Minimum bit width is 2, and maximum bit width is 29. The default is 8.

Ports

The block has the following ports:

`wr_din`

Write data input. The data can have any width. It inherits the width and data type from the input signal.

Data type: scalar fixed point, integer, or complex

`wr_addr`

Write address.

Data type: scalar unsigned integer (`uintN`) or unsigned fixed point (`ufixN`) with a fraction length of 0

`wr_en`

Write enable.

Data type: Boolean

`rd_addr`

Read address.

Data type: scalar unsigned integer (`uintN`) or unsigned fixed point (`ufixN`) with a fraction length of 0

`rd_dout`

Output data from read address, `rd_addr`.

Algorithms

HDL code generated for RAM blocks has:

- A latency of one clock cycle for read data output.
- No reset signal, because some synthesis tools do not infer a RAM from HDL code if it includes a reset.

Code generation for a RAM block creates a separate file, *blockname.ext*. *blockname* is derived from the name of the RAM block. *ext* is the target language file name extension.

RAM Initialization

Code generated to initialize a RAM is intended for simulation only. Synthesis tools can ignore this code.

Implement RAM With or Without Clock Enable

The HDL block property, `RAMArchitecture`, enables or suppresses generation of clock enable logic for all RAM blocks in a subsystem. You can set `RAMArchitecture` to the following values:

- `WithClockEnable` (default): Generates RAM using HDL templates that include a clock enable signal, and an empty RAM wrapper.
- `WithoutClockEnable`: Generates RAM without clock enables, and a RAM wrapper that implements the clock enable logic.

Some synthesis tools do not infer RAM with a clock enable. If your synthesis tool does not support RAM structures with a clock enable, and cannot map your generated HDL code to FPGA RAM resources, set `RAMArchitecture` to `WithoutClockEnable`.

To learn how to generate RAM without clock enables for your design, see the Getting Started with RAM and ROM example. To open the example, at the command prompt, enter:

hdlcoderramrom

RAM Inference Limitations

If you use RAM blocks to perform concurrent read and write operations, verify the read-during-write behavior in hardware. The read-during-write behavior of the RAM blocks in Simulink matches that of the generated behavioral HDL code. However, if a synthesis tool does not follow the same behavior during RAM inference, it causes the read-during-write behavior in hardware to differ from the behavior of the Simulink model or generated HDL code.

Your synthesis tool might not map the generated code to RAM for the following reasons:

- Small RAM size: your synthesis tool uses registers to implement a small RAM for better performance.
- A clock enable signal is present. You can suppress generation of a clock enable signal in RAM blocks, as described in “Implement RAM With or Without Clock Enable” on page 3-94.

Extended Capabilities

HDL Code Generation

Generate Verilog and VHDL code for FPGA and ASIC designs using HDL Coder™.

HDL Coder provides additional configuration options that affect HDL implementation and synthesized logic.

HDL Architecture

This block has a single, default HDL architecture.

HDL Block Properties

General	
ConstrainedOutputPipeline	Number of registers to place at the outputs by moving existing delays within your design. Distributed pipelining does not redistribute these registers. The default is 0. For more details, see “ConstrainedOutputPipeline”.
InputPipeline	Number of input pipeline stages to insert in the generated code. Distributed pipelining and constrained output pipelining can move these registers. The default is 0. For more details, see “InputPipeline”.
OutputPipeline	Number of output pipeline stages to insert in the generated code. Distributed pipelining and constrained output pipelining can move these registers. The default is 0. For more details, see “OutputPipeline”.
RAMDirective	Specify whether to map RAM blocks in your design to distributed RAMs, block RAMs, or UltraRAM memory on the target FPGA. See also “RAMDirective”.

Complex Data Support

This block supports code generation for complex signals.

See Also

Blocks

Dual Port RAM | Dual Rate Dual Port RAM | Single Port RAM

Introduced in R2014a

Simple Dual Port RAM System

Simple Dual Port RAM block based on the `hdl.RAM` system object with ability to provide initial value

Library: HDL Coder / HDL RAMs

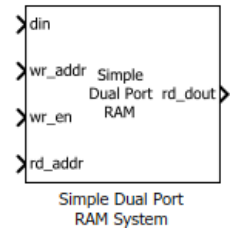

Description

The blocks are MATLAB System blocks that use the `hdl.RAM` System object. You can specify the RAM type as `Dual port`, `Simple dual port`, or `Single port`. In terms of simulation behavior, the Dual Port RAM System block behaves similar to the Dual Port RAM, the Single Port RAM System behaves similar to the Single Port RAM, and so on. With the MATLAB System blocks, you can:

- Specify an initial value for the RAM. In the Block Parameters dialog box, enter a value for **Specify the RAM initial value**.
- Obtain faster simulation results when you use these blocks in your Simulink model.
- Create parallel RAM banks when you use vector data by leveraging the `hdl.RAM` System object functionality.
- Obtain higher performance and support for large data memories.

Limitations

- The block does not support boolean inputs. Cast any boolean types to `ufix1` for input to the block.
- When you build the FPGA bitstream for the RAM, the global reset logic does not reset the RAM contents. To reset the RAM, make sure that you implement the reset logic.
- The RAM write address can be either `fixed-point (fi)` or `integer`, must be unsigned, and must be between 2 and 31 bits long.

Ports

Input

din — Write data input

Scalar (default) | Vector

Data that you write into the RAM memory location when `wrEn` is true. This value can be `double`, `single`, `integer`, or a `fixed-point (fi)` object, and can be real or complex.

Data Types: `single` | `double` | `int8` | `int16` | `uint8` | `uint16` | `fixed point`

wr_addr — Write address

Scalar (default) | Vector

RAM address that you write the data into. This value can be either `fixed-point (fi)` or `integer`, must be unsigned, and must be between 2 and 31 bits long.

Dependencies

To enable this port, set the **Specify the type of RAM** parameter to `Simple dual port` or `Dual port`.

Data Types: `uint8` | `uint16` | `fixed point`

wr_en — Write enable

`Scalar (default)` | `Vector`

When `wrEn` is true, the RAM writes the data into the memory location that you specify. If you set the **Specify the type of RAM** to `Single port`, the RAM reads the value in the memory location `addr` when `wrEn` is false.

Data Types: `Boolean`

rd_addr — Read address

`Scalar (default)` | `Vector`

Address that you read the data from the RAM. This value can be either `fixed-point (fi)` or `integer`, and must be real and unsigned.

Dependencies

To enable this port, set the **Specify the type of RAM** parameter to `Simple dual port` or `Dual port`.

Data Types: `uint8` | `uint16` | `fixed point`

Output**rd_dout — Read data**

`Scalar (default)` | `Vector`

Old output data that the RAM reads from the memory location `rd_addr`.

Dependencies

To enable this port, set the **Specify the type of RAM** parameter to `Simple dual port` or `Dual port`.

Parameters**Specify the type of RAM — RAM type**

`Dual port (default)` | `Simple dual port` | `Single port`

Type of RAM, specified as either:

- `Single port` — Create a single port RAM with Write data, Address, and Write enable as inputs and Read data as the output.
- `Simple dual port` — Create a simple dual port RAM with Write data, Write address, Write enable, and Read address as inputs and data from read address as the output.
- `Dual port` — Create a dual port RAM with Write data, Write address, Write enable, and Read address as inputs and data from read address and write address as the outputs.

The code generator dynamically configures the input and output ports of the block based on the RAM type that you specify.

Specify the output data for a write operation — Write output behavior

New data (default) | Old data

Behavior for Write output, specified as either:

- 'New data' — Send out new data at the address to the output.
- 'Old data' — Send out old data at the address to the output.

Specify the RAM initial value — Initial simulation output of RAM

'0.0' (default) | Scalar | Vector

Initial simulation output of the System object, specified as either:

- A scalar value.
- A vector with one-to-one mapping between the initial value and the RAM words.

Extended Capabilities

HDL Code Generation

Generate Verilog and VHDL code for FPGA and ASIC designs using HDL Coder™.

HDL Coder provides additional configuration options that affect HDL implementation and synthesized logic.

HDL Architecture

The block has a MATLABSystem architecture which indicates that the block implementation uses thehdl.RAM System object.

HDL Block Properties

General	
ConstrainedOutputPipeline	Number of registers to place at the outputs by moving existing delays within your design. Distributed pipelining does not redistribute these registers. The default is 0. For more details, see "ConstrainedOutputPipeline".
InputPipeline	Number of input pipeline stages to insert in the generated code. Distributed pipelining and constrained output pipelining can move these registers. The default is 0. For more details, see "InputPipeline".
OutputPipeline	Number of output pipeline stages to insert in the generated code. Distributed pipelining and constrained output pipelining can move these registers. The default is 0. For more details, see "OutputPipeline".
RAMDirective	Specify whether to map RAM blocks in your design to distributed RAMs, block RAMs, or UltraRAM memory on the target FPGA. For UltraRAM mapping, Specify the RAM initial value must be set to 0. See also "RAMDirective".

Complex Data Support

This block supports code generation for complex signals.

See Also

System Objects

hdl.RAM

Blocks

Dual Port RAM System | Single Port RAM System

Topics

“HDL Code Generation from hdl.RAM System Object”

“Getting Started with RAM and ROM in Simulink®”

“Implement RAM Using MATLAB Code”

“HDL Code Generation for System Objects”

Introduced in R2017b

Sine HDL Optimized

Implement fixed-point sine wave by using lookup table approach optimized for HDL code generation

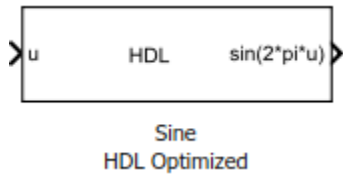

Library

HDL Coder / Lookup Tables

Description

The Sine HDL Optimized block implements a fixed-point sine wave by using a lookup table method that exploits quarter-wave symmetry.

For the most efficient HDL implementation, configure the block with an exact power of two as the number of elements. In the Block Parameters dialog box, for **Number of data points**, specify an integer that is an exact power of two. That is, specify the lookup table data points to be (2^n) , where n is an integer. By default, the **Number of data points** is 64.

When you specify a power of two for the **Number of data points**, the lookup tables precede a register without reset after HDL code generation. The combination of the lookup table block and register without reset maps efficiently to RAM on the target device.

Depending on your selection of the **Output formula** parameter, the blocks can output these functions of the input signal:

- $\sin(2\pi u)$
- $\cos(2\pi u)$
- $\exp(i2\pi u)$
- $\sin(2\pi u)$ and $\cos(2\pi u)$

Use the **Table data type** parameter to specify the word length of the fixed-point output data type. The fraction length of the output is the output word length minus 2.

Data Type Support

The Sine HDL Optimized block accepts signals of these data types:

- Floating point
- Built-in integer
- Fixed point
- Boolean

The output of the block is a fixed-point data type.

For more information, see “Data Types Supported by Simulink” (Simulink) in the Simulink documentation.

Parameters

Output formula

Select the signal(s) to output.

Number of data points

Specify the number of data points to retrieve from the lookup table. The implementation is most efficient when you specify the lookup table data points to be (2^n) , where n is an integer.

Table data type

Specify the table data type. You can specify an expression that evaluates to a data type, for example, `fixdt(1,16,0)`.

Click the **Show data type assistant** button  to display the **Data Type Assistant**, which helps you set the table data type.

Show data type assistant

Display the **Data Type Assistant**. In the **Data Type Assistant**, you can select the mode to specify the data type.

Mode

Select the mode of data type specification. If you select **Expression**, enter an expression that evaluates to a data type, for example, `fixdt(1,16,0)`.

If you select **Fixed point**, you can use the options in the **Data Type Assistant** to specify the fixed-point data type. In the **Fixed point** mode, you can choose binary point scaling, and specify the signedness, word length, fraction length, and the data type override setting.

Characteristics

Data Types	Double Single Boolean Base Integer Fixed-Point
Sample Time	Inherited from driving block
Direct Feedthrough	Yes
Multidimensional Signals	No
Variable-Size Signals	No
Zero-Crossing Detection	No
Code Generation	Yes

Extended Capabilities

HDL Code Generation

Generate Verilog and VHDL code for FPGA and ASIC designs using HDL Coder™.

HDL Coder provides additional configuration options that affect HDL implementation and synthesized logic.

HDL Architecture

The HDL code implements the Sine HDL Optimized block by using the quarter-wave lookup table that you specify in the Simulink block parameters.

HDL Block Properties

General	
ConstrainedOutputPipeline	Number of registers to place at the outputs by moving existing delays within your design. Distributed pipelining does not redistribute these registers. The default is 0. For more details, see "ConstrainedOutputPipeline".
InputPipeline	Number of input pipeline stages to insert in the generated code. Distributed pipelining and constrained output pipelining can move these registers. The default is 0. For more details, see "InputPipeline".
OutputPipeline	Number of output pipeline stages to insert in the generated code. Distributed pipelining and constrained output pipelining can move these registers. The default is 0. For more details, see "OutputPipeline".

See Also

Cosine HDL Optimized | Sine, Cosine | Trigonometric Function

Introduced in R2016b

Single Port RAM

Single port RAM

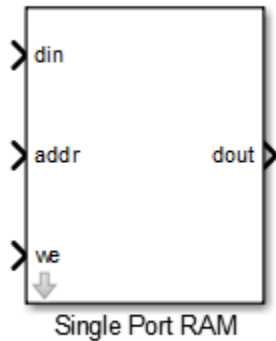

Library

HDL Coder / HDL RAMs

Description

The Single Port RAM block models RAM that supports sequential read and write operations.

If you want to model RAM that supports simultaneous read and write operations, use the Dual Port RAM or Simple Dual Port RAM.

Parameters

Address port width

Address bit width. Minimum bit width is 2, and maximum bit width is 29. The default is 8.

Output data during write

Controls the output data, `dout`, during a write access.

- `New data` (default): During a write, new data appears at the output port, `dout`.
- `Old data`: During a write, old data appears at the output port, `dout`.

Ports

The block has the following ports:

`din`

Data input. The data can have any width. It inherits the width and data type from the input signal.

Data type: scalar fixed point, integer, or complex

addr

Write address.

Data type: scalar unsigned integer (`uintN`) or unsigned fixed point (`ufixN`) with a fraction length of 0

we

Write enable.

Data type: Boolean

dout

Output data from address, `addr`.

Algorithms

HDL code generated for RAM blocks has:

- A latency of one clock cycle for read data output.
- No reset signal, because some synthesis tools do not infer a RAM from HDL code if it includes a reset.

Code generation for a RAM block creates a separate file, *blockname.ext*. *blockname* is derived from the name of the RAM block. *ext* is the target language file name extension.

RAM Initialization

Code generated to initialize a RAM is intended for simulation only. Synthesis tools can ignore this code.

Implement RAM With or Without Clock Enable

The HDL block property, `RAMArchitecture`, enables or suppresses generation of clock enable logic for all RAM blocks in a subsystem. You can set `RAMArchitecture` to the following values:

- `WithClockEnable` (default): Generates RAM using HDL templates that include a clock enable signal, and an empty RAM wrapper.
- `WithoutClockEnable`: Generates RAM without clock enables, and a RAM wrapper that implements the clock enable logic.

Some synthesis tools do not infer RAM with a clock enable. If your synthesis tool does not support RAM structures with a clock enable, and cannot map your generated HDL code to FPGA RAM resources, set `RAMArchitecture` to `WithoutClockEnable`.

To learn how to generate RAM without clock enables for your design, see the Getting Started with RAM and ROM example. To open the example, at the command prompt, enter:

```
hdlcoderramrom
```

RAM Inference Limitations

Depending on your synthesis tool and target device, the setting of **Output data during write** can affect RAM inference.

If you use RAM blocks to perform concurrent read and write operations, verify the read-during-write behavior in hardware. The read-during-write behavior of the RAM blocks in Simulink matches that of the generated behavioral HDL code. However, if a synthesis tool does not follow the same behavior during RAM inference, it causes the read-during-write behavior in hardware to differ from the behavior of the Simulink model or generated HDL code.

Your synthesis tool might not map the generated code to RAM for the following reasons:

- Small RAM size: your synthesis tool uses registers to implement a small RAM for better performance.
- A clock enable signal is present. You can suppress generation of a clock enable signal in RAM blocks, as described in “Implement RAM With or Without Clock Enable” on page 3-105.

Extended Capabilities

HDL Code Generation

Generate Verilog and VHDL code for FPGA and ASIC designs using HDL Coder™.

HDL Coder provides additional configuration options that affect HDL implementation and synthesized logic.

HDL Architecture

This block has a single, default HDL architecture.

HDL Block Properties

General	
ConstrainedOutputPipeline	Number of registers to place at the outputs by moving existing delays within your design. Distributed pipelining does not redistribute these registers. The default is 0. For more details, see “ConstrainedOutputPipeline”.
InputPipeline	Number of input pipeline stages to insert in the generated code. Distributed pipelining and constrained output pipelining can move these registers. The default is 0. For more details, see “InputPipeline”.
OutputPipeline	Number of output pipeline stages to insert in the generated code. Distributed pipelining and constrained output pipelining can move these registers. The default is 0. For more details, see “OutputPipeline”.
RAMDirective	Specify whether to map RAM blocks in your design to distributed RAMs, block RAMs, or UltraRAM memory on the target FPGA. See also “RAMDirective”.

Complex Data Support

This block supports code generation for complex signals.

See Also

Blocks

Dual Port RAM | Dual Rate Dual Port RAM | Simple Dual Port RAM

Introduced in R2014a

Single Port RAM System

Single Port RAM block based on hdl.RAM system object with ability to provide initial value

Library: HDL Coder / HDL RAMs

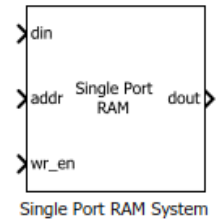

Description

The blocks are MATLAB System blocks that use the `hdl.RAM System` object. You can specify the RAM type as `Dual port`, `Simple dual port`, or `Single port`. In terms of simulation behavior, the Single Port RAM System block behaves similar to the Single Port RAM.

By using the MATLAB System block implementation, you can:

- Specify an initial value for the RAM. In the Block Parameters dialog box, enter a value for **Specify the RAM initial value**.
- Obtain faster simulation results when you use these blocks in your Simulink model.
- Create parallel RAM banks when you use vector data by leveraging the `hdl.RAM System` object functionality.
- Obtain higher performance and support for large data memories.

Limitations

- The block does not support `boolean` inputs. Cast any `boolean` types to `ufix1` for input to the block.
- When you build the FPGA bitstream for the RAM, the global reset logic does not reset the RAM contents. To reset the RAM, make sure that you implement the reset logic.
- The RAM address can be either `fixed-point (fi)` or `integer`, must be unsigned, and must be between 2 and 31 bits long.

Ports

Input

din — Write data input

Scalar (default) | Vector

Data that you write into the RAM memory location when `wrEn` is true. This value can be `double`, `single`, `integer`, or a `fixed-point (fi)` object, and can be real or complex.

Data Types: `single` | `double` | `int8` | `int16` | `uint8` | `uint16` | `fixed point`

addr — Write or Read address

Scalar (default) | Vector

Address that you write the data into when `wrEn` is true. The RAM reads the value in memory location `addr` when `wrEn` is false. This value can be either `fixed-point (fi)` or `integer`, must be unsigned, and must be between 2 and 31 bits long.

Dependencies

To enable this port, set the **Specify the type of RAM** parameter to `Single port`.

Data Types: `uint8` | `uint16` | `fixed point`

`wr_en` — Write enable

Scalar (default) | Vector

When `wrEn` is true, the RAM writes the data into the memory location that you specify. If you set the **Specify the type of RAM** to `Single port`, the RAM reads the value in the memory location `addr` when `wrEn` is false.

Data Types: `Boolean`

Output

`dout` — Output data

Scalar (default) | Vector

Output data that the RAM reads from the memory location `addr` when `wrEn` is false.

Dependencies

To enable this port, set the **Specify the type of RAM** parameter to `Single port`.

Parameters

Specify the type of RAM — RAM type

`Dual port` (default) | `Simple dual port` | `Single port`

Type of RAM, specified as either:

- `Single port` — Create a single port RAM with Write data, Address, and Write enable as inputs and Read data as the output.
- `Simple dual port` — Create a simple dual port RAM with Write data, Write address, Write enable, and Read address as inputs and data from read address as the output.
- `Dual port` — Create a dual port RAM with Write data, Write address, Write enable, and Read address as inputs and data from read address and write address as the outputs.

The code generator dynamically configures the input and output ports of the block based on the RAM type that you specify.

Specify the output data for a write operation — Write output behavior

`New data` (default) | `Old data`

Behavior for Write output, specified as either:

- `'New data'` — Send out new data at the address to the output.
- `'Old data'` — Send out old data at the address to the output.

Specify the RAM initial value – Initial simulation output of RAM

'0.0' (default) | Scalar | Vector

Initial simulation output of the System object, specified as either:

- A scalar value.
- A vector with one-to-one mapping between the initial value and the RAM words.

Extended Capabilities**HDL Code Generation**

Generate Verilog and VHDL code for FPGA and ASIC designs using HDL Coder™.

HDL Coder provides additional configuration options that affect HDL implementation and synthesized logic.

HDL Architecture

The block has a MATLABSystem architecture which indicates that the block implementation uses the hdl.RAM System object.

HDL Block Properties

General	
ConstrainedOutputPipeline	Number of registers to place at the outputs by moving existing delays within your design. Distributed pipelining does not redistribute these registers. The default is 0. For more details, see “ConstrainedOutputPipeline”.
InputPipeline	Number of input pipeline stages to insert in the generated code. Distributed pipelining and constrained output pipelining can move these registers. The default is 0. For more details, see “InputPipeline”.
OutputPipeline	Number of output pipeline stages to insert in the generated code. Distributed pipelining and constrained output pipelining can move these registers. The default is 0. For more details, see “OutputPipeline”.
RAMDirective	Specify whether to map RAM blocks in your design to distributed RAMs, block RAMs, or UltraRAM memory on the target FPGA. For UltraRAM mapping, Specify the RAM initial value must be set to 0. See also “RAMDirective”.

Complex Data Support

This block supports code generation for complex signals.

See Also**System Objects**

hdl.RAM

Blocks

Dual Port RAM System | Simple Dual Port RAM

Topics

“HDL Code Generation from hdl.RAM System Object”

“Getting Started with RAM and ROM in Simulink®”

“Implement RAM Using MATLAB Code”

“HDL Code Generation for System Objects”

Introduced in R2017b

State Control

Specify synchronous reset and enable behavior for blocks with state

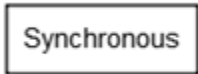

Library

HDL Coder / HDL Subsystems

Description

Use the State Control block to toggle subsystem behavior between the default Simulink simulation behavior and the synchronous hardware simulation behavior.

- For default Simulink simulation behavior, set **State control** to **Classic**. The simulation behavior in **Classic** mode is the same as when you do not use the State Control block inside the subsystem.
- For synchronous hardware simulation behavior, set **State control** to **Synchronous**. The State Control block in **Synchronous** mode improves the HDL simulation behavior of blocks with state, or blocks that have reset or enable ports. When use the **Synchronous** mode of the block, the generated HDL code uses fewer hardware resources and the Simulink simulation behavior closely matches that of the digital hardware.

See “Synchronous Subsystem Behavior with the State Control Block”.

Parameters

State control

Specify whether to use synchronous or classic semantics. The default is **Synchronous**.

Limitations

Subsystem-level Limitations

- Conditional subsystems using classic semantics cannot have subsystems with synchronous semantics inside them.
- You cannot flatten a synchronous subsystem up into a classic system.
- Conditional subsystems must be single rate when you use the State Control block in synchronous mode.
- Synchronous Enabled Subsystem cannot contain reset subsystems or a reset parameter port. For example, you cannot have a Delay block with an external reset port inside the subsystem.
- All action subsystems connected to If and Switch Case blocks must have the same semantics, either classic or synchronous.
- These blocks are not supported in synchronous mode:

- For Iterator Subsystem
- While Iterator Subsystem
- Function-Call Subsystem
- Triggered Subsystem

Model-Level Limitations

- Variable-size signals are not supported with synchronous semantics.
- Synchronous semantics do not propagate across model boundaries. If your parent model has synchronous semantics, any referenced model must have synchronous semantics explicitly specified. At the root level of each referenced model, add a State Control block with the **State control** parameter set to Synchronous.

Supported Block Modes

The following restrictions apply to blocks in synchronous mode:

- Delay block: When you have an external reset port, set the **External reset** to Level hold.
- The method `ssSetStateSemanticsClassicAndSynchronous` must be set to `true`.
- Stateflow Chart: Set the **State Machine Type** to Moore.
- MATLAB Function block:
 - You cannot have System Objects inside the MATLAB Function block.
 - If you use nondirect feedthrough in a MATLAB Function block, do not program the outputs to rely on inputs or updated persistent variables. The MATLAB Function block must drive the outputs from persistent variables.

To use nondirect feedthrough, in the Ports and Data Manager, clear the **Allow direct feedthrough** check box. See “Use Nondirect Feedthrough in a MATLAB Function Block” (Simulink).

Unsupported Blocks

The following blocks are not allowed in synchronous mode:

- The set of unit delay blocks in the **Additional Math & Discrete > Additional Discrete** sublibrary in Simulink, such as the Unit Delay Resettable and Unit Delay External IC blocks
- Simulink blocks with **Input processing** set to Columns as channels (frame based), where this parameter applies.
- Continuous time blocks and blocks with continuous rate
- Discrete-Time Integrator with reset port
- From Workspace
- Trigger
- LMS Filter
- HDL Minimum Resource FFT
- DC Blocker
- PN Sequence Generator
- Convolutional Interleaver and Convolutional Deinterleaver

- General Multiplexed Interleaver and General Multiplexed Deinterleaver
- Convolutional Encoder and Viterbi Decoder
- Sample and Hold

Extended Capabilities

HDL Code Generation

Generate Verilog and VHDL code for FPGA and ASIC designs using HDL Coder™.

HDL Coder provides additional configuration options that affect HDL implementation and synthesized logic.

HDL Architecture

This block has a single, default HDL architecture. HDL Coder does not generate HDL code specific to the State Control block. How you set the State Control block affects other blocks inside the subsystem that have state.

See Also

Blocks

Enable | Enabled Subsystem | Enabled Synchronous Subsystem | Resettable Synchronous Subsystem

Topics

“Using the State Control block to generate more efficient code with HDL Coder™”

“Resettable Subsystem Support in HDL Coder™”

“Synchronous Subsystem Behavior with the State Control Block”

Introduced in R2016a

Synchronous Subsystem

Represent subsystem that has synchronous reset and enable behavior



Library

HDL Coder / HDL Subsystems

Description

A Synchronous Subsystem is a subsystem that uses the Synchronous mode of the State Control block. If an **S** symbol appears in the subsystem, then it is synchronous.

To create a Synchronous Subsystem, add the block to your Simulink model from the HDL Subsystems block library. You can also add a State Control block with **State control** set to Synchronous inside a subsystem.

Data Type Support

See Inport for information on the data types accepted by a subsystem's input ports. See Outport for information on the data types output by a subsystem's output ports.

For more information, see “Data Types Supported by Simulink” (Simulink) in the Simulink documentation.

Parameters

Show port labels

Cause Simulink software to display labels for the subsystem's ports on the subsystem's icon.

Settings

Default: FromPortIcon

none

Does not display port labels on the subsystem block.

FromPortIcon

If the corresponding port icon displays a signal name, display the signal name on the subsystem block. Otherwise, display the port block's name.

FromPortBlockName

Display the name of the corresponding port block on the subsystem block.

SignalName

If a name exists, display the name of the signal connected to the port on the subsystem block; otherwise, the name of the corresponding port block.

Command-Line Information

See “Block-Specific Parameters” (Simulink) for the command-line information.

Read/Write permissions

Control user access to the contents of the subsystem.

Settings

Default: ReadWrite

ReadWrite

Enables opening and modification of subsystem contents.

ReadOnly

Enables opening but not modification of the subsystem. If the subsystem resides in a block library, you can create and open links to the subsystem and can make and modify local copies of the subsystem but cannot change the permissions or modify the contents of the original library instance.

NoReadOrWrite

Disables opening or modification of subsystem. If the subsystem resides in a library, you can create links to the subsystem in a model but cannot open, modify, change permissions, or create local copies of the subsystem.

Command-Line Information

See “Block-Specific Parameters” (Simulink) for the command-line information.

Name of error callback function

Enter name of a function to be called if an error occurs while Simulink software is executing the subsystem.

Settings

Default: ' '

Simulink software passes two arguments to the function: the handle of the subsystem and a character vector that specifies the error type. If no function is specified, Simulink software displays a generic error message if executing the subsystem causes an error.

Command-Line Information

See “Block-Specific Parameters” (Simulink) for the command-line information.

Permit hierarchical resolution

Specify whether to resolve names of workspace variables referenced by this subsystem.

Settings

Default: All

All

Resolve all names of workspace variables used by this subsystem, including those used to specify block parameter values and Simulink data objects (for example, `Simulink.Signal` objects).

ExplicitOnly

Resolve only names of workspace variables used to specify block parameter values, data store memory (where no block exists), signals, and states marked as “must resolve”.

None

Do not resolve workspace variable names.

Command-Line Information

See “Block-Specific Parameters” (Simulink) for the command-line information.

Treat as atomic unit

Causes Simulink software to treat the subsystem as a unit when determining the execution order of block methods.

Settings

Default: Off

On

Cause Simulink software to treat the subsystem as a unit when determining the execution order of block methods. For example, when it needs to compute the output of the subsystem, Simulink software invokes the output methods of all the blocks in the subsystem before invoking the output methods of other blocks at the same level as the subsystem block.

Off

Cause Simulink software to treat all blocks in the subsystem as being at the same level in the model hierarchy as the subsystem when determining block method execution order. This can cause execution of methods of blocks in the subsystem to be interleaved with execution of methods of blocks outside the subsystem.

Dependencies

This parameter enables:

- **Minimize algebraic loop occurrences**
- **Sample time**
- **Function packaging** (requires a Simulink Coder license)

Command-Line Information

See “Block-Specific Parameters” (Simulink) for the command-line information.

Treat as grouped when propagating variant conditions

Causes Simulink software to treat the subsystem as a unit when propagating variant conditions from Variant Source blocks or to Variant Sink blocks.

Settings

Default: On

On

Simulink treats the subsystem as a unit when propagating variant conditions from Variant Source blocks or to Variant Sink blocks. For example, when Simulink computes the variant condition of the subsystem, it propagates that condition to all the blocks in the subsystem.

Off

Simulink treats all blocks in the subsystem as being at the same level in the model hierarchy as the subsystem itself when determining their variant condition.

Dependency

Treat as grouped when propagating variant conditions enables this parameter.

Command-Line Information

See “Block-Specific Parameters” (Simulink) for the command-line information.

Function packaging

Specify the code format to be generated for an atomic (nonvirtual) subsystem.

Settings

Default: Auto

Auto

Simulink Coder software chooses the optimal format for you based on the type and number of instances of the subsystem that exist in the model.

Inline

Simulink Coder software inlines the subsystem unconditionally.

Nonreusable function

Simulink Coder software explicitly generates a separate function in a separate file. Subsystems with this setting generate functions that might have arguments depending on the **Function interface** parameter setting. You can name the generated function and file using parameters **Function name** and **File name (no extension)**. These functions are not reentrant.

Reusable function

Simulink Coder software generates a function with arguments that allows reuse of subsystem code when a model includes multiple instances of the subsystem.

This option also generates a function with arguments that allows subsystem code to be reused in the generated code of a model reference hierarchy that includes multiple instances of a subsystem across referenced models. In this case, the subsystem must be in a library.

Command-Line Information

See “Block-Specific Parameters” (Simulink) for the command-line information.

Characteristics

Data Types	Double Single Boolean Base Integer Fixed-Point Enumerated Bus
------------	---

Multidimensional Signals	Yes
Variable-Size Signals	Yes
HDL Code Generation	Yes

Extended Capabilities

C/C++ Code Generation

Generate C and C++ code using Simulink® Coder™.

Actual code generation support depends on block implementation.

HDL Code Generation

Generate Verilog and VHDL code for FPGA and ASIC designs using HDL Coder™.

HDL Coder provides additional configuration options that affect HDL implementation and synthesized logic.

HDL Architecture

Architecture	Description
Module (default)	Generate code for the subsystem and the blocks within the subsystem.
BlackBox	Generate a black box interface. The generated HDL code includes only the input/output port definitions for the subsystem. Therefore, you can use a subsystem in your model to generate an interface to existing, manually written HDL code. The black-box interface generation for subsystems is similar to the Model block interface generation without the clock signals.
No HDL	Remove the subsystem from the generated code. You can use the subsystem in simulation, however, treat it as a “no-op” in the HDL code.

Black Box Interface Customization

For the BlackBox architecture, you can customize port names and set attributes of the external component interface. See “Customize Black Box or HDL Cosimulation Interface”.

HDL Block Properties

General	
AdaptivePipelining	Automatic pipeline insertion based on the synthesis tool, target frequency, and multiplier word-lengths. The default is <code>inherit</code> . See also “AdaptivePipelining”.
BalanceDelays	Detects introduction of new delays along one path and inserts matching delays on the other paths. The default is <code>inherit</code> . See also “BalanceDelays”.
ClockRatePipelining	Insert pipeline registers at a faster clock rate instead of the slower data rate. The default is <code>inherit</code> . See also “ClockRatePipelining”.

General	
ConstrainedOutputPipeline	Number of registers to place at the outputs by moving existing delays within your design. Distributed pipelining does not redistribute these registers. The default is 0. For more details, see “ConstrainedOutputPipeline”.
DistributedPipelining	Pipeline register distribution, or register retiming. The default is off. See also “DistributedPipelining”.
DSPStyle	Synthesis attributes for multiplier mapping. The default is none. See also “DSPStyle”.
FlattenHierarchy	Remove subsystem hierarchy from generated HDL code. The default is inherit. See also “FlattenHierarchy”.
InputPipeline	Number of input pipeline stages to insert in the generated code. Distributed pipelining and constrained output pipelining can move these registers. The default is 0. For more details, see “InputPipeline”.
OutputPipeline	Number of output pipeline stages to insert in the generated code. Distributed pipelining and constrained output pipelining can move these registers. The default is 0. For more details, see “OutputPipeline”.
SharingFactor	Number of functionally equivalent resources to map to a single shared resource. The default is 0. See also “Resource Sharing”.
StreamingFactor	Number of parallel data paths, or vectors, that are time multiplexed to transform into serial, scalar data paths. The default is 0, which implements fully parallel data paths. See also “Streaming”.

If this block is not the DUT, the block property settings in the **Target Specification** tab are ignored. In the HDL Workflow Advisor, if you use the **IP Core Generation** workflow, these target specification block property values are saved with the model. If you specify these target specification block property values using `hdlset_param`, when you open HDL Workflow Advisor, the fields are populated with the corresponding values.

Target Specification	
AdditionalTargetInterfaces	<p>Additional target interfaces, specified as a character vector.</p> <p>To save this block property on the model, in the Set Target Interface task of the IP Core Generation workflow, corresponding to the DUT ports that you want to add more interfaces, select Add more... You can then add more interfaces in the Add New Target Interfaces dialog box. Specify the type of interface, number of additional interfaces, and a unique name for each additional interface.</p> <p>Values: '' (default) cell array of character vectors</p> <p>Example: '{{'AXI4-Stream', 'InterfaceID', 'AXI4-Stream1'}}'</p>

Target Specification	
ProcessorFPGASynchronization	<p>Processor/FPGA synchronization mode, specified as a character vector.</p> <p>To save this block property on the model, specify the Processor/FPGA Synchronization in the Set Target Interface task of the IP Core Generation workflow.</p> <p>Values: Free running (default) Coprocessing - blocking</p> <p>Example: 'Free running'</p>
TestPointMapping	<p>To save this block property on the model, specify the mapping of test point ports to target platform interfaces in the Set Target Interface task of the IP Core Generation workflow.</p> <p>Values: '' (default) cell array of character vectors</p> <p>Example: '{'TestPoint', 'AXI4-Lite', 'x"108"'}'</p>
TunableParameterMapping	<p>To save this block property on the model, specify the mapping of tunable parameter ports to target platform interfaces in the Set Target Interface task of the IP Core Generation workflow.</p> <p>Values: '' (default) cell array of character vectors</p> <p>Example: '{'myParam', 'AXI4-Lite', 'x"108"'}'</p>
AXI4RegisterReadback	<p>To save this block property on the model, specify whether you want to enable readback on AXI4 slave write registers in the Generate RTL Code and IP Core task of the IP Core Generation workflow. To learn more, see "Model Design for AXI4 Slave Interface Generation".</p> <p>Values: 'off' (default) 'on'</p>
AXI4SlaveIDWidth	<p>To save this block property on the model, specify the number of AXI Master interfaces that you want to connect the DUT IP core to by using the AXI4 Slave ID Width setting in the Generate RTL Code and IP Core task of the IP Core Generation workflow. To learn more, see "Define Multiple AXI Master Interfaces in Reference Designs to access DUT AXI4 Slave Interface".</p> <p>Values: 'off' (default) 'on'</p>
AXI4SlavePortToPipelineRegisterRatio	<p>To save this block property on the model, specify the number of AXI4 slave ports for which you want a pipeline register to be inserted by using the AXI4 Slave port to pipeline register ratio setting in the Generate RTL Code and IP Core task of the IP Core Generation workflow. To learn more, see "Model Design for AXI4 Slave Interface Generation".</p> <p>Values: 'off' (default) 'on'</p>
GenerateDefaultAXI4Slave	<p>To save this block property on the model, specify whether you want to disable generation of default AXI4 slave interfaces in the Generate RTL Code and IP Core task of the IP Core Generation workflow.</p> <p>Values: 'on' (default) 'off'</p>

Target Specification	
IPCoreAdditionalFiles	<p>Verilog or VHDL files for black boxes in your design. Specify the full path to each file, and separate file names with a semicolon (;).</p> <p>You can set this property in the HDL Workflow Advisor, in the Additional source files field.</p> <p>Values: ' ' (default) character vector</p> <p>Example: 'C:\myprojfiles \led_blinking_file1.vhd;C:\myprojfiles \led_blinking_file2.vhd;'</p>
IPCoreName	<p>IP core name, specified as a character vector.</p> <p>You can set this property in the HDL Workflow Advisor, in the IP core name field. If this property is set to the default value, the HDL Workflow Advisor constructs the IP core name based on the name of the DUT.</p> <p>Values: ' ' (default) character vector</p> <p>Example: 'my_model_name'</p>
IPCoreVersion	<p>IP core version number, specified as a character vector.</p> <p>You can set this property in the HDL Workflow Advisor, in the IP core version field. If this property is set to the default value, the HDL Workflow Advisor sets the IP core version.</p> <p>Values: ' ' (default) character vector</p> <p>Example: '1.3'</p>
IPDataCaptureBuffer Size	<p>FPGA Data Capture buffer size, specified as a character vector. Use FPGA Data Capture to observe signals in a design when running on an FPGA.</p> <p>The buffer size uses values that are $128 \cdot 2^n$, where n is an integer. By default, the buffer size is 128 ($n=0$). The maximum value of n is 13, which means that the maximum value for buffer size is 1048576 ($=128 \cdot 2^{13}$).</p> <p>Values: ' ' (default) character vector</p> <p>Example: '1.3'</p>

Restrictions

If your DUT is a masked subsystem, you can generate code only if it is at the top level of the model.

See Also

Enabled Synchronous Subsystem | Resettable Synchronous Subsystem | State Control

Topics

“Resettable Subsystem Support in HDL Coder™”

“Using the State Control block to generate more efficient code with HDL Coder™”

“Synchronous Subsystem Behavior with the State Control Block”

Introduced in R2016a

Unit Delay Enabled Synchronous

Delay input signal by one sample period when external Enable signal is true

Library: HDL Coder / Discrete

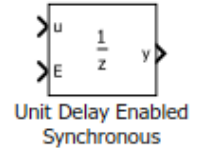

Description

The Unit Delay Enabled Synchronous block delays the input signal u by one sample period when the external Enable signal is true. When the Enable signal is false, the state and output signal hold the previous value. The Enable signal is true when E is not zero and false when E is zero.

The Unit Delay Enabled Synchronous block implementation consists of a Synchronous Subsystem that contains an Enabled Delay block with a **Delay length** of one and a State Control block in Synchronous mode. When you use this block in your model and have HDL Coder installed, your model generates cleaner HDL code and uses fewer hardware resources due to the Synchronous behavior of the State Control block.

Limitations

- The block does not support vector inputs on the Enable port.
- You cannot use the block inside Enabled Subsystem, Triggered Subsystem, or Resettable Subsystem blocks that use Classic semantics. The Subsystem must use Synchronous semantics.

Ports

Input

u — Input signal

Scalar | Vector | Matrix | Array | Bus

The Unit Delay Enabled Synchronous block accepts the input signal of the data types listed below. For more information, see “Data Types Supported by Simulink” (Simulink).

Data Types: single | double | int8 | int16 | int32 | uint8 | uint16 | uint32 | Boolean | fixed point | enumerated | bus

Input

E — Enable signal

Scalar

The Unit Delay Enabled Synchronous block accepts the Enable signal of the data types listed below. For more information, see “Data Types Supported by Simulink” (Simulink).

Data Types: single | double | int8 | int16 | int32 | uint8 | uint16 | uint32 | Boolean | fixed point

Output

y — Output signal

Scalar | Vector | Matrix | Array | Bus

Output data type matches input.

Data Types: single | double | int8 | int16 | int32 | uint8 | uint16 | uint32 | Boolean | fixed point | enumerated | bus

Parameters

Initial condition — Initial output of simulation

0.0 (default) | Scalar | Vector | Matrix | Array | Bus

The **Initial condition** can take a scalar input or use the same data type as the input signal. You cannot run the simulation with NaN or Inf as the **Initial condition**.

Programmatic Use

Block parameter: InitialCondition

Type: character vector

Value: '0' | '[n]' | '[m n]'

Default: '0'

Sample time — Time interval between samples

-1 (default) | Scalar | Vector

The **Sample time** must be a real double scalar that specifies the period or a real double vector of length two that specifies the period and offset. The period and offset must be finite and non-negative with offset less than the period.

Programmatic Use

Block parameter: SampleTime

Type: character vector

Value: '-1' | '[n]' | '[m n]'

Default: '-1'

Extended Capabilities

HDL Code Generation

Generate Verilog and VHDL code for FPGA and ASIC designs using HDL Coder™.

HDL Coder provides additional configuration options that affect HDL implementation and synthesized logic.

HDL Architecture

This block has a single, default HDL architecture.

HDL Block Properties

General	
InputPipeline	Number of input pipeline stages to insert in the generated code. Distributed pipelining and constrained output pipelining can move these registers. The default is 0. For more details, see “InputPipeline”.
OutputPipeline	Number of output pipeline stages to insert in the generated code. Distributed pipelining and constrained output pipelining can move these registers. The default is 0. For more details, see “OutputPipeline”.
ResetType	Suppress reset logic generation. The default is default, which generates reset logic. See also “ResetType”.

Complex Data Support

This block supports code generation for complex signals.

See Also**Blocks**

State Control | Unit Delay | Unit Delay Enabled Resettable Synchronous | Unit Delay Resettable Synchronous

Introduced in R2017b

Unit Delay Resettable Synchronous

Delay input signal by one sample period when external Reset signal is false

Library: HDL Coder / Discrete

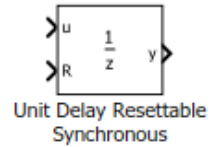

Description

The Unit Delay Resettable Synchronous block delays the input signal u by one sample period when the external Reset signal is false. When the Reset signal is true, the state and output signal take the value of the **Initial condition** parameter. The Reset signal is true when R is not zero and false when R is zero.

The Unit Delay Resettable Synchronous block implementation consists of a Synchronous Subsystem that contains a Resettable Delay block with a **Delay length** of one and a State Control block in Synchronous mode. When you use this block in your model and have HDL Coder installed, your model generates cleaner HDL code and uses fewer hardware resources due to the Synchronous behavior of the State Control block.

Limitations

- The block does not support vector inputs on the Reset port.
- You cannot use the block inside Enabled Subsystem, Triggered Subsystem, or Resettable Subsystem blocks that use Classic semantics. The Subsystem must use Synchronous semantics.

Ports

Input

u – Input signal

Scalar | Vector | Matrix | Array | Bus

The Unit Delay Resettable Synchronous block accepts the input signal of the data types listed below. For more information, see “Data Types Supported by Simulink” (Simulink).

Data Types: single | double | int8 | int16 | int32 | uint8 | uint16 | uint32 | Boolean | fixed point | enumerated | bus

Input

R – Reset signal

Scalar

The Unit Delay Resettable Synchronous block accepts the Reset signal of the data types listed below. For more information, see “Data Types Supported by Simulink” (Simulink).

Data Types: `single` | `double` | `int8` | `int16` | `int32` | `uint8` | `uint16` | `uint32` | `Boolean` | `fixed point`

Output

y — Output signal

Scalar | Vector | Matrix | Array | Bus

Output data type matches input.

Data Types: `single` | `double` | `int8` | `int16` | `int32` | `uint8` | `uint16` | `uint32` | `Boolean` | `fixed point` | `enumerated` | `bus`

Parameters

Initial condition — Initial output of simulation

0.0 (default) | Scalar | Vector | Matrix | Array | Bus

The **Initial condition** can take a scalar input or use the same data type as the input signal. You cannot run the simulation with NaN or Inf as the **Initial condition**.

Programmatic Use

Block parameter: `InitialCondition`

Type: character vector

Value: `'0'` | `'[n]'` | `'[m n]'`

Default: `'0'`

Sample time — Time interval between samples

-1 (default) | Scalar | Vector

The **Sample time** must be a real double scalar that specifies the period or a real double vector of length two that specifies the period and offset. The period and offset must be finite and non-negative with offset less than the period.

Programmatic Use

Block parameter: `SampleTime`

Type: character vector

Value: `'-1'` | `'[n]'` | `'[m n]'`

Default: `'-1'`

Extended Capabilities

HDL Code Generation

Generate Verilog and VHDL code for FPGA and ASIC designs using HDL Coder™.

HDL Coder provides additional configuration options that affect HDL implementation and synthesized logic.

HDL Architecture

This block has a single, default HDL architecture.

HDL Block Properties

General	
InputPipeline	Number of input pipeline stages to insert in the generated code. Distributed pipelining and constrained output pipelining can move these registers. The default is 0. For more details, see "InputPipeline".
OutputPipeline	Number of output pipeline stages to insert in the generated code. Distributed pipelining and constrained output pipelining can move these registers. The default is 0. For more details, see "OutputPipeline".
ResetType	Suppress reset logic generation. The default is default, which generates reset logic. See also "ResetType".

Complex Data Support

This block supports code generation for complex signals.

See Also**Blocks**

State Control | Unit Delay | Unit Delay Enabled Resettable Synchronous | Unit Delay Enabled Synchronous

Introduced in R2017b

Unit Delay Enabled Resettable Synchronous

Delay input signal by one sample period when external Enable signal is true and external Reset signal is false

Library: HDL Coder / Discrete

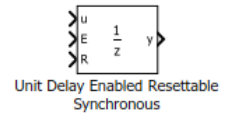

Description

The Unit Delay Enabled Resettable Synchronous block combines the functionality of the Unit Delay Enabled Synchronous block and the Unit Delay Resettable Synchronous block.

The Unit Delay Enabled Resettable Synchronous block delays the input signal u by one sample period when the external Enable signal is true and when the external Reset signal is false. When the Enable signal is false, the state and output signal hold the previous value. When the Reset signal is true, the state and output signal take the value of the **Initial condition** parameter. The Enable and Reset signals are true when E and R are nonzero and false when E and R equal zero.

The Unit Delay Enabled Synchronous block implementation consists of a Synchronous Subsystem that contains an Enabled Delay block with a **Delay length** of one and a State Control block in Synchronous mode. When you use this block in your model and have HDL Coder installed, your model generates cleaner HDL code and uses fewer hardware resources due to the Synchronous behavior of the State Control block.

Limitations

- The block does not support vector inputs on the Reset and Enable ports.
- You cannot use the block inside Enabled Subsystem, Triggered Subsystem, or Resettable Subsystem blocks that use Classic semantics. The Subsystem must use Synchronous semantics.

Ports

Input

u — Input signal

Scalar | Vector | Matrix | Array | Bus

The Unit Delay Enabled Resettable Synchronous block accepts the input signal of the data types listed below. For more information, see “Data Types Supported by Simulink” (Simulink).

Data Types: single | double | int8 | int16 | int32 | uint8 | uint16 | uint32 | Boolean | fixed point | enumerated | bus

Input

E — Enable signal

Scalar

The Unit Delay Enabled Synchronous block accepts the Enable signal of the data types listed below. For more information, see “Data Types Supported by Simulink” (Simulink).

Data Types: `single` | `double` | `int8` | `int16` | `int32` | `uint8` | `uint16` | `uint32` | `Boolean` | `fixed point`

R — Reset signal

Scalar

The Unit Delay Resettable Synchronous block accepts the Reset signal of the data types listed below. For more information, see “Data Types Supported by Simulink” (Simulink).

Data Types: `single` | `double` | `int8` | `int16` | `int32` | `uint8` | `uint16` | `uint32` | `Boolean` | `fixed point`

Output

y — Output signal

Scalar | Vector | Matrix | Array | Bus

Output data type matches input.

Data Types: `single` | `double` | `int8` | `int16` | `int32` | `uint8` | `uint16` | `uint32` | `Boolean` | `fixed point` | `enumerated` | `bus`

Parameters

Initial condition — Initial output of simulation

0.0 (default) | Scalar | Vector | Matrix | Array | Bus

The **Initial condition** can take a scalar input or use the same data type as the input signal. You cannot run the simulation with NaN or Inf as the **Initial condition**.

Programmatic Use

Block parameter: `InitialCondition`

Type: character vector

Value: `'0'` | `'[n]'` | `'[m n]'`

Default: `'0'`

Sample time — Time interval between samples

-1 (default) | Scalar | Vector

The **Sample time** must be a real double scalar that specifies the period or a real double vector of length two that specifies the period and offset. The period and offset must be finite and non-negative with offset less than the period.

Programmatic Use

Block parameter: `SampleTime`

Type: character vector

Value: `'-1'` | `'[n]'` | `'[m n]'`

Default: `'-1'`

Extended Capabilities

HDL Code Generation

Generate Verilog and VHDL code for FPGA and ASIC designs using HDL Coder™.

HDL Coder provides additional configuration options that affect HDL implementation and synthesized logic.

HDL Architecture

This block has a single, default HDL architecture.

HDL Block Properties

General	
InputPipeline	Number of input pipeline stages to insert in the generated code. Distributed pipelining and constrained output pipelining can move these registers. The default is 0. For more details, see “InputPipeline”.
OutputPipeline	Number of output pipeline stages to insert in the generated code. Distributed pipelining and constrained output pipelining can move these registers. The default is 0. For more details, see “OutputPipeline”.
ResetType	Suppress reset logic generation. The default is <code>default</code> , which generates reset logic. See also “ResetType”.

Complex Data Support

This block supports code generation for complex signals.

See Also

State Control | Unit Delay | Unit Delay Resettable Synchronous | Unit Delay Enabled Synchronous

Introduced in R2017b

Properties

ClockHighTime

Specify period, in nanoseconds, during which test bench drives clock input signals high (1)

Settings

ns

Default: 5

The clock high time is expressed as a positive integer.

The `ClockHighTime` and `ClockLowTime` properties define the period and duty cycle for the clock signal. Using the defaults, the clock signal is a square wave (50% duty cycle) with a period of 10 ns.

Usage Notes

HDL Coder ignores this property if `ForceClock` is set to off.

Set or View This Property

To set this property, use `hdlset_param` or `makehdl`. To view the property value, use `hdlget_param`.

See Also

`ClockLowTime`, `ForceClock`, `ForceClockEnable`, `ForceReset`, `HoldTime`

ClockLowTime

Specify period, in nanoseconds, during which test bench drives clock input signals low (0)

Settings

Default: 5

The clock low time is expressed as a positive integer.

The `ClockHighTime` and `ClockLowTime` properties define the period and duty cycle for the clock signal. Using the defaults, the clock signal is a square wave (50% duty cycle) with a period of 10 ns.

Usage Notes

HDL Coder ignores this property if `ForceClock` is set to off.

Set or View This Property

To set this property, use `hdlset_param` or `makehdl`. To view the property value, use `hdlget_param`.

See Also

`ClockHighTime`, `ForceClock`, `ForceClockEnable`, `ForceReset`, `HoldTime`

EDAScriptGeneration

Enable or disable generation of script files for third-party tools

Settings

'on' (default)

Enable generation of script files.

'off'

Disable generation of script files.

Set or View This Property

To set this property, use `hdlset_param` or `makehdl`. To view the property value, use `hdlget_param`.

See Also

“Generate Scripts for Compilation, Simulation, and Synthesis”

ForceClock

Specify whether test bench forces clock input signals

Settings

'on' (default)

Selected (default)

Specify that the test bench forces the clock input signals. When this option is set, the clock high and low time settings control the clock waveform.

'off'

Cleared

Specify that a user-defined external source forces the clock input signals.

Set or View This Property

To set this property, use `hdlset_param` or `makehdl`. To view the property value, use `hdlget_param`.

See Also

`ClockLowTime`, `ClockHighTime`, `ForceClockEnable`, `ForceReset`, `HoldTime`

ForceClockEnable

Specify whether test bench forces clock enable input signals

Settings

'on' (default)

Selected (default)

Specify that the test bench forces the clock enable input signals to active high (1) or active low (0), depending on the setting of the clock enable input value.

'off'

Cleared

Specify that a user-defined external source forces the clock enable input signals.

Set or View This Property

To set this property, use `hdlset_param` or `makehdl`. To view the property value, use `hdlget_param`.

See Also

`ClockHighTime`, `ClockLowTime`, `ForceClock`, `HoldTime`

ForceReset

Specify whether test bench forces reset input signals

Settings

'on' (default)

Selected (default)

Specify that the test bench forces the reset input signals. If you enable this option, you can also specify a hold time to control the timing of a reset.

'off'

Cleared

Specify that a user-defined external source forces the reset input signals.

Set or View This Property

To set this property, use `hdlset_param` or `makehdl`. To view the property value, use `hdlget_param`.

See Also

`ClockHighTime`, `ClockLowTime`, `ForceClock`, `HoldTime`

FPToleranceStrategy

Specify whether to check for floating-point tolerance based on relative error or ULP error

Settings

Use this setting to specify the tolerance strategy for checking the numerical accuracy in the generated test bench. Based on the tolerance strategy that you specify, you can enter a custom tolerance value.

'relative' (default)

When you verify the generated code, HDL Coder checks for the floating-point tolerance based on the relative error.

'ulp'

When you verify the generated code, HDL Coder checks for the floating-point tolerance based on the ULP error.

Set or View This Property

To set this property, use `hdlset_param` or `makehdl`. To view the property value, use `hdlget_param`.

Example

To specify the floating-point tolerance value for a model, use the `hdlset_param` function to specify the tolerance strategy, and then enter the tolerance value. For example, to check the floating-point tolerance based on ULP error and enter the tolerance value:

```
% check for floating-point tolerance based on the ULP error
hdlset_param('sfir_single', 'FPToleranceStrategy', 'ULP');
```

```
% When using ULP error, optionally enter tolerance value greater than or equal to 0
hdlset_param('FP_test_16a', 'FPToleranceValue', 1);
```

See Also

- `FPToleranceValue`
- “Floating point tolerance check based on”
- “Tolerance Value”
- “Getting Started with HDL Coder Native Floating-Point Support”

FPToleranceValue

Enter the tolerance value based on floating-point tolerance check setting

Settings

N

Default: 1e-07

The value of *N* depends on the floating-point tolerance check setting that you specify. Use this setting to specify a custom tolerance value for checking the numerical accuracy in the generated test bench. When you set the **Floating point tolerance check based on** to:

- `relative error`, the default is a tolerance value of 1e-07. When you use this floating-point tolerance check setting, specify the tolerance value as a double data type.
- `ulp error`, the default is a **Tolerance Value** of 0. When you use this floating-point tolerance check setting, specify the tolerance value as an integer. You can specify a **Tolerance Value, N**, that is greater than or equal to 0.

Set or View This Property

To set this property, use `hdlset_param` or `makehdl`. To view the property value, use `hdlget_param`.

Example

To specify the floating-point tolerance value for a model, use the `hdlset_param` function to specify the tolerance strategy, and then enter the tolerance value. For example, to check the floating-point tolerance based on ULP error and enter the tolerance value:

```
% check for floating-point tolerance based on the ULP error
hdlset_param('sfir_single', 'FPToleranceStrategy', 'ULP');
```

```
% When using ULP error, optionally enter tolerance value greater than or equal to 0
hdlset_param('FP_test_16a', 'FPToleranceValue', 1);
```

See Also

- “Tolerance Value”
- `FPToleranceStrategy`
- “Floating point tolerance check based on”

GenerateCoSimBlock

Generate HDL Cosimulation blocks for use in testing DUT

Settings

'on'

If your installation includes one or more of the following HDL simulation features, HDL Coder generates an HDL Cosimulation block for each:

- HDL Verifier for use with Mentor Graphics® ModelSim®
- HDL Verifier for use with Cadence Incisive®

The coder configures the generated HDL Cosimulation blocks to conform to the port and data type interface of the DUT selected for code generation. By connecting an HDL Cosimulation block to your model in place of the DUT, you can cosimulate your design with the desired simulator.

The coder appends the character vector that the `CosimLibPostfix` property specifies to the names of the generated HDL Cosimulation blocks.

'off' (default)

Do not generate HDL Cosimulation blocks.

Set or View This Property

To set this property, use `hdlset_param` or `makehdl`. To view the property value, use `hdlget_param`.

GenerateCoSimModel

Generate model containing HDL Cosimulation block for use in testing DUT

Settings

'ModelSim' (default)

If your installation includes HDL Verifier, the coder generates and opens a Simulink model that contains an HDL Cosimulation block for Mentor Graphics ModelSim.

'Incisive'

If your installation includes HDL Verifier, the coder generates and opens a Simulink model that contains an HDL Cosimulation block for Cadence Incisive.

'None'

Do not create a cosimulation model.

Set or View This Property

To set this property, use `hdlset_param` or `makehdl`. To view the property value, use `hdlget_param`.

See Also

"Generate a Cosimulation Model"

GenerateSVDPI Testbench

Generate SystemVerilog DPI test bench

Settings

'ModelSim' (default)

Generate SystemVerilog DPI test bench, and build-and-run scripts, for the Mentor Graphics ModelSim simulator.

'Incisive'

Generate SystemVerilog DPI test bench, and build-and-run scripts, for the Cadence Incisive simulator.

'VCS' (default)

Generate SystemVerilog DPI test bench, and build-and-run scripts, for the Synopsys® VCS® simulator.

'Vivado'

Generate SystemVerilog DPI test bench, and build-and-run scripts, for the Xilinx Vivado simulator.

When you set this property, the coder generates a direct programming interface (DPI) component for your entire Simulink model, including your DUT and data sources. Your entire model must support C code generation with Simulink Coder. The coder generates a SystemVerilog test bench that compares the output of the DPI component with the output of the HDL implementation of your DUT. The coder also builds shared libraries and generates a simulation script for the simulator you select.

Consider using this option if the default HDL test bench takes a long time to generate or simulate. Generation of a DPI test bench is sometimes faster than the default version because it does not run a full Simulink simulation to create the test bench data. Simulation of a DPI test bench with a large data set is faster than the default version because it does not store the input or expected data in a separate file.

To use this feature, you must have HDL Verifier and Simulink Coder licenses. To run the SystemVerilog testbench with generated VHDL code, you must have a mixed-language simulation license for your HDL simulator.

Limitations This test bench is not supported when you generate HDL code for the top-level Simulink model. Your DUT subsystem must meet the following conditions:

- Input and output data types of the DUT cannot be larger than 64 bits.
 - Input and output ports of the DUT cannot use enumerated data types.
 - Input and output ports cannot be single-precision or double-precision data types.
 - The DUT cannot have multiple clocks. You must set the **Clock inputs** code generation option to **Single**.
 - **Use trigger signal as clock** must not be selected.
 - If the DUT uses vector ports, you must use **Scalarize vector ports** to flatten the interface.
-

Set or View This Property

To set this property, use `hdlset_param` or `makehdl`. To view the property value, use `hdlget_param`.

See Also

“Generate a SystemVerilog DPI Test Bench” on page 2-88.

“Verify HDL Design With Large Data Set Using SystemVerilog DPI Test Bench”

HDLCodeCoverage

Include HDL code coverage switches in generated test bench scripts

Settings

'on'

Generated script includes code coverage switches. When you run the HDL simulation, code coverage is collected for your generated test bench. Specify your HDL simulator in the `SimulationTool` property. The coder generates build-and-run scripts for the simulator you specify.

'off' (default)

Generated script does not include code coverage switches, and does not collect code coverage.

Set or View This Property

To set this property, use `hdlset_param` or `makehdl`. To view the property value, use `hdlget_param`.

See Also

`SimulationTool`

HDLCompileInit

Specify text written to initialization section of compilation script

Settings

'Initialization text'

Default: `'vlib %s\n'`.

Specify text written to initialization section of compilation script as a character vector. If your TargetLanguage is VHDL, the implicit argument, %s, is the contents of the VHDLLibraryName property. If your TargetLanguage is Verilog, the implicit argument is work.

Set or View This Property

To set this property, use `hdlset_param` or `makehdl`. To view the property value, use `hdlget_param`.

See Also

Topics

“Generate Scripts for Compilation, Simulation, and Synthesis”

HDLCompileTerm

Specify text written to termination section of compilation script

Settings

'Termination text'

Specify text written to termination section of compilation script as a character vector. The default is ''.

Set or View This Property

To set this property, use `hdlset_param` or `makehdl`. To view the property value, use `hdlget_param`.

See Also

“Generate Scripts for Compilation, Simulation, and Synthesis”

HDLCompileFilePostfix

Specify postfix appended to file name for generated Mentor Graphics ModelSim compilation scripts

Settings

'Compilation file postfix'

Default: `'_compile.do'`.

Specify the postfix as a character vector. HDL Coder appends the postfix to the file name for generated Mentor Graphics ModelSim compilation scripts.

For example, if the name of the device under test or test bench is `my_design`, HDL Coder adds the postfix `_compile.do` to form the name `my_design_compile.do`.

Set or View This Property

To set this property, use `hdlset_param` or `makehdl`. To view the property value, use `hdlget_param`.

HDLCompileVerilogCmd

Specify command written to compilation script for Verilog files

Settings

'Compilation command'

Default: 'vlog %s %s\n'.

Specify command written to compilation script for Verilog files as a character vector. The two arguments are the contents of the `SimulatorFlags` property and the file name of the current module. To omit the flags, set `SimulatorFlags` to '' (the default).

Set or View This Property

To set this property, use `hdlset_param` or `makehdl`. To view the property value, use `hdlget_param`.

See Also

“Generate Scripts for Compilation, Simulation, and Synthesis”

HDLCompileVHDLCmd

Specify command written to compilation script for VHDL files

Settings

'Compilation command'

Default: 'vcom %s %s\n'.

Specify command written to compilation script for VHDL files as a character vector. The two arguments are the contents of the `SimulatorFlags` property and the file name of the current entity. To omit the flags, set `SimulatorFlags` to '' (the default).

Set or View This Property

To set this property, use `hdlset_param` or `makehdl`. To view the property value, use `hdlget_param`.

See Also

“Generate Scripts for Compilation, Simulation, and Synthesis”

HDLSimCmd

Specify command written to simulation script

Settings

'Simulation command'

Default: `'vsim -novopt %s.%s\n'`.

Specify the command written to simulation script as a character vector. If your `TargetLanguage` is `'VHDL'`, the first implicit argument is the value of `VHDLLibraryName`. If your `TargetLanguage` is `'Verilog'`, the first implicit argument is `'work'`.

The second implicit argument is the top-level module or entity name.

Set or View This Property

To set this property, use `hdlset_param` or `makehdl`. To view the property value, use `hdlget_param`.

See Also

“Generate Scripts for Compilation, Simulation, and Synthesis”

HDLsimInit

Specify text written to initialization section of simulation script

Settings

'Simulation initialization'

Specify text written to initialization section of simulation script as a character vector. The default is

```
['onbreak resume\n',...  
'onerror resume\n']
```

Set or View This Property

To set this property, use `hdlset_param` or `makehdl`. To view the property value, use `hdlget_param`.

See Also

“Generate Scripts for Compilation, Simulation, and Synthesis”

HDLSimFilePostfix

Specify postfix appended to file name for generated Mentor Graphics ModelSim simulation scripts

Settings

'Simulation file postfix'

Default: `_sim.do`.

Specify the postfix as a character vector. HDL Coder appends the postfix to the file name for generated Mentor Graphics ModelSim simulation scripts.

For example, if the name of your test bench file is `my_design`, HDL Coder adds the postfix `_sim.do` to form the name `my_design_tb_sim.do`.

Set or View This Property

To set this property, use `hdlset_param` or `makehdl`. To view the property value, use `hdlget_param`.

HDLsimTerm

Specify text written to termination section of simulation script

Settings

'Termination text'

Specify text written to termination section of simulation script as a character vector. Default is 'run -all\n'.

Set or View This Property

To set this property, use `hdlset_param` or `makehdl`. To view the property value, use `hdlget_param`.

See Also

“Generate Scripts for Compilation, Simulation, and Synthesis”

HDLSimViewWaveCmd

Specify waveform viewing command written to simulation script

Settings

'Waveform view command'

Default: 'add wave sim:%s\n'

Specify waveform viewing command as a character vector. The implicit argument adds the signal paths for the DUT top-level input, output, and output reference signals.

Set or View This Property

To set this property, use `hdlset_param` or `makehdl`. To view the property value, use `hdlget_param`.

See Also

“Generate Scripts for Compilation, Simulation, and Synthesis”

HDLLintCmd

Specify command written to HDL lint script

Settings

'Script command'

Default: ''

Specify the command written to the HDL lint Tcl script as a character vector. The command must contain %s, which is a placeholder for the HDL file name.

Dependencies

If HDLLintCmd is set to the default value, '', and you set HDLLintCmd to one of the supported third-party tools, HDL Coder automatically inserts a tool-specific default command string in the Tcl script.

Usage

If you set HDLLintTool to Custom, you must use %s as a placeholder for the HDL file name in the generated Tcl script. Specify HDLLintCmd using the following format:

```
custom_lint_tool_command -option1 -option2 %s
```

Set or View This Property

To set this property, use hdlset_param or makehdl. To view the property value, use hdlget_param.

See Also

HDLLintTool, HDLLintInit, HDLLintTerm, "Generate an HDL Lint Tool Script"

HDLLintInit

Specify HDL lint script initialization name

Settings

'Initialization name'

Default: ''

Specify the HDL lint script initialization name as a character vector.

Dependencies

If HDLLintInit is set to the default value, '', and you set HDLLintCmd to one of the supported third-party tools, HDL Coder automatically inserts a tool-specific default initialization string in the Tcl script.

Set or View This Property

To set this property, use `hdlset_param` or `makehdl`. To view the property value, use `hdlget_param`.

See Also

HDLLintTool, HDLLintCmd, HDLLintTerm, “Generate an HDL Lint Tool Script”

HDLLintTerm

Specify HDL lint script termination name

Settings

'Script termination name'

Default: ''

Specify the HDL lint script termination name as a character vector.

Dependencies

If HDLLintTerm is set to the default value, '', and you set HDLLintCmd to one of the supported third-party tools, HDL Coder automatically inserts a tool-specific default termination string in the Tcl script.

Set or View This Property

To set this property, use `hdlset_param` or `makehdl`. To view the property value, use `hdlget_param`.

See Also

HDLLintTool, HDLLintCmd, HDLLintInit, "Generate an HDL Lint Tool Script"

HDLLintTool

Select HDL lint tool for which HDL Coder generates scripts

Settings

`'Lint Tool'`

Default: `'None'`.

`HDLLintTool` enables or disables generation of scripts for third-party HDL lint tools. By default, HDL Coder does not generate a lint script.

To generate a script for one of the supported lint tools, set `HDLLintTool` to one of the following:

HDLLintTool Option	Lint Tool
<code>'None'</code>	None. Lint script generation is disabled.
<code>'AscentLint'</code>	Real Intent Ascent Lint
<code>'Leda'</code>	Synopsys Leda
<code>'SpyGlass'</code>	Atrenta SpyGlass
<code>'Custom'</code>	A custom lint tool.

Dependencies

If you set `HDLLintTool` to one of the supported third-party tools, you can generate a Tcl script without setting `HDLLintInit`, `HDLLintCmd`, and `HDLLintTerm` to nondefault values. If the `HDLLintInit`, `HDLLintCmd`, and `HDLLintTerm` have default values, HDL Coder automatically writes tool-specific default initialization, command, and termination strings to the Tcl script.

Set or View This Property

To set this property, use `hdlset_param` or `makehdl`. To view the property value, use `hdlget_param`.

See Also

Properties

[HDLLintCmd](#) | [HDLLintInit](#) | [HDLLintTerm](#)

Topics

[“Generate an HDL Lint Tool Script”](#)

HDLSynthCmd

Specify command written to synthesis script

Settings

'Synthesis command'

Default: none.

Specify command written to synthesis script as a character vector. Your choice of synthesis tool (see HDLSynthTool) sets the synthesis command string. The default is a formatted text string passed to `fprintf` to write the command section of the synthesis script. The implicit argument is the top-level module or entity name. The content of the string is specific to the selected synthesis tool.

Set or View This Property

To set this property, use `hdlset_param` or `makehdl`. To view the property value, use `hdlget_param`.

See Also

HDLSynthTool, HDLSynthInit, HDLSynthTerm, HDLSynthFilePostfix, “Generate Scripts for Compilation, Simulation, and Synthesis”

HDLSynthFilePostfix

Specify postfix appended to file name for generated synthesis scripts

Settings

'file name postfix'

Specify HDLSynthTool as a character vector.

Default: The value of HDLSynthFilePostfix normally defaults to a string that corresponds to the synthesis tool that HDLSynthTool specifies.

For example, if the value of HDLSynthTool is 'Synplify', HDLSynthFilePostfix defaults to '_synplify.tcl'. Then, if the name of the device under test is my_design, HDL Coder adds the postfix _synplify.tcl to form the synthesis script file name my_design_synplify.tcl.

Set or View This Property

To set this property, use hdlset_param or makehdl. To view the property value, use hdlget_param.

See Also

HDLSynthTool, HDLSynthCmd, HDLSynthInit, HDLSynthTerm, “Generate Scripts for Compilation, Simulation, and Synthesis”

HDLSynthInit

Specify text written to initialization section of synthesis script

Settings

'Initialization text'

Default: none

Specify the text written to the synthesis script initialization as a character vector. Your choice of synthesis tool (see HDLSynthTool) sets the synthesis script initialization string. The default is a formatted text passed to `fprintf` to write the initialization section of the synthesis script. The default is a synthesis project creation command. The implicit argument is the top-level module or entity name. The content of the string is specific to the selected synthesis tool.

Set or View This Property

To set this property, use `hdlset_param` or `makehdl`. To view the property value, use `hdlget_param`.

See Also

HDLSynthTool, HDLSynthCmd, HDLSynthTerm, HDLSynthFilePostfix, “Generate Scripts for Compilation, Simulation, and Synthesis”

HDLSynthTerm

Specify text written to termination section of synthesis script

Settings

'Termination text'

Default: none

Specify the synthesis script termination text as a character vector. Your choice of synthesis tool (see HDLSynthTool) sets the synthesis termination string. The default is a formatted text passed to `fprintf` to write the termination and clean up section of the synthesis script. This section does not take arguments. The content of the string is specific to the selected synthesis tool.

Set or View This Property

To set this property, use `hdlset_param` or `makehdl`. To view the property value, use `hdlget_param`.

See Also

HDLSynthTool, HDLSynthCmd, HDLSynthInit, HDLSynthFilePostfix, “Generate Scripts for Compilation, Simulation, and Synthesis”

HDLSynthTool

Select synthesis tool for which HDL Coder generates scripts

Settings

'Synthesis tool'

Default: 'None'.

Specify the synthesis tool as a character vector. HDLSynthTool enables or disables generation of scripts for third-party synthesis tools. By default, HDL Coder does not generate a synthesis script. To generate a script for one of the supported synthesis tools, set HDLSynthTool to one of the following:

Tip The value of HDLSynthTool also sets the postfix (HDLSynthFilePostfix) that the coder appends to generated synthesis script file names.

Choice of HDLSynthTool Value...	Generates Script For...	Sets HDLSynthFilePostfix To...
'None'	N/A; script generation disabled	N/A
'ISE'	Xilinx ISE	'_ise.tcl'
'Libero'	Microsemi Libero	'_libero.tcl'
'Precision'	Mentor Graphics Precision	'_precision.tcl'
'Quartus'	Altera Quartus II	'_quartus.tcl'
'Synplify'	Synopsys Synplify Pro®	'_synplify.tcl'
'Vivado'	Xilinx Vivado	'_vivado.tcl'
'Custom'	A custom synthesis tool	'_custom.tcl'

Set or View This Property

To set this property, use `hdlset_param` or `makehdl`. To view the property value, use `hdlget_param`.

See Also

HDLSynthCmd, HDLSynthInit, HDLSynthTerm, HDLSynthFilePostfix, “Generate Scripts for Compilation, Simulation, and Synthesis”

HoldInputDataBetweenSamples

Specify how long subrate signal values are held in valid state

Settings

'on' (default)

Data values for subrate signals are held in a valid state across N base-rate clock cycles, where N is the number of base-rate clock cycles that elapse per subrate sample period and $N \geq 2$.

'off'

Data values for subrate signals are held in a valid state for only one base-rate clock cycle. For the subsequent base-rate cycles, data is in an unknown state (expressed as 'X') until leading edge of the next subrate sample period.

Usage Notes

In most cases, the default ('on') is the best setting for this property. This setting matches the behavior of a Simulink simulation, in which subrate signals are held valid through each base-rate clock period.

In some cases (for example modeling memory or memory interfaces), it is desirable to set `HoldInputDataBetweenSamples` to 'off'. In this way, you can obtain diagnostic information about when data is in an invalid ('X') state.

Set or View This Property

To set this property, use `hdlset_param` or `makehdl`. To view the property value, use `hdlget_param`.

See Also

`HoldTime`, “Code Generation from Multirate Models”

HoldTime

Specify hold time for input signals and forced reset input signals

Settings

ns

Default: 2

Specify the number of nanoseconds during which the model's data input signals and forced reset input signals are held past the clock rising edge.

The hold time is expressed as a positive integer.

This option applies to reset input signals only if forced resets are enabled.

Usage Notes

The hold time is the amount of time that reset input signals and input data are held past the clock rising edge. The following figures show the application of a hold time (t_{hold}) for reset and data input signals when the signals are forced to active high and active low.

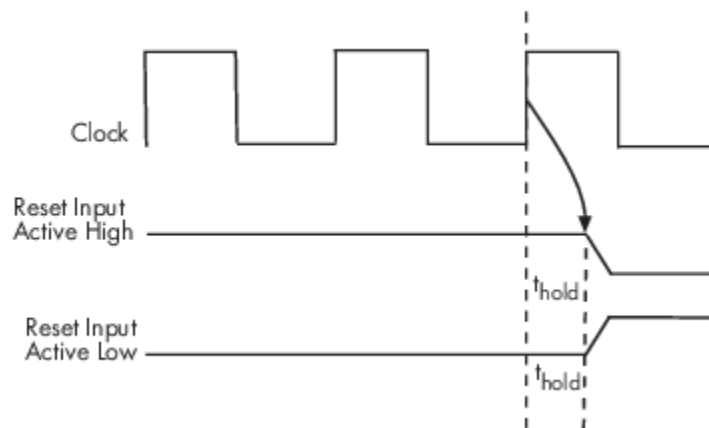

Hold Time for Reset Input Signals

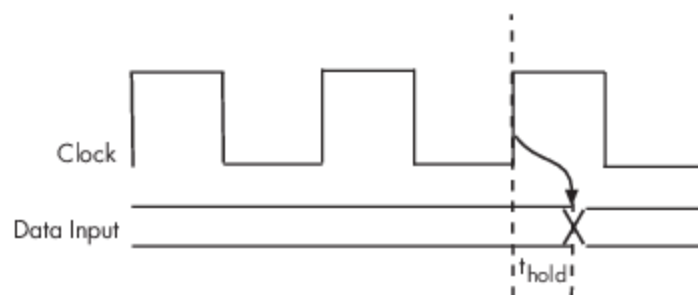

Hold Time for Data Input Signals

Note A reset signal is always asserted for two cycles plus t_{hold} .

Set or View This Property

To set this property, use `hdlset_param` or `makehdl`. To view the property value, use `hdlget_param`.

See Also

`ClockHighTime`, `ClockLowTime`, `ForceClock`

IgnoreDataChecking

Specify number of samples during which output data checking is suppressed

Settings

N

Default: 0.

N must be a positive integer.

When $N > 0$, the test bench suppresses output data checking for the first N output samples after the clock enable output (`ce_out`) is asserted.

Usage Notes

When using pipelined block implementations, output data may be in an invalid state for some number of samples. To avoid spurious test bench errors, determine this number and set `IgnoreDataChecking` accordingly.

Be careful to specify N as a number of samples, not as a number of clock cycles. For a single-rate model, these are equivalent, but they are not equivalent for a multirate model.

You should use `IgnoreDataChecking` in cases where there is a state (register) initial condition in the HDL code that does not match the Simulink state, including the following specific cases:

- When you set the `DistributedPipelining` parameter to 'on' for the MATLAB Function block (see “Distributed Pipeline Insertion for MATLAB Function Blocks”).
- When you set the `ResetType` parameter to 'None' (see “ResetType”) for the following block types:
 - `commcnvintrlv2/Convolutional Deinterleaver`
 - `commcnvintrlv2/Convolutional Interleaver`
 - `commcnvintrlv2/General Multiplexed Deinterleaver`
 - `commcnvintrlv2/General Multiplexed Interleaver`
 - `dpsigops/Delay`
 - `simulink/Additional Math & Discrete/Additional Discrete/Unit Delay Enabled`
 - `simulink/Commonly Used Blocks/Unit Delay`
 - `simulink/Discrete/Delay`
 - `simulink/Discrete/Memory`
 - `simulink/Discrete/Tapped Delay`
 - `simulink/User-Defined Functions/MATLAB Function`
 - `sflib/Chart`
 - `sflib/Truth Table`
- When generating a black box interface to existing manually-written HDL code.

Set or View This Property

To set this property, use `hdlset_param` or `makehdl`. To view the property value, use `hdlget_param`.

InitializeTestBenchInputs

Specify initial value driven on test bench inputs before data is asserted to DUT

Settings

'on'

Initial value driven on test bench inputs is '0'.

'off' (default)

Initial value driven on test bench inputs is 'X' (unknown).

Set or View This Property

To set this property, use `hdlset_param` or `makehdl`. To view the property value, use `hdlget_param`.

MultifileTestBench

Divide generated test bench into helper functions, data, and HDL test bench code files

Description

You can use this property to specify how you want to divide files that contain the test bench code, data, and helper functions.

The file names are derived from the name of the DUT, the **Test bench name postfix** property, and the **Test bench data file name postfix** property as:

DUTname_TestBenchPostfix_TestBenchDataPostfix

For example, if the DUT name is `symmetric_fir`, and the target language is VHDL, the default test bench file names are:

- `symmetric_fir_tb.vhd`: test bench code
- `symmetric_fir_tb_pkg.vhd`: helper functions package
- `symmetric_fir_tb_data.vhd`: data package

If the DUT name is `symmetric_fir` and the target language is Verilog, the default test bench file names are:

- `symmetric_fir_tb.v`: test bench code
- `symmetric_fir_tb_pkg.v`: helper functions package
- `symmetric_fir_tb_data.v`: test bench data

Settings

'on'

Write three separate HDL files. There is a separate file for test bench code, helper functions, and test bench data.

'off' (default)

Write two separate HDL files. One file contains the HDL test bench code. The other file contains the helper functions package and test bench data.

Set or View This Property

To set this property, use `hdlset_param` or `makehdl`. To view the property value, use `hdlget_param`.

See Also

`TestBenchPostFix`, `TestBenchDataPostFix`

SimulationLibPath

Specify the path to the compiled Altera or Xilinx simulation libraries

Settings

'Simulation library path'

Default: ''

Specify the path to the compiled Altera or Xilinx simulation libraries. Altera provides the simulation model files in `\quartus\eda\sim_lib` folder.

Set or View This Property

To set this property, use `hdlset_param` or `makehdl`. To view the property value, use `hdlget_param`.

Usage Example

If you want to set the path to the compiled Xilinx Simulation library, enter:

```
myDUT = gcb;
libpath = '/apps/Xilinx_ISE/XilinxISE-13.4/Linux/ISE_DS/ISE/vhdl/
          mti_se/6.6a/lin64/xilinxcorelib';
hdlset_param (myDUT, 'SimulationLibPath', libpath);
```

See Also

Topics

“Simulation library path”

SimulationTool

Simulator for which the tool generates build-and-run scripts for the test bench and optional code coverage

Settings

'Mentor Graphics ModelSim' | 'Cadence Incisive' | 'Custom'

Default: 'Mentor Graphics ModelSim'

When you select 'Custom', the tool uses the custom script properties.

Set or View This Property

To set this property, use `hdlset_param` or `makehdl`. To view the property value, use `hdlget_param`.

SimulatorFlags

Specify simulator flags to apply to generated compilation scripts

Settings

'compilation simulator flags'

Default: ''

Specify simulator flags to apply to generated compilation scripts as a character vector. The simulator flags are specific to your application and the simulator you are using. For example, if you must use the 1076-1993 VHDL compiler, specify the flag `-93`.

Usage Notes

The flags you specify with this option are added to the compilation command in generated compilation scripts. The simulation command is specified by the `HDLCompileVHDL` or `HDLCompileVerilog` properties.

Set or View This Property

To set this property, use `hdlset_param` or `makehdl`. To view the property value, use `hdlget_param`.

SynthesisProjectAdditionalFiles

Include additional HDL or constraint files in synthesis project

Settings

' ' (default)

Additional project files, such as HDL source files (.v, .vhd) or constraint files (.ucf), that you want to include in your synthesis project, specified as a character vector. Separate file names with a semicolon (;).

You cannot use `SynthesisProjectAdditionalFiles` to include Tcl files. To specify synthesis project Tcl files, use the `AdditionalProjectCreationTclFiles` property of the `hdlcoder.WorkflowConfig` object.

Usage

To include a source file, `src_file.vhd`, and a constraint file, `constraint_file.ucf`, in the synthesis project for a DUT subsystem, `myDUT`:

```
hdlset_param (myDUT, 'SynthesisProjectAdditionalFiles', ...  
              'L:\src_file.vhd;L:\constraint_file.ucf;')
```

Set or View This Property

To set this property, use `hdlset_param` or `makehdl`. To view the property value, use `hdlget_param`.

See Also

`hdlcoder.WorkflowConfig`

TestBenchClockEnableDelay

Define elapsed time in clock cycles between deassertion of reset and assertion of clock enable

Settings

N (integer number of clock cycles)

Default: 1

The `TestBenchClockEnableDelay` property specifies a delay time N , expressed in base-rate clock cycles (the default value is 1) elapsed between the time the reset signal is deasserted and the time the clock enable signal is first asserted. `TestBenchClockEnableDelay` works in conjunction with the `HoldTime` property; after deassertion of reset, the clock enable goes high after a delay of N base-rate clock cycles plus the delay specified by `HoldTime`.

In the figure below, the reset signal (active-high) deasserts after the interval labelled `Hold Time`. The clock enable asserts after a further interval labelled `Clock enable delay`.

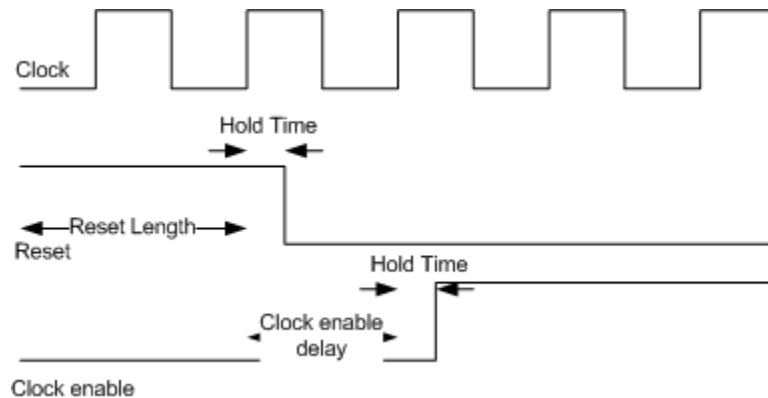

Set or View This Property

To set this property, use `hdlset_param` or `makehdl`. To view the property value, use `hdlget_param`.

See Also

`HoldTime`

TestBenchDataPostFix

Specify suffix added to test bench data file name when generating multifile test bench

Settings

'Data postfix'

Default: `'_data'`.

Specify the postfix as a character vector. HDL Coder applies `TestBenchDataPostFix` only when generating a multi-file test bench (i.e. when `MultifileTestBench` is `'on'`).

For example, if the name of your DUT is `my_test`, and `TestBenchPostFix` has the default value `_tb`, the coder adds the postfix `_data` to form the test bench data file name `my_test_tb_data`.

Set or View This Property

To set this property, use `hdlset_param` or `makehdl`. To view the property value, use `hdlget_param`.

See Also

`MultifileTestBench`, `TestBenchPostFix`

TestBenchPostFix

Specify suffix to test bench name

Settings

'testbench suffix'

Default: `'_tb'`.

Specify the suffix to testbench name as a character vector.

For example, if the name of your DUT is `my_test`, HDL Coder adds the postfix `_tb` to form the name `my_test_tb`.

Set or View This Property

To set this property, use `hdlset_param` or `makehdl`. To view the property value, use `hdlget_param`.

See Also

`MultifileTestBench`, `TestBenchDataPostFix`

TestBenchReferencePostFix

Specify text appended to names of reference signals generated in test bench code

Settings

'Signal name postfix'

Default: '_ref'.

Reference signal data is represented as arrays in the generated test bench code. HDL Coder appends the character vector that TestBenchReferencePostFix specifies to the generated signal names.

Set or View This Property

To set this property, use `hdlset_param` or `makehdl`. To view the property value, use `hdlget_param`.

UseFileIOInTestBench

Specify whether to use data files for reading and writing test bench stimulus and reference data

Settings

'on' (default)

Selected (default)

Create and use data files for reading and writing test bench stimulus and reference data.

'off'

Cleared

Generated test bench contains stimulus and reference data as constants.

Set or View This Property

To set this property, use `hdlset_param` or `makehdl`. To view the property value, use `hdlget_param`.

Classes for HDL Code Generation from Simulink

hdlcoder.FloatingPointTargetConfig class

Package: hdlcoder

Specify floating-point target configuration for floating-point library

Description

The `hdlcoder.FloatingPointTargetConfig` object sets options for HDL Coder to generate synthesizable floating-point code. To create an `hdlcoder.FloatingPointTargetConfig` object for a floating-point library, use the `hdlcoder.createFloatingPointTargetConfig` function. You can create a floating-point configuration object for these floating-point libraries:

- Native Floating Point
- Altera Megafunctions (ALTERA FP Functions)
- Altera Megafunctions (ALTFP)
- Xilinx LogiCORE®

Construction

`fpconfig = hdlcoder.createFloatingPointConfig(library)` creates an `hdlcoder.FloatingPointTargetConfig` object for a floating-point library.

`fpconfig = hdlcoder.createFloatingPointConfig(library,Name,Value)` creates an `hdlcoder.FloatingPointTargetConfig` object with additional options specified by one or more `Name,Value` pair arguments. `Name` can also be a property name on page 5-2 and `Value` is the corresponding value. `Name` must appear inside single quotes (' '). You can specify several name-value pair arguments in any order as `Name1,Value1,...,NameN,ValueN`.

The name-value pair arguments that you can specify depend on the library that you select for creating the floating-point configuration.

Input Arguments

Library — Floating point library name

None (default) | NATIVEFLOATINGPOINT | ALTERAFPFUNCTIONS | ALTFP | XILINXLOGICORE

Floating-point library name, specified as a character vector

Example: 'ALTERAFPFUNCTIONS'

Properties

Native Floating Point

HandleDenormals — Specify whether to handle denormal numbers in your design

'off' (default) | 'on'

Specify whether you want HDL Coder to handle denormal numbers in your design. Specify this property as a character vector. Denormal numbers are nonzero numbers that are smaller than the smallest normal number.

LatencyStrategy — Specify whether to use maximum or minimum latency for the native floating-point operator`'MAX'` (default) | `'MIN'` | `'ZERO'`

Specify whether you want HDL Coder to use maximum or minimum latency setting for the floating-point operators that your design uses. Specify this property as a character vector.

MantissaMultiplyStrategy — Specify how you want HDL Coder to implement the mantissa multiplication operation when your design uses floating-point multipliers`'FullMultiplier'` (default) | `'PartMultiplierPartAddShift'` | `'NoMultiplierFullAddShift'`

Specify how you want HDL Coder to implement the mantissa multiplication process for floating-point multipliers in your design. With this option, you can control the DSP usage on the target platform for your design. To learn more, see “Mantissa Multiplier Strategy”.

Altera FP Functions**InitializeIPipelinesToZero — Specify whether to initialize pipeline registers in the Altera Megafunction IP to zero**`true` (default) | `false`

Specify whether you want HDL Coder to initialize pipeline registers in the Altera Megafunction IP to zero. Specify this property as a logical. To avoid potential numerical mismatches in the HDL simulation, leave `InitializeIPipelinesToZero` set to `true`.

ALTFP and Xilinx LogiCORE**LatencyStrategy — Specify whether to use maximum or minimum latency when mapping your design to FPGA floating-point target libraries**`'MIN'` (default) | `'MAX'`

Specify whether you want the design to map to minimum or maximum latency with Xilinx LogiCORE or Altera Megafunction IP. Specify this property as a character vector.

Objective — Specify whether to optimize the design for speed or area when mapping your design to FPGA floating-point target libraries`'SPEED'` (default) | `'AREA'`

Specify whether you want the design to map to minimum or maximum latency with Xilinx LogiCORE or Altera Megafunction IP. Specify this property as a character vector.

Methods`createFloatingPointTargetConfig`

Create floating-point target configuration for floating-point library that you specify

Examples

Create Floating-Point Configuration with Native Floating Point and Generate Code

This example shows how to create a floating-point target configuration with the native floating-point support in HDL Coder, and then generate code.

Create a Floating-Point Target Configuration

To create a floating-point configuration, use `hdlcoder.createFloatingPointTargetConfig`.

```
load_system('sfir_single');
fpconfig = hdlcoder.createFloatingPointTargetConfig('NATIVEFLOATINGPOINT')
```

```
fpconfig =
```

```
FloatingPointTargetConfig with properties:
```

```
Library: 'NativeFloatingPoint'
LibrarySettings: [1x1 fpconfig.NFPLatencyDrivenMode]
IPConfig: [1x1 hdlcoder.FloatingPointTargetConfig.IPConfig]
```

Specify Custom Library Settings

Optionally, to customize the floating-point configuration, specify custom library settings.

```
fpconfig.LibrarySettings.HandleDenormals = 'off';
fpconfig.LibrarySettings.LatencyStrategy = 'MIN';
fpconfig.LibrarySettings.MantissaMultiplyStrategy = 'NoMultiplierFullAddShift';
fpconfig.LibrarySettings
```

```
ans =
```

```
NFPLatencyDrivenMode with properties:
```

```
LatencyStrategy: 'MIN'
HandleDenormals: 'off'
MantissaMultiplyStrategy: 'NoMultiplierFullAddShift'
Version: '1.0.0'
```

View Latency of Native Floating Point Operators

The `IPConfig` object displays the maximum and minimum latency values of the floating-point operators.

```
fpconfig.IPConfig
```

```
ans =
```

Name	Data Type	MaxLatency	MinLatency
'ABS'	'SINGLE'	0	0
'ADDSUB'	'SINGLE'	12	7
'ATAN'	'SINGLE'	36	36
'ATAN2'	'SINGLE'	42	42

'CONVERT'	'NUMERICTYPE_TO_SINGLE'	6	6
'CONVERT'	'SINGLE_TO_NUMERICTYPE'	6	6
'COS'	'SINGLE'	27	27
'DIV'	'SINGLE'	32	32
'EXP'	'SINGLE'	23	23
'FIX'	'SINGLE'	3	3
'LOG'	'SINGLE'	20	20
'MINMAX'	'SINGLE'	3	3
'MOD'	'SINGLE'	0	0
'MUL'	'SINGLE'	8	8
'POW2'	'SINGLE'	2	2
'RECIP'	'SINGLE'	19	19
'RELOP'	'SINGLE'	3	3
'REM'	'SINGLE'	0	0
'ROUNDING'	'SINGLE'	5	5
'RSQRT'	'SINGLE'	17	17
'SIGNUM'	'SINGLE'	0	0
'SIN'	'SINGLE'	27	27
'SINCOS'	'SINGLE'	27	27
'SQRT'	'SINGLE'	28	28
'UMINUS'	'SINGLE'	0	0

Generate Code

```
makehdl('sfir_single/symmetric_fir','FloatingPointTargetConfiguration',fpconfig, ...
        'TargetDirectory','C:/NativeFloatingPoint/hdlsrc')
```

```
### Generating HDL for 'sfir_single/symmetric_fir'.
### Starting HDL check.
### The code generation and optimization options you have chosen have introduced additional pipe
### The delay balancing feature has automatically inserted matching delays for compensation.
### The DUT requires an initial pipeline setup latency. Each output port experiences these addit
### Output port 0: 30 cycles.
### Output port 1: 30 cycles.
### Begin VHDL Code Generation for 'sfir_single'.
### Working on sfir_single/symmetric_fir/nfp_add_comp as C:\NativeFloatingPoint\hdlsrc\sfir_sing
### Working on sfir_single/symmetric_fir/nfp_mul_comp as C:\NativeFloatingPoint\hdlsrc\sfir_sing
### Working on sfir_single/symmetric_fir as C:\NativeFloatingPoint\hdlsrc\sfir_single\symmetric_
### Generating package file C:\NativeFloatingPoint\hdlsrc\sfir_single\symmetric_fir_pkg.vhd.
### Creating HDL Code Generation Check Report file://C:\NativeFloatingPoint\hdlsrc\sfir_single\sy
### HDL check for 'sfir_single' complete with 0 errors, 0 warnings, and 0 messages.
### HDL code generation complete.
```

The generated VHDL code is saved in the `hdlsrc` folder.

See Also

[customize | hdlcoder.FloatingPointTargetConfig.IPConfig](#)

Topics

- “FPGA Floating-Point Library IP Mapping”
- “Single Precision Floating Point Support: Field-Oriented Control Algorithm”
- “Share Floating-Point IPs”
- “Generate HDL Code for FPGA Floating-Point Target Libraries”
- “Customize Floating-Point IP Configuration”
- “Generate Target-Independent HDL Code with Native Floating-Point”

Introduced in R2016b

createFloatingPointTargetConfig

Class: `hdlcoder.FloatingPointTargetConfig`

Package: `hdlcoder`

Create floating-point target configuration for floating-point library that you specify

Syntax

```
fpconfig = hdlcoder.createFloatingPointConfig(library)
fpconfig = hdlcoder.createFloatingPointConfig(library,Name,Value)
```

Description

To create a floating-point target configuration object for a floating-point library, use the `hdlcoder.createFloatingPointTargetConfig` function. You can create a floating-point configuration object for these libraries:

- Native Floating Point
- Altera Megafunctions (ALTERA FP Functions)
- Altera Megafunctions (ALTFP)
- Xilinx LogiCORE

`fpconfig = hdlcoder.createFloatingPointConfig(library)` creates an `hdlcoder.FloatingPointTargetConfig` object for a given floating-point library.

`fpconfig = hdlcoder.createFloatingPointConfig(library,Name,Value)` creates an `hdlcoder.FloatingPointTargetConfig` object with additional options specified by one or more `Name,Value` pair arguments. `Name` can also be a property name and `Value` is the corresponding value. `Name` must appear inside single quotes (' '). You can specify several name-value pair arguments in any order as `Name1,Value1,...,NameN,ValueN`.

Input Arguments

Library — Floating point library name

None (default) | NATIVEFLOATINGPOINT | ALTERAFPFUNCTIONS | ALTFP | XILINXLOGICORE

Floating-point library name, specified as a character vector

Example: 'ALTERAFPFUNCTIONS'

Name-Value Pair Arguments

Specify optional comma-separated pairs of `Name,Value` arguments. `Name` is the argument name and `Value` is the corresponding value. `Name` must appear inside quotes. You can specify several name and value pair arguments in any order as `Name1,Value1,...,NameN,ValueN`.

The name-value pair arguments that you can specify depend on the library that you select for creating the floating-point configuration.

Native Floating Point

HandleDenormals — Specify whether to handle denormal numbers in your design

'off' (default) | 'on'

Specify whether you want HDL Coder to handle denormal numbers in your design. Specify this property as a character vector. Denormal numbers are nonzero numbers that are smaller than the smallest normal number. To specify this property, for `Library`, select `NATIVEFLOATINGPOINT`.

LatencyStrategy — Specify whether to use maximum or minimum latency for the native floating-point operator

'MAX' (default) | 'MIN' | 'ZERO'

Specify whether you want HDL Coder to use maximum or minimum latency setting for the floating-point operators that your design uses. Specify this property as a character vector. To specify this property, for `Library`, select `NATIVEFLOATINGPOINT`.

MantissaMultiplyStrategy — Specify how you want HDL Coder to implement the mantissa multiplication operation when your design uses floating-point multipliers

'FullMultiplier' (default) | 'PartMultiplierPartAddShift' |
'NoMultiplierFullAddShift'

Specify how you want HDL Coder to implement the mantissa multiplication process for floating-point multipliers in your design. With this option, you can control the DSP usage on the target platform for your design. To learn more, see “Mantissa Multiplier Strategy”.

Altera FP Functions

InitializeIPipelinesToZero — Specify whether to initialize pipeline registers in the Altera Megafunction IP to zero

true (default) | false

Specify whether you want HDL Coder to initialize pipeline registers in the Altera Megafunction IP to zero. Specify this property as a logical. To avoid potential numerical mismatches in the HDL simulation, leave `InitializeIPipelinesToZero` set to `true`. To specify this property, for `Library`, select `ALTERAFPFUNCTIONS`.

ALTFP and Xilinx LogiCORE

LatencyStrategy — Specify whether to use maximum or minimum latency when mapping your design to FPGA floating-point target libraries

'MIN' (default) | 'MAX'

Specify whether you want the design to map to minimum or maximum latency with Xilinx LogiCORE or Altera Megafunction IP. Specify this property as a character vector.

Objective — Specify whether to optimize the design for speed or area when mapping your design to FPGA floating-point target libraries

'SPEED' (default) | 'AREA'

Specify whether you want the design to map to minimum or maximum latency with Xilinx LogiCORE or Altera Megafunction IP. Specify this property as a character vector.

Examples

Create Floating-Point Configuration with Native Floating Point and Generate Code

This example shows how to create a floating-point target configuration with the native floating-point support in HDL Coder, and then generate code.

Create a Floating-Point Target Configuration

To create a floating-point configuration, use `hdlcoder.createFloatingPointTargetConfig`.

```
load_system('sfir_single');
fpconfig = hdlcoder.createFloatingPointTargetConfig('NATIVEFLOATINGPOINT')
```

```
fpconfig =
```

```
FloatingPointTargetConfig with properties:
```

```
Library: 'NativeFloatingPoint'
LibrarySettings: [1x1 fpconfig.NFPLatencyDrivenMode]
IPConfig: [1x1 hdlcoder.FloatingPointTargetConfig.IPConfig]
```

Specify Custom Library Settings

Optionally, to customize the floating-point configuration, specify custom library settings.

```
fpconfig.LibrarySettings.HandleDenormals = 'off';
fpconfig.LibrarySettings.LatencyStrategy = 'MIN';
fpconfig.LibrarySettings.MantissaMultiplyStrategy = 'NoMultiplierFullAddShift';
fpconfig.LibrarySettings
```

```
ans =
```

```
NFPLatencyDrivenMode with properties:
```

```
LatencyStrategy: 'MIN'
HandleDenormals: 'off'
MantissaMultiplyStrategy: 'NoMultiplierFullAddShift'
Version: '1.0.0'
```

View Latency of Native Floating Point Operators

The `IPConfig` object displays the maximum and minimum latency values of the floating-point operators.

```
fpconfig.IPConfig
```

```
ans =
```

Name	Data Type	Max Latency	Min Latency
'ABS'	'SINGLE'	0	0
'ADDSUB'	'SINGLE'	12	7
'ATAN'	'SINGLE'	36	36
'ATAN2'	'SINGLE'	42	42

'CONVERT'	'NUMERICTYPE_TO_SINGLE'	6	6
'CONVERT'	'SINGLE_TO_NUMERICTYPE'	6	6
'COS'	'SINGLE'	27	27
'DIV'	'SINGLE'	32	32
'EXP'	'SINGLE'	23	23
'FIX'	'SINGLE'	3	3
'LOG'	'SINGLE'	20	20
'MINMAX'	'SINGLE'	3	3
'MOD'	'SINGLE'	0	0
'MUL'	'SINGLE'	8	8
'POW2'	'SINGLE'	2	2
'RECIP'	'SINGLE'	19	19
'RELOP'	'SINGLE'	3	3
'REM'	'SINGLE'	0	0
'ROUNDING'	'SINGLE'	5	5
'RSQRT'	'SINGLE'	17	17
'SIGNUM'	'SINGLE'	0	0
'SIN'	'SINGLE'	27	27
'SINCOS'	'SINGLE'	27	27
'SQRT'	'SINGLE'	28	28
'UMINUS'	'SINGLE'	0	0

Generate Code

```
makehdl('sfir_single/symmetric_fir','FloatingPointTargetConfiguration',fpconfig, ...
        'TargetDirectory','C:/NativeFloatingPoint/hdlsrc')
```

```
### Generating HDL for 'sfir_single/symmetric_fir'.
### Starting HDL check.
### The code generation and optimization options you have chosen have introduced additional pipe
### The delay balancing feature has automatically inserted matching delays for compensation.
### The DUT requires an initial pipeline setup latency. Each output port experiences these addit
### Output port 0: 30 cycles.
### Output port 1: 30 cycles.
### Begin VHDL Code Generation for 'sfir_single'.
### Working on sfir_single/symmetric_fir/nfp_add_comp as C:\NativeFloatingPoint\hdlsrc\sfir_sing
### Working on sfir_single/symmetric_fir/nfp_mul_comp as C:\NativeFloatingPoint\hdlsrc\sfir_sing
### Working on sfir_single/symmetric_fir as C:\NativeFloatingPoint\hdlsrc\sfir_single\symmetric_
### Generating package file C:\NativeFloatingPoint\hdlsrc\sfir_single\symmetric_fir_pkg.vhd.
### Creating HDL Code Generation Check Report file://C:\NativeFloatingPoint\hdlsrc\sfir_single\sy
### HDL check for 'sfir_single' complete with 0 errors, 0 warnings, and 0 messages.
### HDL code generation complete.
```

The generated VHDL code is saved in the `hdlsrc` folder.

See Also

`customize | hdlcoder.FloatingPointTargetConfig.IPConfig`

Topics

- “FPGA Floating-Point Library IP Mapping”
- “Single Precision Floating Point Support: Field-Oriented Control Algorithm”
- “Share Floating-Point IPs”
- “Generate HDL Code for FPGA Floating-Point Target Libraries”
- “Customize Floating-Point IP Configuration”
- “Generate Target-Independent HDL Code with Native Floating-Point”

hdlcoder.FloatingPointTargetConfig.IPConfig class

Package: hdlcoder

Specify IP settings for selected floating-point configuration

Description

Use the `hdlcoder.FloatingPointTargetConfig.IPConfig` object to see the list of supported IP blocks for a floating-point library. The IP configuration depends on the library settings. The library settings are specific to the floating-point library that you choose.

- 1 Create a floating-point target configuration object for the library.

```
fpconfig = hdlcoder.createFloatingPointTargetConfig('ALTFP');
```

- 2 To see the IP settings, use the `IPConfig` object.

```
fpconfig.IPConfig
```

Optionally, to customize the IP configuration, use the `customize` method of the floating-point configuration object.

Construction

`fpconfig.IPConfig` shows the IP settings for the `fpconfig` floating-point target configuration that you create for the floating-point library.

Methods

`customize` Customize IP configuration for specified floating-point library

Examples

Create and Customize Floating Point Configuration and Generate Code

This example shows how to create a floating-point target configuration with Altera® Megafunctions (ALTFP) in HDL Coder, and then generate code.

Create a Floating-Point Target Configuration

To create a floating-point configuration, use `hdlcoder.createFloatingPointTargetConfig`. Before creating a configuration, set up the path to your synthesis tool.

```
hdlsetuptoolpath('ToolName', 'Altera Quartus II', ...
    'ToolPath', 'C:/Altera/16.0/quartus/bin64/quartus.exe');
load_system('sfir_single')
fpconfig = hdlcoder.createFloatingPointTargetConfig('ALTFP')
```

Prepending following Altera Quartus II path(s) to the system path:
C:\Altera\16.0\quartus\bin64

```
fpconfig =
    FloatingPointTargetConfig with properties:
        Library: 'ALTFP'
        LibrarySettings: [1x1 fpconfig.LatencyDrivenMode]
        IPConfig: [1x1 hdlcoder.FloatingPointTargetConfig.IPConfig]
```

Specify Custom Library Settings

Optionally, to customize the floating-point configuration, specify custom library settings.

```
fpconfig.LibrarySettings.LatencyStrategy = 'MAX';
fpconfig.LibrarySettings.Objective = 'AREA';
fpconfig.LibrarySettings
```

```
ans =
    LatencyDrivenMode with properties:
        LatencyStrategy: 'MAX'
        Objective: 'AREA'
```

View Latency of Floating-Point IPs

The IPConfig object displays the maximum and minimum latency values of the floating-point operators.

```
fpconfig.IPConfig
```

```
ans =
```

Name	DataType	MinLatency	MaxLatency	Latency	ExtraArgs
'ABS'	'DOUBLE'	1	1	-1	''
'ABS'	'SINGLE'	1	1	-1	''
'ADDSUB'	'DOUBLE'	7	14	-1	''
'ADDSUB'	'SINGLE'	7	14	-1	''
'CONVERT'	'DOUBLE_TO_NUMERICTYPE'	6	6	-1	''
'CONVERT'	'NUMERICTYPE_TO_DOUBLE'	6	6	-1	''
'CONVERT'	'NUMERICTYPE_TO_SINGLE'	6	6	-1	''
'CONVERT'	'SINGLE_TO_NUMERICTYPE'	6	6	-1	''
'COS'	'SINGLE'	35	35	-1	''
'DIV'	'DOUBLE'	10	61	-1	''
'DIV'	'SINGLE'	6	33	-1	''
'EXP'	'DOUBLE'	25	25	-1	''
'EXP'	'SINGLE'	17	17	-1	''
'LOG'	'DOUBLE'	34	34	-1	''
'LOG'	'SINGLE'	21	21	-1	''
'MUL'	'DOUBLE'	11	11	-1	''
'MUL'	'SINGLE'	11	11	-1	''
'RECIP'	'DOUBLE'	27	27	-1	''
'RECIP'	'SINGLE'	20	20	-1	''

'RELOP'	'DOUBLE'	1	3	-1	''
'RELOP'	'SINGLE'	1	3	-1	''
'RSQRT'	'DOUBLE'	36	36	-1	''
'RSQRT'	'SINGLE'	26	26	-1	''
'SIN'	'SINGLE'	36	36	-1	''
'SQRT'	'DOUBLE'	30	57	-1	''
'SQRT'	'SINGLE'	16	28	-1	''

Customize Latency of ADDSUB IP

Using the customize method of the IPConfig object, you can customize the latency of the floating-point IP and specify any additional arguments.

```
fpconfig.IPConfig.customize('ADDSUB', 'Single', 'Latency', 6);
fpconfig.IPConfig
```

ans =

Name	DataType	MinLatency	MaxLatency	Latency	ExtraArgs
'ABS'	'DOUBLE'	1	1	-1	''
'ABS'	'SINGLE'	1	1	-1	''
'ADDSUB'	'DOUBLE'	7	14	-1	''
'ADDSUB'	'SINGLE'	7	14	6	''
'CONVERT'	'DOUBLE_TO_NUMERICTYPE'	6	6	-1	''
'CONVERT'	'NUMERICTYPE_TO_DOUBLE'	6	6	-1	''
'CONVERT'	'NUMERICTYPE_TO_SINGLE'	6	6	-1	''
'CONVERT'	'SINGLE_TO_NUMERICTYPE'	6	6	-1	''
'COS'	'SINGLE'	35	35	-1	''
'DIV'	'DOUBLE'	10	61	-1	''
'DIV'	'SINGLE'	6	33	-1	''
'EXP'	'DOUBLE'	25	25	-1	''
'EXP'	'SINGLE'	17	17	-1	''
'LOG'	'DOUBLE'	34	34	-1	''
'LOG'	'SINGLE'	21	21	-1	''
'MUL'	'DOUBLE'	11	11	-1	''
'MUL'	'SINGLE'	11	11	-1	''
'RECIP'	'DOUBLE'	27	27	-1	''
'RECIP'	'SINGLE'	20	20	-1	''
'RELOP'	'DOUBLE'	1	3	-1	''
'RELOP'	'SINGLE'	1	3	-1	''
'RSQRT'	'DOUBLE'	36	36	-1	''
'RSQRT'	'SINGLE'	26	26	-1	''
'SIN'	'SINGLE'	36	36	-1	''
'SQRT'	'DOUBLE'	30	57	-1	''
'SQRT'	'SINGLE'	16	28	-1	''

Generate Code

```
makehdl('sfir_single/symmetric_fir', 'FloatingPointTargetConfiguration', fpconfig, ...
        'TargetDirectory', 'C:/FloatingPoint/hd/src', 'SynthesisToolChipFamily', 'Arria10')

### Generating HDL for 'sfir_single/symmetric_fir'.
### Starting HDL check.
### Using C:\Altera\16.0\quartus\bin64\qmegawiz for the selected floating point IP library.
```

```
### The code generation and optimization options you have chosen have introduced additional pipe
### The delay balancing feature has automatically inserted matching delays for compensation.
### The DUT requires an initial pipeline setup latency. Each output port experiences these addit
### Output port 0: 30 cycles.
### Output port 1: 30 cycles.
### Generating Altera(R) megafunction: altfp_add_single for latency of 6.
### Found an existing generated file in a previous session: (C:\FloatingPoint\hdlsrc\sfir_single
### Done.
### Generating Altera(R) megafunction: altfp_mul_single for latency of 11.
### Found an existing generated file in a previous session: (C:\FloatingPoint\hdlsrc\sfir_single
### Done.
### Begin VHDL Code Generation for 'sfir_single'.
### Working on sfir_single/symmetric_fir as C:\FloatingPoint\hdlsrc\sfir_single\symmetric_fir.vh
### Generating package file C:\FloatingPoint\hdlsrc\sfir_single\symmetric_fir_pkg.vhd.
### Creating HDL Code Generation Check Report file://C:\FloatingPoint\hdlsrc\sfir_single\symmetr
### HDL check for 'sfir_single' complete with 0 errors, 7 warnings, and 0 messages.
### HDL code generation complete.
```

The latency of the ADDSUB IP is 6 and not the maximum latency value of 14.

The generated VHDL code is saved in the `hdlsrc` folder.

See Also

`hdlcoder.FloatingPointTargetConfig`

Topics

“FPGA Floating-Point Library IP Mapping”

“Single Precision Floating Point Support: Field-Oriented Control Algorithm”

“Share Floating-Point IPs”

“Generate HDL Code for FPGA Floating-Point Target Libraries”

“Customize Floating-Point IP Configuration”

“Generate Target-Independent HDL Code with Native Floating-Point”

Introduced in R2016b

customize

Class: `hdlcoder.FloatingPointTargetConfig.IPConfig`

Package: `hdlcoder`

Customize IP configuration for specified floating-point library

Syntax

```
fpconfig.IPConfig.customize(Name,DataType,Name,Value)
```

Description

`fpconfig.IPConfig.customize(Name,DataType,Name,Value)` customizes the `fpconfig` floating-point configuration with additional options specified by one or more `Name,Value` pair arguments.

Input Arguments

Name — Name of the floating-point IP

' ' (default) | character vector

Name of the floating-point IP to customize, specified as a character vector.

Example: 'ADDSUB'

DataType — Data type of the floating-point IP

' ' (default) | character vector

Data type of the floating-point IP to customize, specified as a character vector.

Example: 'SINGLE'

Name-Value Pair Arguments

Specify optional comma-separated pairs of `Name,Value` arguments. `Name` is the argument name and `Value` is the corresponding value. `Name` must appear inside quotes. You can specify several name and value pair arguments in any order as `Name1,Value1,...,NameN,ValueN`.

Latency — Latency of the floating-point IP

-1 (default) | positive integer

Specify a custom latency value for the floating-point IP as an integer.

Example: `fpconfig.IPConfig.customize('ADDSUB','Double','Latency',6)` specifies a custom latency value of 6 for the ADDSUB IP.

ExtraArgs — Specify any additional arguments of the floating-point IP

' ' (default) | character vector

Specify any additional arguments of the floating-point IP as a character vector.

Example:

```
fpconfig.IPConfig.customize('ADDSUB', 'Double', 'Latency', 6, 'ExtraArgs', 'CSET  
c_mult_usage=Full_Usage') specifies that you want to use DSP blocks on the target device.
```

Examples

Create and Customize Floating Point Configuration and Generate Code

This example shows how to create a floating-point target configuration with Altera® Megafunctions (ALTFP) in HDL Coder, and then generate code.

Create a Floating-Point Target Configuration

To create a floating-point configuration, use `hdlcoder.createFloatingPointTargetConfig`. Before creating a configuration, set up the path to your synthesis tool.

```
hdlsetuptoolpath('ToolName', 'Altera Quartus II', ...  
    'ToolPath', 'C:/Altera/16.0/quartus/bin64/quartus.exe');  
load_system('sfir_single')  
fpconfig = hdlcoder.createFloatingPointTargetConfig('ALTFP')
```

Prepending following Altera Quartus II path(s) to the system path:
C:\Altera\16.0\quartus\bin64

```
fpconfig =
```

```
    FloatingPointTargetConfig with properties:
```

```
        Library: 'ALTFP'  
    LibrarySettings: [1x1 fpconfig.LatencyDrivenMode]  
        IPConfig: [1x1 hdlcoder.FloatingPointTargetConfig.IPConfig]
```

Specify Custom Library Settings

Optionally, to customize the floating-point configuration, specify custom library settings.

```
fpconfig.LibrarySettings.LatencyStrategy = 'MAX';  
fpconfig.LibrarySettings.Objective = 'AREA';  
fpconfig.LibrarySettings
```

```
ans =
```

```
    LatencyDrivenMode with properties:
```

```
        LatencyStrategy: 'MAX'  
        Objective: 'AREA'
```

View Latency of Floating-Point IPs

The `IPConfig` object displays the maximum and minimum latency values of the floating-point operators.

```
fpconfig.IPConfig
```

ans =

Name	DataType	MinLatency	MaxLatency	Latency	ExtraArgs
'ABS'	'DOUBLE'	1	1	-1	''
'ABS'	'SINGLE'	1	1	-1	''
'ADDSUB'	'DOUBLE'	7	14	-1	''
'ADDSUB'	'SINGLE'	7	14	-1	''
'CONVERT'	'DOUBLE_TO_NUMERICTYPE'	6	6	-1	''
'CONVERT'	'NUMERICTYPE_TO_DOUBLE'	6	6	-1	''
'CONVERT'	'NUMERICTYPE_TO_SINGLE'	6	6	-1	''
'CONVERT'	'SINGLE_TO_NUMERICTYPE'	6	6	-1	''
'COS'	'SINGLE'	35	35	-1	''
'DIV'	'DOUBLE'	10	61	-1	''
'DIV'	'SINGLE'	6	33	-1	''
'EXP'	'DOUBLE'	25	25	-1	''
'EXP'	'SINGLE'	17	17	-1	''
'LOG'	'DOUBLE'	34	34	-1	''
'LOG'	'SINGLE'	21	21	-1	''
'MUL'	'DOUBLE'	11	11	-1	''
'MUL'	'SINGLE'	11	11	-1	''
'RECIP'	'DOUBLE'	27	27	-1	''
'RECIP'	'SINGLE'	20	20	-1	''
'RELOP'	'DOUBLE'	1	3	-1	''
'RELOP'	'SINGLE'	1	3	-1	''
'RSQRT'	'DOUBLE'	36	36	-1	''
'RSQRT'	'SINGLE'	26	26	-1	''
'SIN'	'SINGLE'	36	36	-1	''
'SQRT'	'DOUBLE'	30	57	-1	''
'SQRT'	'SINGLE'	16	28	-1	''

Customize Latency of ADDSUB IP

Using the customize method of the IPConfig object, you can customize the latency of the floating-point IP and specify any additional arguments.

```
fpconfig.IPConfig.customize('ADDSUB','Single','Latency',6);
fpconfig.IPConfig
```

ans =

Name	DataType	MinLatency	MaxLatency	Latency	ExtraArgs
'ABS'	'DOUBLE'	1	1	-1	''
'ABS'	'SINGLE'	1	1	-1	''
'ADDSUB'	'DOUBLE'	7	14	-1	''
'ADDSUB'	'SINGLE'	7	14	6	''
'CONVERT'	'DOUBLE_TO_NUMERICTYPE'	6	6	-1	''
'CONVERT'	'NUMERICTYPE_TO_DOUBLE'	6	6	-1	''
'CONVERT'	'NUMERICTYPE_TO_SINGLE'	6	6	-1	''
'CONVERT'	'SINGLE_TO_NUMERICTYPE'	6	6	-1	''
'COS'	'SINGLE'	35	35	-1	''
'DIV'	'DOUBLE'	10	61	-1	''

'DIV'	'SINGLE'	6	33	-1	''
'EXP'	'DOUBLE'	25	25	-1	''
'EXP'	'SINGLE'	17	17	-1	''
'LOG'	'DOUBLE'	34	34	-1	''
'LOG'	'SINGLE'	21	21	-1	''
'MUL'	'DOUBLE'	11	11	-1	''
'MUL'	'SINGLE'	11	11	-1	''
'RECIP'	'DOUBLE'	27	27	-1	''
'RECIP'	'SINGLE'	20	20	-1	''
'RELOP'	'DOUBLE'	1	3	-1	''
'RELOP'	'SINGLE'	1	3	-1	''
'RSQRT'	'DOUBLE'	36	36	-1	''
'RSQRT'	'SINGLE'	26	26	-1	''
'SIN'	'SINGLE'	36	36	-1	''
'SQRT'	'DOUBLE'	30	57	-1	''
'SQRT'	'SINGLE'	16	28	-1	''

Generate Code

```
makehdl('sfir_single/symmetric_fir','FloatingPointTargetConfiguration',fpconfig, ...
        'TargetDirectory','C:/FloatingPoint/hdlsrc','SynthesisToolChipFamily','Arria10')
```

```
### Generating HDL for 'sfir_single/symmetric_fir'.
### Starting HDL check.
### Using C:\Altera\16.0\quartus\bin64\qmegawiz for the selected floating point IP library.
### The code generation and optimization options you have chosen have introduced additional pipe
### The delay balancing feature has automatically inserted matching delays for compensation.
### The DUT requires an initial pipeline setup latency. Each output port experiences these addit
### Output port 0: 30 cycles.
### Output port 1: 30 cycles.
### Generating Altera(R) megafunction: altfp_add_single for latency of 6.
### Found an existing generated file in a previous session: (C:\FloatingPoint\hdlsrc\sfir_single
### Done.
### Generating Altera(R) megafunction: altfp_mul_single for latency of 11.
### Found an existing generated file in a previous session: (C:\FloatingPoint\hdlsrc\sfir_single
### Done.
### Begin VHDL Code Generation for 'sfir_single'.
### Working on sfir_single/symmetric_fir as C:\FloatingPoint\hdlsrc\sfir_single\symmetric_fir.vh
### Generating package file C:\FloatingPoint\hdlsrc\sfir_single\symmetric_fir_pkg.vhd.
### Creating HDL Code Generation Check Report file://C:\FloatingPoint\hdlsrc\sfir_single\symmetr
### HDL check for 'sfir_single' complete with 0 errors, 7 warnings, and 0 messages.
### HDL code generation complete.
```

The latency of the ADDSUB IP is 6 and not the maximum latency value of 14.

The generated VHDL code is saved in the `hdlsrc` folder.

Tips

Before using this function, create a floating-point target configuration object for the floating-point library that you specify. Select library as Altera Megafunctions (ALTERA FP FUNCTIONS), Altera Megafunctions (ALTFP), or Xilinx LogiCORE.

This example creates a floating-point target configuration for the Altera Megafunctions (ALTFP) library.

```
fpconfig = hdlcoder.createFloatingPointTargetConfig('ALTFP');
```

See Also

`hdlcoder.FloatingPointTargetConfig`

Topics

“FPGA Floating-Point Library IP Mapping”

“Share Floating-Point IPs”

“Generate HDL Code for FPGA Floating-Point Target Libraries”

“Customize Floating-Point IP Configuration”

Introduced in R2016b

hdlcoder.WorkflowConfig class

Package: hdlcoder

Configure HDL code generation and deployment workflows

Description

Use the `hdlcoder.WorkflowConfig` object to set HDL workflow options for the `hdlcoder.runWorkflow` function. You can customize the `hdlcoder.WorkflowConfig` object for these workflows:

- Generic ASIC/FPGA
- FPGA-in-the-Loop (requires HDL Verifier)
- FPGA Turnkey
- IP Core Generation
- Simulink Real-Time FPGA I/O (requires Simulink Real-Time™)

A best practice is to use the HDL Workflow Advisor to configure the workflow, and then export a workflow script. The commands in the workflow script create and configure the `hdlcoder.WorkflowConfig` object. See “Run HDL Workflow with a Script”.

Construction

`hdlcoder.WorkflowConfig(Name, Value)` creates a workflow configuration object for you to specify your HDL code generation and deployment workflows, with additional options specified by one or more `Name, Value` pair arguments.

Name-Value Pair Arguments

Specify optional comma-separated pairs of `Name, Value` arguments. `Name` is the argument name and `Value` is the corresponding value. `Name` must appear inside quotes. You can specify several name and value pair arguments in any order as `Name1, Value1, ..., NameN, ValueN`.

SynthesisTool — Synthesis tool name

'Xilinx Vivado' (default) | 'Altera QUARTUS II' | 'Xilinx ISE'

Name of the synthesis tool, specified as a character vector.

Example: `'SynthesisTool', 'Altera QUARTUS II'` creates a workflow configuration object with `'Altera QUARTUS II'` as the synthesis tool and `'Generic ASIC/FPGA'` as the target workflow.

TargetWorkflow — Specify the target workflow

'Generic ASIC/FPGA' (default) | 'FPGA Turnkey' | 'IP Core Generation' | 'FPGA-in-the-Loop' | 'Simulink Real-Time FPGA I/O'

Target workflow for HDL code generation, specified as a character vector.

Example: `'TargetWorkflow', 'IP Core Generation'` creates a workflow configuration object with `'Xilinx Vivado'` as the synthesis tool and `'IP Core Generation'` as the target workflow.

Properties

Generic ASIC/FPGA Workflow

ProjectFolder — Folder for generated project files

' ' (default) | character vector

Path to the folder where your generated project files are saved, specified as a character vector.

Example: 'project_file_folder'

Objective — Synthesis tool objective

hdlcoder.Objective.None (default) | hdlcoder.Objective.SpeedOptimized |
hdlcoder.Objective.AreaOptimized | hdlcoder.Objective.CompileOptimized

High-level synthesis tool objective, specified as one of these values.

hdlcoder.Objective.None (default)	Do not generate additional Tcl commands.
hdlcoder.Objective.SpeedOptimized	Generate synthesis tool Tcl commands to optimize for speed.
hdlcoder.Objective.AreaOptimized	Generate synthesis tool Tcl commands to optimize for area.
hdlcoder.Objective.CompileOptimized	Generate synthesis tool Tcl commands to optimize for compilation time.

If your synthesis tool is Xilinx ISE and your target workflow is Generic ASIC/FPGA or FPGA Turnkey, set the Objective to hdlcoder.Objective.None.

For the tool-specific Tcl commands that are added to the synthesis project creation Tcl script, see “Synthesis Objective to Tcl Command Mapping”.

RunTaskGenerateRTLCodeAndTestbench — Enable task to generate code and test bench

true (default) | false

Enable or disable workflow task to generate code and test bench, specified as a logical.

In the HDL Workflow Advisor, this task is the **HDL Workflow Advisor > HDL Code Generation > Generate RTL Code and Testbench** task.

RunTaskVerifyWithHDLCosimulation — Enable task to verify generated code with HDL cosimulation

true (default) | false

Enable or disable task to verify the generated code with HDL cosimulation, specified as a logical. This option takes effect only when GenerateCosimulationModel is true.

In the HDL Workflow Advisor, this task is the **HDL Workflow Advisor > HDL Code Generation > Verify with HDL Cosimulation** task.

RunTaskCreateProject — Enable task to create synthesis tool project

true (default) | false

Enable or disable task to create a synthesis tool project, specified as a logical.

In the HDL Workflow Advisor, this task is the **HDL Workflow Advisor > FPGA Synthesis and Analysis > Create Project** task.

RunTaskPerformLogicSynthesis — Enable task to launch synthesis tool and run logic synthesis

true (default) | false

Enable or disable task to launch the synthesis tool and run logic synthesis, specified as a `logical`. This task is available only when your synthesis tool is Xilinx ISE or Altera Quartus II.

In the HDL Workflow Advisor, this task is the **HDL Workflow Advisor > FPGA Synthesis and Analysis > Perform Synthesis and P/R > Perform Logic Synthesis** task.

RunTaskPerformMapping — Enable task to map synthesized logic to target device

true (default) | false

Enable or disable task to map the synthesized logic to the target device, specified as a `logical`. This task is available only when your synthesis tool is Xilinx ISE or Altera Quartus II.

In the HDL Workflow Advisor, this task is the **HDL Workflow Advisor > FPGA Synthesis and Analysis > Perform Synthesis and P/R > Perform Mapping** task.

RunTaskPerformPlaceAndRoute — Enable task to run place and route process

true (default) | false

Enable or disable task to run the place and route process, specified as a `logical`. This task is available only when your synthesis tool is Xilinx ISE or Altera Quartus II.

In the HDL Workflow Advisor, this task is the **HDL Workflow Advisor > FPGA Synthesis and Analysis > Perform Synthesis and P/R > Perform Place and Route** task.

RunTaskRunSynthesis — Enable task to launch Xilinx Vivado and run synthesis

true (default) | false

Enable or disable task to launch Xilinx Vivado and run synthesis, specified as a `logical`. This task is available only when your synthesis tool is Xilinx Vivado.

In the HDL Workflow Advisor, this task is the **HDL Workflow Advisor > FPGA Synthesis and Analysis > Perform Synthesis and P/R > Run Synthesis** task.

RunTaskRunImplementation — Enable task to launch Xilinx Vivado and run implementation

true (default) | false

Enable or disable task to launch Xilinx Vivado and run the implementation step, specified as a `logical`. This task is available only when your synthesis tool is Xilinx Vivado.

In the HDL Workflow Advisor, this task is the **HDL Workflow Advisor > FPGA Synthesis and Analysis > Perform Synthesis and P/R > Run Implementation** task.

RunTaskAnnotateModelWithSynthesisResult — Enable task to analyze timing information and highlight critical paths

true (default) | false

Enable or disable task to analyze pre- or post-routing timing information and highlight critical paths in your model, specified as a `logical`. This task is available only when the target workflow is Generic ASIC/FPGA.

In the HDL Workflow Advisor, this task is the **HDL Workflow Advisor > FPGA Synthesis and Analysis > Annotate Model with Synthesis Result** task.

GenerateRTLCode — Generate HDL code

true (default) | false

Option to generate HDL code in the target language, specified as a logical.

In the HDL Workflow Advisor, this option is part of the **HDL Workflow Advisor > HDL Code Generation > Generate RTL Code and Testbench** task.

GenerateTestbench — Generate HDL test bench

false (default) | true

Option to generate an HDL test bench in the target language, specified as a logical.

In the HDL Workflow Advisor, this option is part of the **HDL Workflow Advisor > HDL Code Generation > Generate RTL Code and Testbench** task.

GenerateValidationModel — Generate validation model

false (default) | true

Generate a validation model, specified as a logical.

In the HDL Workflow Advisor, this option is part of the **HDL Workflow Advisor > HDL Code Generation > Generate RTL Code and Testbench** task.

AdditionalProjectCreationTclFiles — Additional project creation Tcl files to include in your synthesis project

' ' (default) | character vector

Additional project creation Tcl files that you want to include in your synthesis project, specified as a character vector.

In the HDL Workflow Advisor, this option is part of the **HDL Workflow Advisor > FPGA Synthesis and Analysis > Create Project** task.

Example: 'L:\file1.tcl;L:\file2.tcl;'

SkipPreRouteTimingAnalysis — Skip pre-route timing analysis logical

false (default) | true

Skip pre-route timing analysis, specified as a logical. If your tool does not support early timing estimation, set to true.

When you enable this option, CriticalPathSource is set to 'post-route'

In the HDL Workflow Advisor, this option is part of the **HDL Workflow Advisor > FPGA Synthesis and Analysis > Perform Synthesis and P/R > Perform Mapping** task.

IgnorePlaceAndRouteErrors — Ignore place and route errors

false (default) | true

Ignore place and route errors, specified as a logical.

In the HDL Workflow Advisor, this option is part of the **HDL Workflow Advisor > FPGA Synthesis and Analysis > Perform Synthesis and P/R > Perform Place and route** task.

CriticalPathSource — Critical path source

'pre-route' (default) | 'post-route'

Critical path source, specified as a character vector.

In the HDL Workflow Advisor, this option is part of the **HDL Workflow Advisor > FPGA Synthesis and Analysis > Perform Synthesis and P/R > Perform Mapping** task.

CriticalPathNumber — Number of critical paths to annotate

1 (default) | 2 | 3

Number of critical paths to annotate, specified as a positive integer from 1 to 3.

In the HDL Workflow Advisor, this option is part of the **HDL Workflow Advisor > FPGA Synthesis and Analysis > Annotate Model with Synthesis Result** task.

ShowAllPaths — Show all critical paths

false (default) | true

Show all critical paths, including duplicate paths, specified as a logical.

In the HDL Workflow Advisor, this option is part of the **HDL Workflow Advisor > FPGA Synthesis and Analysis > Annotate Model with Synthesis Result** task.

ShowDelayData — Annotate cumulative timing delay on each critical path

true (default) | false

Annotate the cumulative timing delay on each critical path, specified as a logical.

In the HDL Workflow Advisor, this option is part of the **HDL Workflow Advisor > FPGA Synthesis and Analysis > Annotate Model with Synthesis Result** task.

ShowUniquePaths — Show only the first instance of a critical path

false (default) | true

Show only the first instance of a critical path that is duplicated, specified as a logical.

In the HDL Workflow Advisor, this option is part of the **HDL Workflow Advisor > FPGA Synthesis and Analysis > Annotate Model with Synthesis Result** task.

ShowEndsOnly — Show only endpoints of each critical path

false (default) | true

Show the endpoints of each critical path, omitting connecting signal lines, specified as a logical.

In the HDL Workflow Advisor, this option is part of the **HDL Workflow Advisor > FPGA Synthesis and Analysis > Annotate Model with Synthesis Result** task.

FPGA-in-the-Loop**ProjectFolder — Folder for generated project files**

' ' (default) | character vector

Path to the folder where your generated project files are saved, specified as a character vector.

Example: 'project_file_folder'

RunTaskGenerateRTLCodeAndTestbench — Enable task to generate code and test bench

true (default) | false

Enable or disable workflow task to generate code and test bench, specified as a logical.

In the HDL Workflow Advisor, this task is the **HDL Workflow Advisor > HDL Code Generation > Generate RTL Code and Testbench** task.

RunTaskVerifyWithHDLCosimulation — Enable task to verify generated code with HDL cosimulation

true (default) | false

Enable or disable task to verify the generated code with HDL cosimulation, specified as a logical. This option takes effect only when `GenerateCosimulationModel` is true.

In the HDL Workflow Advisor, this task is the **HDL Workflow Advisor > HDL Code Generation > Verify with HDL Cosimulation** task.

RunTaskBuildFPGAInTheLoop — Enable task to generate a model that contains a FIL block and a testbench around the FIL block

true (default) | false

Enable or disable task to generate a model that contains a FIL block and a testbench around the FIL block specified as a logical.

In the HDL Workflow Advisor, this task is the **HDL Workflow Advisor > FPGA-in-the-Loop Implementation > Build FPGA-in-the-Loop** task.

GenerateRTLCode — Generate HDL code

true (default) | false

Option to generate HDL code in the target language, specified as a logical.

In the HDL Workflow Advisor, this option is part of the **HDL Workflow Advisor > HDL Code Generation > Generate RTL Code and Testbench** task.

GenerateTestbench — Generate HDL test bench

false (default) | true

Option to generate an HDL test bench in the target language, specified as a logical.

In the HDL Workflow Advisor, this option is part of the **HDL Workflow Advisor > HDL Code Generation > Generate RTL Code and Testbench** task.

GenerateValidationModel — Generate validation model

false (default) | true

Generate a validation model, specified as a logical.

In the HDL Workflow Advisor, this option is part of the **HDL Workflow Advisor > HDL Code Generation > Generate RTL Code and Testbench** task.

IPAddress — IP address of FPGA board`'192.168.0.2'` (default) | character vector

IP address of the FPGA board, specified as a character vector. Default address is `'192.168.0.2'`.

In the HDL Workflow Advisor, this option is part of the **HDL Workflow Advisor > FPGA-in-the-Loop Implementation > Set FPGA-in-the-Loop Options** task.

MACAddress — MAC address of FPGA board`'00-0A-35-02-21-8A'` (default) | character vector

MAC address of the FPGA board, specified as a character vector, for example `'00-0A-35-02-21-8A'`. In most cases, you do not have to change the Board MAC address. If you want to connect more than one FPGA board to a single computer, specify a unique MAC address for each additional board.

In the HDL Workflow Advisor, this option is part of the **HDL Workflow Advisor > FPGA-in-the-Loop Implementation > Set FPGA-in-the-Loop Options** task.

SourceFiles — Additional HDL source files for verification`''` (default) | character vector

Additional source files for the HDL design that you want to verify on the FPGA board, specified as a character vector.

In the HDL Workflow Advisor, this option is part of the **HDL Workflow Advisor > FPGA-in-the-Loop Implementation > Set FPGA-in-the-Loop Options** task.

Connection — JTAG or Ethernet connection`'JTAG'` (default) | `'Ethernet'`

Ethernet or JTAG connection type to the FPGA development board, specified as a character vector.

In the HDL Workflow Advisor, this option is part of the **HDL Workflow Advisor > FPGA-in-the-Loop Implementation > Set FPGA-in-the-Loop Options** task.

RunExternalBuild — Run build process externally`true` (default) | `false`

Option to run build process in parallel with MATLAB, specified as a `logical`. If this option is disabled, you cannot use MATLAB until the build is finished.

FPGA Turnkey Workflow**ProjectFolder — Folder for generated project files**`''` (default) | character vector

Path to the folder where your generated project files are saved, specified as a character vector.

Example: `'project_file_folder'`

Objective — Synthesis tool objective`hdlcoder.Objective.None` (default) | `hdlcoder.Objective.SpeedOptimized` | `hdlcoder.Objective.AreaOptimized` | `hdlcoder.Objective.CompileOptimized`

High-level synthesis tool objective, specified as one of these values.

<code>hdlcoder.Objective.None</code> (default)	Do not generate additional Tcl commands.
<code>hdlcoder.Objective.SpeedOptimized</code>	Generate synthesis tool Tcl commands to optimize for speed.
<code>hdlcoder.Objective.AreaOptimized</code>	Generate synthesis tool Tcl commands to optimize for area.
<code>hdlcoder.Objective.CompileOptimized</code>	Generate synthesis tool Tcl commands to optimize for compilation time.

If your synthesis tool is Xilinx ISE and your target workflow is Generic ASIC/FPGA or FPGA Turnkey, set the `Objective` to `hdlcoder.Objective.None`.

For the tool-specific Tcl commands that are added to the synthesis project creation Tcl script, see “Synthesis Objective to Tcl Command Mapping”.

RunTaskGenerateRTLCode — Enable task to generate RTL code and HDL top-level wrapper
`true` (default) | `false`

Enable or disable workflow task to generate RTL code and an HDL top-level wrapper, specified as a `logical`. When enabled, this task also generates a constraint file that contains pin mapping information and clock constraints.

In the HDL Workflow Advisor, this task is the **HDL Workflow Advisor > HDL Code Generation > Generate RTL Code** task.

RunTaskCreateProject — Enable task to create synthesis tool project
`true` (default) | `false`

Enable or disable task to create a synthesis tool project, specified as a `logical`.

In the HDL Workflow Advisor, this task is the **HDL Workflow Advisor > FPGA Synthesis and Analysis > Create Project** task.

RunTaskPerformLogicSynthesis — Enable task to launch synthesis tool and run logic synthesis
`true` (default) | `false`

Enable or disable task to launch the synthesis tool and run logic synthesis, specified as a `logical`. This task is available only when your synthesis tool is Xilinx ISE or Altera Quartus II.

In the HDL Workflow Advisor, this task is the **HDL Workflow Advisor > FPGA Synthesis and Analysis > Perform Synthesis and P/R > Perform Logic Synthesis** task.

RunTaskPerformMapping — Enable task to map synthesized logic to target device
`true` (default) | `false`

Enable or disable task to map the synthesized logic to the target device, specified as a `logical`. This task is available only when your synthesis tool is Xilinx ISE or Altera Quartus II.

In the HDL Workflow Advisor, this task is the **HDL Workflow Advisor > FPGA Synthesis and Analysis > Perform Synthesis and P/R > Perform Mapping** task.

RunTaskPerformPlaceAndRoute — Enable task to run place and route process
`true` (default) | `false`

Enable or disable task to run the place and route process, specified as a `logical`. This task is available only when your synthesis tool is Xilinx ISE or Altera Quartus II.

In the HDL Workflow Advisor, this task is the **HDL Workflow Advisor > FPGA Synthesis and Analysis > Perform Synthesis and P/R > Perform Place and Route** task.

RunTaskRunSynthesis — Enable task to launch Xilinx Vivado and run synthesis

`true` (default) | `false`

Enable or disable task to launch Xilinx Vivado and run synthesis, specified as a `logical`. This task is available only when your synthesis tool is Xilinx Vivado.

In the HDL Workflow Advisor, this task is the **HDL Workflow Advisor > FPGA Synthesis and Analysis > Perform Synthesis and P/R > Run Synthesis** task.

RunTaskRunImplementation — Enable task to launch Xilinx Vivado and run implementation

`true` (default) | `false`

Enable or disable task to launch Xilinx Vivado and run the implementation step, specified as a `logical`. This task is available only when your synthesis tool is Xilinx Vivado.

In the HDL Workflow Advisor, this task is the **HDL Workflow Advisor > FPGA Synthesis and Analysis > Perform Synthesis and P/R > Run Implementation** task.

RunTaskGenerateProgrammingFile — Enable task to generate FPGA programming file

`true` (default) | `false`

Enable or disable task to generate an FPGA programming file, specified as a `logical`.

In the HDL Workflow Advisor, this task is the **HDL Workflow Advisor > Download to Target > Generate Programming File** task.

RunTaskProgramTargetDevice — Enable task to program target device

`true` (default) | `false`

Enable or disable task to download the FPGA programming file to the target device, specified as a `logical`. This task is available only when the target workflow is FPGA Turnkey.

In the HDL Workflow Advisor, this task is the **HDL Workflow Advisor > Download to Target > Program Target Device** task.

AdditionalProjectCreationTclFiles — Additional project creation Tcl files to include in your synthesis project

`' '` (default) | character vector

Additional project creation Tcl files that you want to include in your synthesis project, specified as a character vector.

In the HDL Workflow Advisor, this option is part of the **HDL Workflow Advisor > FPGA Synthesis and Analysis > Create Project** task.

Example: `'L:\file1.tcl;L:\file2.tcl;'`

SkipPreRouteTimingAnalysis — Skip pre-route timing analysis logical

`false` (default) | `true`

Skip pre-route timing analysis, specified as a `logical`. If your tool does not support early timing estimation, set to `true`.

When this option is enabled, `CriticalPathSource` is set to `'post-route'`

In the HDL Workflow Advisor, this option is part of the **HDL Workflow Advisor > FPGA Synthesis and Analysis > Perform Synthesis and P/R > Perform Mapping** task.

IgnorePlaceAndRouteErrors — Ignore place and route errors

`false` (default) | `true`

Ignore place and route errors, specified as a `logical`.

In the HDL Workflow Advisor, this option is part of the **HDL Workflow Advisor > FPGA Synthesis and Analysis > Perform Synthesis and P/R > Perform Place and route** task.

IP Core Generation Workflow

ProjectFolder — Folder for generated project files

`' '` (default) | character vector

Path to the folder where your generated project files are saved, specified as a character vector.

Example: `'project_file_folder'`

ReferenceDesignToolVersion — Current reference design tool version

character vector

Current reference design tool version, specified as a character vector, for example `'2017.4'`. By default, the code generator selects a reference design tool version that is compatible with the current supported tool version. It is change this default reference design tool version, HDL Coder generates an error.

In the HDL Workflow Advisor, this setting is in the **HDL Workflow Advisor > Set Target > Set Target Reference Design** task.

IgnoreToolVersionMismatch — Ignore mismatch in reference design tool version

`false` (default) | `true`

Whether you want the code generator to ignore a mismatch between the reference design tool version and the supported tool version, specified as a `logical`. By default, if there is a tool version mismatch, HDL Coder generates an error. If you set this option to `true`, HDL Coder generates a warning instead.

In the HDL Workflow Advisor, this setting is in the **HDL Workflow Advisor > Set Target > Set Target Reference Design** task.

RunTaskGenerateRTLCodeAndIPCore — Enable task to generate code and IP core

`true` (default) | `false`

Enable or disable workflow task to generate code and IP core for embedded system, specified as a `logical`.

In the HDL Workflow Advisor, this task is the **HDL Workflow Advisor > HDL Code Generation > Generate RTL Code and IP Core** task.

RunTaskCreateProject — Enable task to create embedded system tool project`true (default) | false`

Enable or disable workflow task to create an embedded system tool project, specified as a `logical`.

In the HDL Workflow Advisor, this task is the **HDL Workflow Advisor > Embedded System Integration > Create Project** task.

RunTaskGenerateSoftwareInterfaceModel — Enable task to generate software interface model`true (default) | false`

Enable or disable workflow task to generate a software interface model with IP core driver blocks for embedded C code generation, specified as a `logical`.

In the HDL Workflow Advisor, this task is the **HDL Workflow Advisor > Embedded System Integration > Generate Software Interface Model** task.

RunTaskBuildFPGABitstream — Enable task to generate bitstream for embedded system`true (default) | false`

Enable or disable workflow task to generate a bitstream for the embedded system, specified as a `logical`.

In the HDL Workflow Advisor, this task is the **HDL Workflow Advisor > Embedded System Integration > Build FPGA Bitstream** task.

RunTaskProgramTargetDevice — Enable task to program connected target device`false (default) | true`

Enable or disable workflow task to program the connected target device, specified as a `logical`.

In the HDL Workflow Advisor, this task is the **HDL Workflow Advisor > Embedded System Integration > Program Target Device** task.

IPCoreRepository — IP core repository folder path`' ' (default) | character vector`

Full path to an IP core repository folder, specified as a character vector. The coder copies the generated IP core into the IP repository folder.

Example: `'L:\sandbox\work\IPfolder'`

GenerateIPCoreReport — Generate HTML documentation for the IP core`true (default) | false`

Option to generate HTML documentation for the IP core, specified as a `logical`. For details, see “Custom IP Core Report”.

Objective — Synthesis tool objective`hdlcoder.Objective.None (default) | hdlcoder.Objective.SpeedOptimized | hdlcoder.Objective.AreaOptimized | hdlcoder.Objective.CompileOptimized`

High-level synthesis tool objective, specified as one of these values.

<code>hdlcoder.Objective.None</code> (default)	Do not generate additional Tcl commands.
<code>hdlcoder.Objective.SpeedOptimized</code>	Generate synthesis tool Tcl commands to optimize for speed.
<code>hdlcoder.Objective.AreaOptimized</code>	Generate synthesis tool Tcl commands to optimize for area.
<code>hdlcoder.Objective.CompileOptimized</code>	Generate synthesis tool Tcl commands to optimize for compilation time.

If your synthesis tool is Xilinx ISE and your target workflow is Generic ASIC/FPGA or FPGA Turnkey, set the `Objective` to `hdlcoder.Objective.None`.

For the tool-specific Tcl commands that are added to the synthesis project creation Tcl script, see “Synthesis Objective to Tcl Command Mapping”.

EnableIPCaching — Create IP cache to reduce reference design synthesis time

`false` (default) | `true`

Enable or disable IP caching, specified as a `logical`. When you enable IP caching, the code generator creates an IP cache. The IP Core Generation workflow uses an out-of-context (OOC) workflow. This workflow synthesizes the IP in the reference design out of context from the top-level design. You can reuse this cache in subsequent project runs, which reduces reference design synthesis time. To learn more, see “IP Caching for Faster Reference Design Synthesis”.

In the HDL Workflow Advisor, you can specify this setting in the **Create Project** task.

OperatingSystem — Operating system

`' '` (default) | character vector

Operating system for embedded processor, specified as a character vector. The operating system is board-specific.

AddLinuxDeviceDriver — Add IP core device driver

`false` (default) | `true`

Option to insert the IP core node into the operating system device tree on the SD card on your board, specified as a `logical`. This option also restarts the operating system and adds the IP core driver as a loadable kernel module.

To use this option, your board must be connected.

RunExternalBuild — Run build process externally

`true` (default) | `false`

Option to run build process in parallel with MATLAB, specified as a `logical`. If this option is disabled, you cannot use MATLAB until the build is finished.

ReportTimingFailure — Report timing failures as warnings or errors

`hdlcoder.ReportTimingFailure.Error` (default) |
`hdlcoder.ReportTimingFailure.Warning`

Select whether to report timing failures when generating the FPGA bitstream, specified as one of these values:

<code>hdlcoder.ReportTimingFailure.Error</code> (default)	Report timing failures as errors by default.
<code>hdlcoder.ReportTimingFailure.Warning</code>	Report timing failures as errors instead of warnings. Use this option if you have implemented the custom logic to resolve timing violations in your design.

TclFileForSynthesisBuild — Use custom or default synthesis tool build script

`hdlcoder.BuildOption.Default` (default) | `hdlcoder.BuildOption.Custom`

Select whether to use a custom or default synthesis tool build script, specified as one of these values:

<code>hdlcoder.BuildOption.Default</code> (default)	Use the default build script.
<code>hdlcoder.BuildOption.Custom</code>	Use a custom build script instead of the default build script.

CustomBuildTclFile — Custom synthesis tool build script file

`''` (default) | character vector

Full path to a custom synthesis tool build Tcl script file, specified as a character vector. The contents of your custom Tcl file are inserted between the Tcl commands that open and close the project. If `TclFileForSynthesisBuild` is set to `hdlcoder.BuildOption.Custom`, you must specify a file.

If you want to generate a bitstream, the bitstream generation Tcl command must refer to the top file wrapper name and location either directly or implicitly. For example, this Xilinx Vivado Tcl command generates a bitstream and implicitly refers to the top file name and location:

```
launch_runs impl_1 -to_step write_bitstream
```

Example: `'C:\Temp\work\build.tcl'`

Simulink Real-Time FPGA I/O

ProjectFolder — Folder for generated project files

`''` (default) | character vector

Path to the folder where your generated project files are saved, specified as a character vector.

Example: `'project_file_folder'`

ReferenceDesignToolVersion — Current reference design tool version

character vector

Current reference design tool version, specified as a character vector, for example `'2017.4'`. By default, the code generator selects a reference design tool version that is compatible with the current supported tool version. It is change this default reference design tool version, HDL Coder generates an error.

In the HDL Workflow Advisor, this setting is in the **HDL Workflow Advisor > Set Target > Set Target Reference Design** task.

IgnoreToolVersionMismatch — Ignore mismatch in reference design tool version

`false` (default) | `true`

Whether you want the code generator to ignore a mismatch between the reference design tool version and the supported tool version, specified as a `logical`. By default, if there is a tool version

mismatch, HDL Coder generates an error. If you set this option to `true`, HDL Coder generates a warning instead.

In the HDL Workflow Advisor, this setting is in the **HDL Workflow Advisor > Set Target > Set Target Reference Design** task.

RunTaskGenerateRTLCodeAndIPCore — Enable task to generate code and IP core

`true` (default) | `false`

Enable or disable workflow task to generate code and IP core for embedded system, specified as a `logical`.

In the HDL Workflow Advisor, this task is the **HDL Workflow Advisor > HDL Code Generation > Generate RTL Code and IP Core** task.

RunTaskGenerateRTLCode — Enable task to generate RTL code and HDL top-level wrapper

`true` (default) | `false`

Enable or disable workflow task to generate RTL code and an HDL top-level wrapper, specified as a `logical`. When enabled, this task also generates a constraint file that contains pin mapping information and clock constraints.

In the HDL Workflow Advisor, this task is the **HDL Workflow Advisor > HDL Code Generation > Generate RTL Code** task.

RunTaskCreateProject — Enable task to create embedded system tool project

`true` (default) | `false`

Enable or disable workflow task to create an embedded system tool project, specified as a `logical`.

In the HDL Workflow Advisor, this task is the **HDL Workflow Advisor > Embedded System Integration > Create Project** task.

RunTaskPerformLogicSynthesis — Enable task to launch synthesis tool and run logic synthesis

`true` (default) | `false`

Enable or disable task to launch the synthesis tool and run logic synthesis, specified as a `logical`. This task is available only when your synthesis tool is Xilinx ISE or Altera Quartus II.

In the HDL Workflow Advisor, this task is the **HDL Workflow Advisor > FPGA Synthesis and Analysis > Perform Synthesis and P/R > Perform Logic Synthesis** task.

RunTaskPerformMapping — Enable task to map synthesized logic to target device

`true` (default) | `false`

Enable or disable task to map the synthesized logic to the target device, specified as a `logical`. This task is available only when your synthesis tool is Xilinx ISE or Altera Quartus II.

In the HDL Workflow Advisor, this task is the **HDL Workflow Advisor > FPGA Synthesis and Analysis > Perform Synthesis and P/R > Perform Mapping** task.

RunTaskPerformPlaceAndRoute — Enable task to run place and route process

`true` (default) | `false`

Enable or disable task to run the place and route process, specified as a `logical`. This task is available only when your synthesis tool is Xilinx ISE or Altera Quartus II.

In the HDL Workflow Advisor, this task is the **HDL Workflow Advisor > FPGA Synthesis and Analysis > Perform Synthesis and P/R > Perform Place and Route** task.

RunTaskGenerateProgrammingFile — Enable task to generate FPGA programming file

`true` (default) | `false`

Enable or disable task to generate an FPGA programming file, specified as a `logical`.

In the HDL Workflow Advisor, this task is the **HDL Workflow Advisor > Download to Target > Generate Programming File** task.

RunTaskGenerateSimulinkRealTimeInterface — Enable task to generate a model that contains an interface subsystem that you can plug into a Simulink Real-Time model

`true` (default) | `false`

Enable or disable task to generate a Simulink Real-Time model that contains an interface subsystem, specified as a `logical`.

In the HDL Workflow Advisor, this task is the **HDL Workflow Advisor > Download to Target > Generate Simulink Real-Time Interface** task.

Objective — Synthesis tool objective

`hdlcoder.Objective.None` (default) | `hdlcoder.Objective.SpeedOptimized` | `hdlcoder.Objective.AreaOptimized` | `hdlcoder.Objective.CompileOptimized`

High-level synthesis tool objective, specified as one of these values.

<code>hdlcoder.Objective.None</code> (default)	Do not generate additional Tcl commands.
<code>hdlcoder.Objective.SpeedOptimized</code>	Generate synthesis tool Tcl commands to optimize for speed.
<code>hdlcoder.Objective.AreaOptimized</code>	Generate synthesis tool Tcl commands to optimize for area.
<code>hdlcoder.Objective.CompileOptimized</code>	Generate synthesis tool Tcl commands to optimize for compilation time.

If your synthesis tool is Xilinx ISE and your target workflow is Generic ASIC/FPGA or FPGA Turnkey, set the `Objective` to `hdlcoder.Objective.None`.

For the tool-specific Tcl commands that are added to the synthesis project creation Tcl script, see “Synthesis Objective to Tcl Command Mapping”.

AdditionalProjectCreationTclFiles — Additional project creation Tcl files to include in your synthesis project

`''` (default) | character vector

Additional project creation Tcl files that you want to include in your synthesis project, specified as a character vector.

In the HDL Workflow Advisor, this option is part of the **HDL Workflow Advisor > FPGA Synthesis and Analysis > Create Project** task.

Example: 'L:\file1.tcl;L:\file2.tcl;'

SkipPreRouteTimingAnalysis — Skip pre-route timing analysis logical

false (default) | true

Skip pre-route timing analysis, specified as a logical. If your tool does not support early timing estimation, set to true.

When you enable this option, CriticalPathSource is set to 'post-route'

In the HDL Workflow Advisor, this option is part of the **HDL Workflow Advisor > FPGA Synthesis and Analysis > Perform Synthesis and P/R > Perform Mapping** task.

IgnorePlaceAndRouteErrors — Ignore place and route errors

false (default) | true

Ignore place and route errors, specified as a logical.

In the HDL Workflow Advisor, this option is part of the **HDL Workflow Advisor > FPGA Synthesis and Analysis > Perform Synthesis and P/R > Perform Place and route** task.

RunTaskBuildFPGABitstream — Enable task to generate bitstream for embedded system

true (default) | false

Enable or disable workflow task to generate a bitstream for the embedded system, specified as a logical.

In the HDL Workflow Advisor, this task is the **HDL Workflow Advisor > Embedded System Integration > Build FPGA Bitstream** task.

ReportTimingFailure — Report timing failures as warnings or errors

hdlcoder.ReportTimingFailure.Error (default) |
hdlcoder.ReportTimingFailure.Warning

Select whether to report timing failures when generating the FPGA bitstream, specified as one of these values:

hdlcoder.ReportTimingFailure.Error (default)	Report timing failures as errors by default.
hdlcoder.ReportTimingFailure.Warning	Report timing failures as errors instead of warnings. Use this option if you have implemented the custom logic to resolve timing violations in your design.

Methods

export	Generate MATLAB script that recreates the workflow configuration
setAllTasks	Enable all tasks in workflow
clearAllTasks	Disable all tasks in workflow
validate	Check property values in HDL Workflow CLI configuration object

Examples

Configure and Run Generic ASIC/FPGA Workflow with a Script

This example shows how to configure and run an exported HDL workflow script.

To generate an HDL workflow script, configure and run the HDL Workflow Advisor with your Simulink design, then export the script.

This script is a generic ASIC/FPGA workflow script that targets a Xilinx Virtex® 7 device and uses the Xilinx Vivado synthesis tool.

Open and view your exported HDL workflow script.

```
% Export Workflow Configuration Script
% Generated with MATLAB 9.5 (R2018b Prerelease) at 14:42:37 on 29/03/2018
% This script was generated using the following parameter values:
%   Filename   : 'S:\generic_workflow_example.m'
%   Overwrite  : true
%   Comments   : true
%   Headers    : true
%   DUT        : 'sfir_fixed/symmetric_fir'
% To view changes after modifying the workflow, run the following command:
% >> hWC.export('DUT','sfir_fixed/symmetric_fir');
%-----

%% Load the Model
load_system('sfir_fixed');

%% Restore the Model to default HDL parameters
%hdlrestoreparams('sfir_fixed/symmetric_fir');

%% Model HDL Parameters
%% Set Model 'sfir_fixed' HDL parameters
hdlset_param('sfir_fixed', 'GenerateCoSimModel', 'ModelSim');
hdlset_param('sfir_fixed', 'GenerateHDLTestBench', 'off');
hdlset_param('sfir_fixed', 'HDLSubsystem', 'sfir_fixed/symmetric_fir');
hdlset_param('sfir_fixed', 'SynthesisTool', 'Xilinx Vivado');
hdlset_param('sfir_fixed', 'SynthesisToolChipFamily', 'Virtex7');
hdlset_param('sfir_fixed', 'SynthesisToolDeviceName', 'xc7vx485t');
hdlset_param('sfir_fixed', 'SynthesisToolPackageName', 'ffg1761');
hdlset_param('sfir_fixed', 'SynthesisToolSpeedValue', '-2');
hdlset_param('sfir_fixed', 'TargetDirectory', 'hdl_prj\hdlsrc');

%% Workflow Configuration Settings
% Construct the Workflow Configuration Object with default settings
hWC = hdlcoder.WorkflowConfig('SynthesisTool','Xilinx Vivado','TargetWorkflow','Generic ASIC/FPGA');

% Specify the top level project directory
hWC.ProjectFolder = 'hdl_prj';

% Set Workflow tasks to run
hWC.RunTaskGenerateRTLCodeAndTestbench = true;
hWC.RunTaskVerifyWithHDLCosimulation = true;
hWC.RunTaskCreateProject = true;
```

```

hWC.RunTaskRunSynthesis = true;
hWC.RunTaskRunImplementation = false;
hWC.RunTaskAnnotateModelWithSynthesisResult = true;

% Set properties related to 'RunTaskGenerateRTLCodeAndTestbench' Task
hWC.GenerateRTLCode = true;
hWC.GenerateTestbench = false;
hWC.GenerateValidationModel = false;

% Set properties related to 'RunTaskCreateProject' Task
hWC.Objective = hdlcoder.Objective.None;
hWC.AdditionalProjectCreationTclFiles = '';

% Set properties related to 'RunTaskRunSynthesis' Task
hWC.SkipPreRouteTimingAnalysis = false;

% Set properties related to 'RunTaskRunImplementation' Task
hWC.IgnorePlaceAndRouteErrors = false;

% Set properties related to 'RunTaskAnnotateModelWithSynthesisResult' Task
hWC.CriticalPathSource = 'pre-route';
hWC.CriticalPathNumber = 1;
hWC.ShowAllPaths = false;
hWC.ShowDelayData = true;
hWC.ShowUniquePaths = false;
hWC.ShowEndsOnly = false;

% Validate the Workflow Configuration Object
hWC.validate;

%% Run the workflow
hdlcoder.runWorkflow('sfir_fixed/symmetric_fir', hWC);

```

Optionally, edit the script.

For example, enable or disable tasks in the `hdlcoder.WorkflowConfig` object, `hWC`.

Run the HDL workflow script.

For example, if the script file name is `generic_workflow_example.m`, at the command line, enter:

```
generic_workflow_example.m
```

Configure and Run FPGA-in-the-Loop with a Script

This example shows how to configure and run an exported HDL workflow script.

To generate an HDL workflow script, configure and run the HDL Workflow Advisor with your Simulink design, then export the script.

This script is an FPGA-in-the-Loop workflow script that targets a Xilinx Virtex 5 development board and uses the Xilinx ISE synthesis tool.

Open and view your exported HDL workflow script.

```

%-----
% HDL Workflow Script

```

```

% Generated with MATLAB 9.5 (R2018b Prerelease) at 15:11:23 on 04/05/2018
% This script was generated using the following parameter values:
%   Filename   : 'C:\Users\ggnanase\Desktop\R2018b\18b_models\ipcore_timing_failure\hdlworkflow
%   Overwrite  : true
%   Comments   : true
%   Headers    : true
%   DUT        : 'sfir_fixed/symmetric_fir'
% To view changes after modifying the workflow, run the following command:
% >> hWC.export('DUT','sfir_fixed/symmetric_fir');
%-----

%% Load the Model
load_system('sfir_fixed');

%% Restore the Model to default HDL parameters
%hdlrestoreparams('sfir_fixed/symmetric_fir');

%% Model HDL Parameters
%% Set Model 'sfir_fixed' HDL parameters
hdlset_param('sfir_fixed', 'HDLSubsystem', 'sfir_fixed/symmetric_fir');
hdlset_param('sfir_fixed', 'SynthesisTool', 'Xilinx Vivado');
hdlset_param('sfir_fixed', 'SynthesisToolChipFamily', 'Kintex7');
hdlset_param('sfir_fixed', 'SynthesisToolDeviceName', 'xc7k325t');
hdlset_param('sfir_fixed', 'SynthesisToolPackageName', 'ffg900');
hdlset_param('sfir_fixed', 'SynthesisToolSpeedValue', '-2');
hdlset_param('sfir_fixed', 'TargetDirectory', 'hdl_prj\hdlsrc');
hdlset_param('sfir_fixed', 'TargetFrequency', 25);
hdlset_param('sfir_fixed', 'TargetPlatform', 'Xilinx Kintex-7 KC705 development board');
hdlset_param('sfir_fixed', 'Workflow', 'FPGA-in-the-Loop');

%% Workflow Configuration Settings
% Construct the Workflow Configuration Object with default settings
hWC = hdlcoder.WorkflowConfig('SynthesisTool','Xilinx Vivado','TargetWorkflow','FPGA-in-the-Loop

% Specify the top level project directory
hWC.ProjectFolder = 'hdl_prj';

% Set Workflow tasks to run
hWC.RunTaskGenerateRTLCodeAndTestbench = true;
hWC.RunTaskVerifyWithHDLCosimulation = false;
hWC.RunTaskBuildFPGAInTheLoop = true;

% Set properties related to 'RunTaskGenerateRTLCodeAndTestbench' Task
hWC.GenerateRTLCode = true;
hWC.GenerateTestbench = false;
hWC.GenerateValidationModel = false;

% Set properties related to 'RunTaskBuildFPGAInTheLoop' Task
hWC.IPAddress = '192.168.0.2';
hWC.MACAddress = '00-0A-35-02-21-8A';
hWC.SourceFiles = '';
hWC.Connection = 'Ethernet';
hWC.RunExternalBuild = true;

% Validate the Workflow Configuration Object
hWC.validate;

```



```
%% Run the workflow
hdlcoder.runWorkflow('sfir_fixed/symmetric_fir', hWC);
hdlcoder.runWorkflow('hdlcoderUARTServoControllerExample/UART_Servo_on_FPGA', hWC);
```

Optionally, edit the script.

For example, enable or disable tasks in the `hdlcoder.WorkflowConfig` object, `hWC`.

Run the HDL workflow script.

For example, if the script file name is `FIL_workflow_example.m`, at the command line, enter:

```
fil_workflow_example.m
```

Configure and Run FPGA Turnkey Workflow with a Script

This example shows how to configure and run an exported HDL workflow script.

To generate an HDL workflow script, configure and run the HDL Workflow Advisor with your Simulink design, then export the script.

This script is an FPGA Turnkey workflow script that targets a Xilinx Virtex 5 development board and uses the Xilinx ISE synthesis tool.

Open and view your exported HDL workflow script.

```
% Export Workflow Configuration Script
% Generated with MATLAB 8.6 (R2015b) at 14:24:32 on 08/07/2015
% Parameter Values:
%   Filename   : 'S:\turnkey_workflow_example.m'
%   Overwrite  : true
%   Comments   : true
%   Headers    : true
%   DUT        : 'hdlcoderUARTServoControllerExample/UART_Servo_on_FPGA'

%% Load the Model
load_system('hdlcoderUARTServoControllerExample');

%% Model HDL Parameters
% Set Model HDL parameters
hdlset_param('hdlcoderUARTServoControllerExample', ...
    'HDLSubsystem', 'hdlcoderUARTServoControllerExample/UART_Servo_on_FPGA');
hdlset_param('hdlcoderUARTServoControllerExample', ...
    'SynthesisTool', 'Xilinx ISE');
hdlset_param('hdlcoderUARTServoControllerExample', ...
    'SynthesisToolChipFamily', 'Virtex5');
hdlset_param('hdlcoderUARTServoControllerExample', ...
    'SynthesisToolDeviceName', 'xc5vsx50t');
hdlset_param('hdlcoderUARTServoControllerExample', ...
    'SynthesisToolPackageName', 'ff1136');
hdlset_param('hdlcoderUARTServoControllerExample', ...
    'SynthesisToolSpeedValue', '-1');
hdlset_param('hdlcoderUARTServoControllerExample', ...
    'TargetDirectory', 'hdl_prj\hdlsrc');
hdlset_param('hdlcoderUARTServoControllerExample', ...
    'TargetPlatform', 'Xilinx Virtex-5 ML506 development board');
```

```

hdlset_param('hdlcoderUARTServoControllerExample', 'Workflow', 'FPGA Turnkey');

% Set Inport HDL parameters
hdlset_param('hdlcoderUARTServoControllerExample/UART_Servo_on_FPGA/uart_rxd', ...
    'IOInterface', 'RS-232 Serial Port Rx');
hdlset_param('hdlcoderUARTServoControllerExample/UART_Servo_on_FPGA/uart_rxd', ...
    'IOInterfaceMapping', '[0]');

% Set Outputport HDL parameters
hdlset_param('hdlcoderUARTServoControllerExample/UART_Servo_on_FPGA/uart_txd', ...
    'IOInterface', 'RS-232 Serial Port Tx');
hdlset_param('hdlcoderUARTServoControllerExample/UART_Servo_on_FPGA/uart_txd', ...
    'IOInterfaceMapping', '[0]');

% Set Outputport HDL parameters
hdlset_param('hdlcoderUARTServoControllerExample/UART_Servo_on_FPGA/version', ...
    'IOInterface', 'LEDs General Purpose [0:7]');
hdlset_param('hdlcoderUARTServoControllerExample/UART_Servo_on_FPGA/version', ...
    'IOInterfaceMapping', '[0:3]');

% Set Outputport HDL parameters
hdlset_param('hdlcoderUARTServoControllerExample/UART_Servo_on_FPGA/pwm_output', ...
    'IOInterface', 'Expansion Headers J6 Pin 2-64 [0:31]');
hdlset_param('hdlcoderUARTServoControllerExample/UART_Servo_on_FPGA/pwm_output', ...
    'IOInterfaceMapping', '[0]');

% Set Outputport HDL parameters
hdlset_param('hdlcoderUARTServoControllerExample/UART_Servo_on_FPGA/servo_debug1', ...
    'IOInterface', 'Expansion Headers J6 Pin 2-64 [0:31]');
hdlset_param('hdlcoderUARTServoControllerExample/UART_Servo_on_FPGA/servo_debug1', ...
    'IOInterfaceMapping', '[1]');

% Set Outputport HDL parameters
hdlset_param('hdlcoderUARTServoControllerExample/UART_Servo_on_FPGA/servo_debug2', ...
    'IOInterface', 'Expansion Headers J6 Pin 2-64 [0:31]');
hdlset_param('hdlcoderUARTServoControllerExample/UART_Servo_on_FPGA/servo_debug2', ...
    'IOInterfaceMapping', '[2]');

%% Workflow Configuration Settings
% Construct the Workflow Configuration Object with default settings
hWC = hdlcoder.WorkflowConfig('SynthesisTool','Xilinx ISE', ...
    'TargetWorkflow','FPGA Turnkey');

% Specify the top level project directory
hWC.ProjectFolder = 'hdl_prj';

% Set Workflow tasks to run
hWC.RunTaskGenerateRTLCodeAndTestbench = true;
hWC.RunTaskVerifyWithHDLCosimulation = true;
hWC.RunTaskCreateProject = true;
hWC.RunTaskPerformLogicSynthesis = true;
hWC.RunTaskPerformMapping = true;
hWC.RunTaskPerformPlaceAndRoute = true;
hWC.RunTaskGenerateProgrammingFile = true;
hWC.RunTaskProgramTargetDevice = false;

% Set Properties related to Create Project Task

```

```

hWC.Objective = hdlcoder.Objective.None;
hWC.AdditionalProjectCreationTclFiles = '';

% Set Properties related to Perform Mapping Task
hWC.SkipPreRouteTimingAnalysis = true;

% Set Properties related to Perform Place and Route Task
hWC.IgnorePlaceAndRouteErrors = false;

% Validate the Workflow Configuration Object
hWC.validate;

%% Run the workflow
hdlcoder.runWorkflow('hdlcoderUARTServoControllerExample/UART_Servo_on_FPGA', hWC);

```

Optionally, edit the script.

For example, enable or disable tasks in the `hdlcoder.WorkflowConfig` object, `hWC`.

Run the HDL workflow script.

For example, if the script file name is `turnkey_workflow_example.m`, at the command line, enter:

```
turnkey_workflow_example.m
```

Configure and Run IP Core Generation Workflow with a Script

This example shows how to configure and run an exported HDL workflow script.

To generate an HDL workflow script, configure and run the HDL Workflow Advisor with your Simulink design, then export the script.

This script is an IP core generation workflow script that targets the Altera Cyclone V SoC development kit and uses the Altera Quartus II synthesis tool.

Open and view your exported HDL workflow script.

```

% Export Workflow Configuration Script
% Generated with MATLAB 8.6 (R2015b) at 14:42:16 on 08/07/2015
% Parameter Values:
%   Filename   : 'S:\ip_core_gen_workflow_example.m'
%   Overwrite  : true
%   Comments   : true
%   Headers    : true
%   DUT        : 'hdlcoder_led_blinking/led_counter'

%% Load the Model
load_system('hdlcoder_led_blinking');

%% Model HDL Parameters
% Set Model HDL parameters
hdlset_param('hdlcoder_led_blinking', ...
    'HDLSubsystem', 'hdlcoder_led_blinking/led_counter');
hdlset_param('hdlcoder_led_blinking', 'OptimizationReport', 'on');
hdlset_param('hdlcoder_led_blinking', ...
    'ReferenceDesign', 'Default system (Qsys 14.0)');

```

```

hdlset_param('hdlcoder_led_blinking', 'ResetType', 'Synchronous');
hdlset_param('hdlcoder_led_blinking', 'ResourceReport', 'on');
hdlset_param('hdlcoder_led_blinking', 'SynthesisTool', 'Altera QUARTUS II');
hdlset_param('hdlcoder_led_blinking', 'SynthesisToolChipFamily', 'Cyclone V');
hdlset_param('hdlcoder_led_blinking', 'SynthesisToolDeviceName', '5CSXFC6D6F31C6');
hdlset_param('hdlcoder_led_blinking', 'TargetDirectory', 'hdl_prj\hdlsrc');
hdlset_param('hdlcoder_led_blinking', ...
    'TargetPlatform', 'Altera Cyclone V SoC development kit - Rev.D');
hdlset_param('hdlcoder_led_blinking', 'Traceability', 'on');
hdlset_param('hdlcoder_led_blinking', 'Workflow', 'IP Core Generation');

% Set SubSystem HDL parameters
hdlset_param('hdlcoder_led_blinking/led_counter', ...
    'ProcessorFPGASynchronization', 'Free running');

% Set Inport HDL parameters
hdlset_param('hdlcoder_led_blinking/led_counter/Blink_frequency', ...
    'IOInterface', 'AXI4');
hdlset_param('hdlcoder_led_blinking/led_counter/Blink_frequency', ...
    'IOInterfaceMapping', 'x"100"');

% Set Inport HDL parameters
hdlset_param('hdlcoder_led_blinking/led_counter/Blink_direction', ...
    'IOInterface', 'AXI4');
hdlset_param('hdlcoder_led_blinking/led_counter/Blink_direction', ...
    'IOInterfaceMapping', 'x"104"');

% Set Outputport HDL parameters
hdlset_param('hdlcoder_led_blinking/led_counter/LED', 'IOInterface', 'External Port');

% Set Outputport HDL parameters
hdlset_param('hdlcoder_led_blinking/led_counter/Read_back', 'IOInterface', 'AXI4');
hdlset_param('hdlcoder_led_blinking/led_counter/Read_back', ...
    'IOInterfaceMapping', 'x"108"');

%% Workflow Configuration Settings
% Construct the Workflow Configuration Object with default settings
hWC = hdlcoder.WorkflowConfig('SynthesisTool','Altera QUARTUS II', ...
    'TargetWorkflow','IP Core Generation');

% Specify the top level project directory
hWC.ProjectFolder = 'hdl_prj';

% Set Workflow tasks to run
hWC.RunTaskGenerateRTLCodeAndIPCore = true;
hWC.RunTaskCreateProject = true;
hWC.RunTaskGenerateSoftwareInterfaceModel = false;
hWC.RunTaskBuildFPGABitstream = true;
hWC.RunTaskProgramTargetDevice = false;

% Set Properties related to Generate RTL Code And IP Core Task
hWC.IPCoreRepository = '';
hWC.GenerateIPCoreReport = true;

% Set Properties related to Create Project Task
hWC.Objective = hdlcoder.Objective.AreaOptimized;

```

```

% Set Properties related to Generate Software Interface Model Task
hWC.OperatingSystem = '';
hWC.AddLinuxDeviceDriver = false;

% Set Properties related to Build FPGA Bitstream Task
hWC.RunExternalBuild = true;
hWC.TclFileForSynthesisBuild = hdlcoder.BuildOption.Default;

% Validate the Workflow Configuration Object
hWC.validate;

%% Run the workflow
hdlcoder.runWorkflow('hdlcoder_led_blinking/led_counter', hWC);

```

Optionally, edit the script.

For example, enable or disable tasks in the `hdlcoder.WorkflowConfig` object, `hWC`.

Run the HDL workflow script.

For example, if the script file name is `ip_core_workflow_example.m`, at the command line, enter:

```
ip_core_gen_workflow_example.m
```

Configure and Run Simulink Real-Time FPGA I/O Workflow for ISE-Based Boards with a Script

This example shows how to configure and run an exported HDL workflow script.

To generate an HDL workflow script, configure and run the HDL Workflow Advisor with your Simulink design, then export the script.

This script is a Simulink Real-Time FPGA I/O workflow script that targets the Speedgoat I0331 board that uses the Xilinx ISE synthesis tool.

Open and view your exported HDL workflow script.

```

%-----
% HDL Workflow Script
% Generated with MATLAB 9.5 (R2018b Prerelease) at 18:14:14 on 08/05/2018
% This script was generated using the following parameter values:
%   Filename   : 'C:\Users\ggnanase\Desktop\R2018b\18b_models\ipcore_timing_failure\hdlworkflow
%   Overwrite  : true
%   Comments   : true
%   Headers    : true
%   DUT        : 'sfir_fixed/symmetric_fir'
% To view changes after modifying the workflow, run the following command:
% >> hWC.export('DUT','sfir_fixed/symmetric_fir');
%-----

%% Load the Model
load_system('sfir_fixed');

%% Restore the Model to default HDL parameters
%hdlrestoreparams('sfir_fixed/symmetric_fir');

```

```

%% Model HDL Parameters
%% Set Model 'sfir_fixed' HDL parameters
hdlset_param('sfir_fixed', 'HDLSubsystem', 'sfir_fixed/symmetric_fir');
hdlset_param('sfir_fixed', 'SynthesisTool', 'Xilinx ISE');
hdlset_param('sfir_fixed', 'SynthesisToolChipFamily', 'Spartan6');
hdlset_param('sfir_fixed', 'SynthesisToolDeviceName', 'xc6slx150');
hdlset_param('sfir_fixed', 'SynthesisToolPackageName', 'fgg676');
hdlset_param('sfir_fixed', 'SynthesisToolSpeedValue', '-3');
hdlset_param('sfir_fixed', 'TargetDirectory', 'hdl_prj\hdlsrc');
hdlset_param('sfir_fixed', 'TargetFrequency', 75);
hdlset_param('sfir_fixed', 'TargetPlatform', 'Speedgoat I0331');
hdlset_param('sfir_fixed', 'Workflow', 'Simulink Real-Time FPGA I/O');

%% Workflow Configuration Settings
% Construct the Workflow Configuration Object with default settings
hWC = hdlcoder.WorkflowConfig('SynthesisTool', 'Xilinx ISE', 'TargetWorkflow', 'Simulink Real-Time FPGA I/O');

% Specify the top level project directory
hWC.ProjectFolder = 'hdl_prj';
hWC.ReferenceDesignToolVersion = '';
hWC.IgnoreToolVersionMismatch = false;

% Set Workflow tasks to run
hWC.RunTaskGenerateRTLCode = true;
hWC.RunTaskCreateProject = true;
hWC.RunTaskPerformLogicSynthesis = true;
hWC.RunTaskPerformMapping = true;
hWC.RunTaskPerformPlaceAndRoute = true;
hWC.RunTaskGenerateProgrammingFile = true;
hWC.RunTaskGenerateSimulinkRealTimeInterface = true;

% Set properties related to 'RunTaskCreateProject' Task
hWC.Objective = hdlcoder.Objective.None;
hWC.AdditionalProjectCreationTclFiles = '';

% Set properties related to 'RunTaskPerformMapping' Task
hWC.SkipPreRouteTimingAnalysis = true;

% Set properties related to 'RunTaskPerformPlaceAndRoute' Task
hWC.IgnorePlaceAndRouteErrors = false;

% Validate the Workflow Configuration Object
hWC.validate;

%% Run the workflow
hdlcoder.runWorkflow('sfir_fixed/symmetric_fir', hWC);

```

Optionally, edit the script.

For example, enable or disable tasks in the `hdlcoder.WorkflowConfig` object, `hWC`.

Run the HDL workflow script.

For example, if the script file name is `slrt_workflow_example.m`, at the command line, enter:

```
slrt_workflow_example.m
```

Configure and Run Simulink Real-Time FPGA I/O Workflow for Vivado-Based Boards with a Script

This example shows how to configure and run an exported HDL workflow script.

To generate an HDL workflow script, configure and run the HDL Workflow Advisor with your Simulink design, then export the script.

This script is a Simulink Real-Time FPGA I/O workflow script that targets the Speedgoat I0333-325K board that uses the Xilinx Vivado synthesis tool.

Open and view your exported HDL workflow script.

```

%-----
% HDL Workflow Script
% Generated with MATLAB 9.5 (R2018b Prerelease) at 18:14:33 on 08/05/2018
% This script was generated using the following parameter values:
%   Filename   : 'C:\Users\ggnanase\Desktop\R2018b\18b_models\ipcore_timing_failure\hdlworkflow
%   Overwrite  : true
%   Comments   : true
%   Headers    : true
%   DUT        : 'sfir_fixed/symmetric_fir'
% To view changes after modifying the workflow, run the following command:
% >> hWC.export('DUT','sfir_fixed/symmetric_fir');
%-----

%% Load the Model
load_system('sfir_fixed');

%% Restore the Model to default HDL parameters
%hdlrestoreparams('sfir_fixed/symmetric_fir');

%% Model HDL Parameters
%% Set Model 'sfir_fixed' HDL parameters
hdlset_param('sfir_fixed', 'HDLSubsystem', 'sfir_fixed/symmetric_fir');
hdlset_param('sfir_fixed', 'SynthesisTool', 'Xilinx Vivado');
hdlset_param('sfir_fixed', 'SynthesisToolChipFamily', 'Kintex7');
hdlset_param('sfir_fixed', 'SynthesisToolDeviceName', 'xc7k325t');
hdlset_param('sfir_fixed', 'SynthesisToolPackageName', 'ffg900');
hdlset_param('sfir_fixed', 'SynthesisToolSpeedValue', '-2');
hdlset_param('sfir_fixed', 'TargetDirectory', 'hdl_prj\hdlsrc');
hdlset_param('sfir_fixed', 'TargetFrequency', 100);
hdlset_param('sfir_fixed', 'TargetPlatform', 'Speedgoat I0333-325K');
hdlset_param('sfir_fixed', 'Workflow', 'Simulink Real-Time FPGA I/O');

%% Workflow Configuration Settings
% Construct the Workflow Configuration Object with default settings
hWC = hldcoder.WorkflowConfig('SynthesisTool','Xilinx Vivado','TargetWorkflow','Simulink Real-Ti

% Specify the top level project directory
hWC.ProjectFolder = 'hdl_prj';
hWC.ReferenceDesignToolVersion = '2017.4';
hWC.IgnoreToolVersionMismatch = false;

% Set Workflow tasks to run
hWC.RunTaskGenerateRTLCodeAndIPCore = true;
hWC.RunTaskCreateProject = true;

```

```
hWC.RunTaskBuildFPGABitstream = true;
hWC.RunTaskGenerateSimulinkRealTimeInterface = true;

% Set properties related to 'RunTaskGenerateRTLCodeAndIPCore' Task
hWC.IPCoreRepository = '';
hWC.GenerateIPCoreReport = true;
hWC.GenerateIPCoreTestbench = false;
hWC.CustomIPTopHDLFile = '';
hWC.AXI4RegisterReadback = false;
hWC.IPDataCaptureBufferSize = '128';

% Set properties related to 'RunTaskCreateProject' Task
hWC.Objective = hdlcoder.Objective.None;
hWC.AdditionalProjectCreationTclFiles = '';
hWC.EnableIPCaching = true;

% Set properties related to 'RunTaskBuildFPGABitstream' Task
hWC.RunExternalBuild = false;
hWC.TclFileForSynthesisBuild = hdlcoder.BuildOption.Default;
hWC.CustomBuildTclFile = '';
hWC.ReportTimingFailure = hdlcoder.ReportTiming.Error;

% Validate the Workflow Configuration Object
hWC.validate;

%% Run the workflow
hdlcoder.runWorkflow('sfir_fixed/symmetric_fir', hWC);
```

Optionally, edit the script.

For example, enable or disable tasks in the `hdlcoder.WorkflowConfig` object, `hWC`.

Run the HDL workflow script.

For example, if the script file name is `slrt_workflow_example.m`, at the command line, enter:

```
slrt_workflow_example.m
```

See Also

Functions

`hdlcoder.runWorkflow`

Topics

“Run HDL Workflow with a Script”

Introduced in R2015b

export

Class: hdlcoder.WorkflowConfig

Package: hdlcoder

Generate MATLAB script that recreates the workflow configuration

Syntax

export(Name,Value)

Description

export(Name,Value) generates MATLAB commands that can recreate the current workflow configuration, with additional options specified by one or more Name,Value pair arguments.

Name-Value Pair Arguments

Specify optional comma-separated pairs of Name,Value arguments. Name is the argument name and Value is the corresponding value. Name must appear inside quotes. You can specify several name and value pair arguments in any order as Name1,Value1,...,NameN,ValueN.

Filename — Full path to exported script file

' ' (default) | character vector

Full path to the exported MATLAB script file, specified as a character vector. If the path is empty, the MATLAB commands are displayed in the Command Window, but not saved in a file.

Example: 'L:\sandbox\work\hdlworkflow.m'

Overwrite — Overwrite existing file

false (default) | true

Specify whether to overwrite the existing file as a logical.

Comments — Include comments

true (default) | false

Specify whether to include comments in the command list or script as a logical.

Headers — Include headers

true (default) | false

Specify whether to include a header in the command list or script as a logical.

DUT — Full path to DUT

' ' (default) | character vector

Full path to the DUT, specified as a character vector.

Example: 'hdlcoder_led_blinking/led_counter'

See Also

Classes

`hdlcoder.WorkflowConfig`

Topics

“Run HDL Workflow with a Script”

Introduced in R2015b

setAllTasks

Class: hdlcoder.WorkflowConfig

Package: hdlcoder

Enable all tasks in workflow

Syntax

```
setAllTasks
```

Description

setAllTasks enables all workflow tasks in the hdlcoder.WorkflowConfig object.

If you do not want to enable each task individually, use this method. For example, if you want to run all tasks but one, you can run `hdlcoder.WorkflowConfig.setAllTasks`, then disable the task that you want to skip.

See Also

Functions

`clearAllTasks`

Classes

`hdlcoder.WorkflowConfig`

Topics

“Run HDL Workflow with a Script”

Introduced in R2015b

clearAllTasks

Class: hdlcoder.WorkflowConfig

Package: hdlcoder

Disable all tasks in workflow

Syntax

```
clearAllTasks
```

Description

clearAllTasks disables all workflow tasks in the hdlcoder.WorkflowConfig object.

If you do not want to disable each task individually, use this method. For example, if you want to run a single task, you can run hdlcoder.WorkflowConfig.clearAllTasks, then enable the task that you want to run.

See Also

Functions

setAllTasks

Classes

hdlcoder.WorkflowConfig

Topics

“Run HDL Workflow with a Script”

Introduced in R2015b

validate

Class: hdlcoder.WorkflowConfig

Package: hdlcoder

Check property values in HDL Workflow CLI configuration object

Syntax

```
validate
```

Description

`validate` verifies that the `hdlcoder.WorkflowConfig` object has acceptable values for all required properties, and that property values have valid data types. If validation fails, you get an error message.

See Also

`hdlcoder.WorkflowConfig`

Topics

“Run HDL Workflow with a Script”

Introduced in R2015b

hdlcoder.runWorkflow

Run HDL code generation and deployment workflow

Syntax

```
hdlcoder.runWorkflow(DUT)
hdlcoder.runWorkflow(DUT,workflow_config)
hdlcoder.runWorkflow(DUT,workflow_config, Verbosity)
```

Description

`hdlcoder.runWorkflow(DUT)` runs the HDL code generation and deployment workflow with default workflow configuration settings.

`hdlcoder.runWorkflow(DUT,workflow_config)` runs the HDL code generation and deployment workflow according to the specified workflow configuration, `workflow_config`.

A best practice is to use the HDL Workflow Advisor to configure the workflow, then export a workflow script. The commands in the workflow script create and configure a workflow configuration object that matches the settings in the HDL Workflow Advisor. The script includes the `hdlcoder.runWorkflow` command. To learn more, see “Run HDL Workflow with a Script”.

`hdlcoder.runWorkflow(DUT,workflow_config, Verbosity)` runs the HDL code generation and deployment workflow according to the specified workflow configuration, `workflow_config`, and the level of detail for progress messages generated as the workflow proceeds.

A best practice is to use the HDL Workflow Advisor to configure the workflow, then export a workflow script. The commands in the workflow script create and configure a workflow configuration object that matches the settings in the HDL Workflow Advisor. The script includes the `hdlcoder.runWorkflow` command. To learn more, see “Run HDL Workflow with a Script”.

Examples

Run Workflow with Configuration Object

This example is a generic ASIC/FPGA workflow script that targets a Xilinx Virtex-7 device. It uses the Xilinx Vivado synthesis tool. The example generates HDL code for the `sfir_fixed` model, and performs FPGA synthesis and analysis.

Before running the Workflow

Before running the workflow, you must have the synthesis tool installed. Use `hdlsetuptoolpath` to specify the path to your synthesis tool.

```
hdlsetuptoolpath('ToolName','Xilinx Vivado','ToolPath',...
'L:\Xilinx\Vivado\2016.2\bin\vivado.bat');
```

Prepending following Xilinx Vivado path(s) to the system path:
L:\Xilinx\Vivado\2016.2\bin

Specify the model for running the workflow

To run the HDL workflow with default settings for a DUT subsystem, modelname/DUT, at the command line, enter:

```
open_system('sfir_fixed');
```

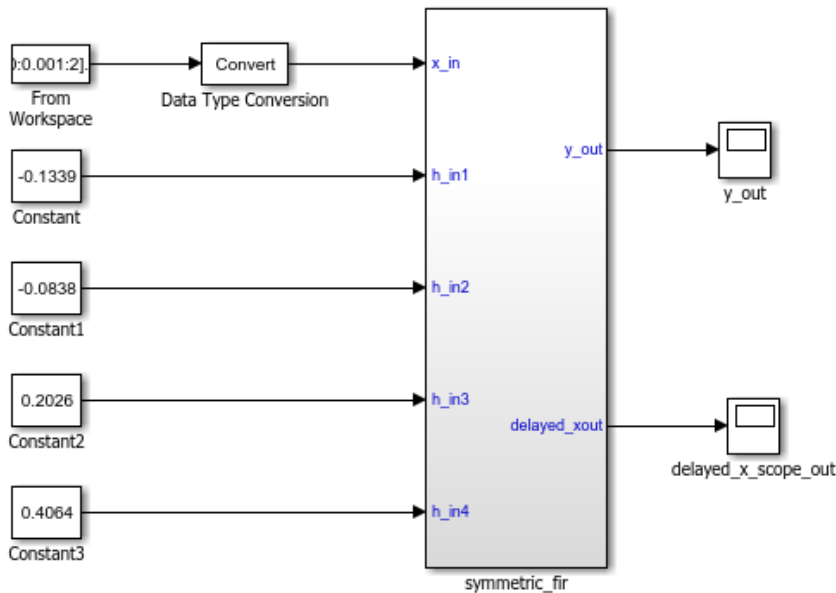

This example shows how to use HDL Coder to check, generate, and verify HDL for a fixed-point symmetric FIR filter. In MATLAB, type the following:

```
checkhdl('sfir_fixed/symmetric_fir')
makehdl('sfir_fixed/symmetric_fir')
makehdltb('sfir_fixed/symmetric_fir')
```

Or double-click the blue button at the bottom to see the dialog.

Launch HDL Dialog

Run Demo

Copyright 2007 The MathWorks, Inc.

Model HDL Parameters

Set Model HDL parameters

```
hdlset_param('sfir_fixed', 'SynthesisTool', 'Xilinx Vivado');
hdlset_param('sfir_fixed', 'SynthesisToolChipFamily', 'Virtex7');
hdlset_param('sfir_fixed', 'SynthesisToolDeviceName', 'xc7vx485t');
hdlset_param('sfir_fixed', 'SynthesisToolPackageName', 'ffgl761');
hdlset_param('sfir_fixed', 'SynthesisToolSpeedValue', '-2');
```

Workflow Configuration Settings

- Construct the Workflow Configuration Object with default settings
- Specify the path to your project folder. This step is optional

```
hWC = hdlcoder.WorkflowConfig('SynthesisTool','Xilinx Vivado', ...
    'TargetWorkflow','Generic ASIC/FPGA');
```

```
hWC.ProjectFolder = 'C:/Temp/hdl_prj';
```

Run the workflow

```
hdlcoder.runWorkflow('sfir_fixed/symmetric_fir', hWC);

### Workflow begin.
### Loading settings from model.
### ++++++ Task Generate RTL Code and Testbench ++++++
### Generating HDL for 'sfir_fixed/symmetric_fir'.
### Starting HDL check.
### Begin VHDL Code Generation for 'sfir_fixed'.
### Working on sfir_fixed/symmetric_fir as C:\Temp\hdl_prj\hdlsrc\sfir_fixed\symmetric_fir.vhd.
### Creating HDL Code Generation Check Report file://C:\Temp\hdl_prj\hdlsrc\sfir_fixed\symmetric_fir\hdl_codegen_check_report.html
### HDL check for 'sfir_fixed' complete with 0 errors, 0 warnings, and 0 messages.
### HDL code generation complete.
### ++++++ Task Create Project ++++++
### Generating Xilinx Vivado 2016.2 project: <a href="matlab:downstream.tool.openTargetTool('L:\Temp\hdl_prj\hdlsrc\sfir_fixed\work\sfir_fixed.vivado')">here</a>
### Generated logfile: <a href="matlab:edit('C:\Temp\hdl_prj\hdlsrc\sfir_fixed\work\sfir_fixed.vivado\log.txt')">here</a>
### Task "Create Project" successful.
### ++++++ Task Run Synthesis ++++++
### Generated logfile: <a href="matlab:edit('C:\Temp\hdl_prj\hdlsrc\sfir_fixed\work\sfir_fixed.vivado\log.txt')">here</a>
### Task "Run Synthesis" successful.
### ++++++ Task Annotate Model with Synthesis Result ++++++
### Parsing the timing file...
### Matched Source = 'sfir_fixed/symmetric_fir/udl_out1'
### Matched Destination = 'sfir_fixed/symmetric_fir/y_out'
### Highlighting CP 1 from 'sfir_fixed/symmetric_fir/udl_out1' to 'sfir_fixed/symmetric_fir/y_out'
### Click <a href="matlab:hdlannotatpath('reset')">here</a> to reset highlighting.
### Workflow complete.
```

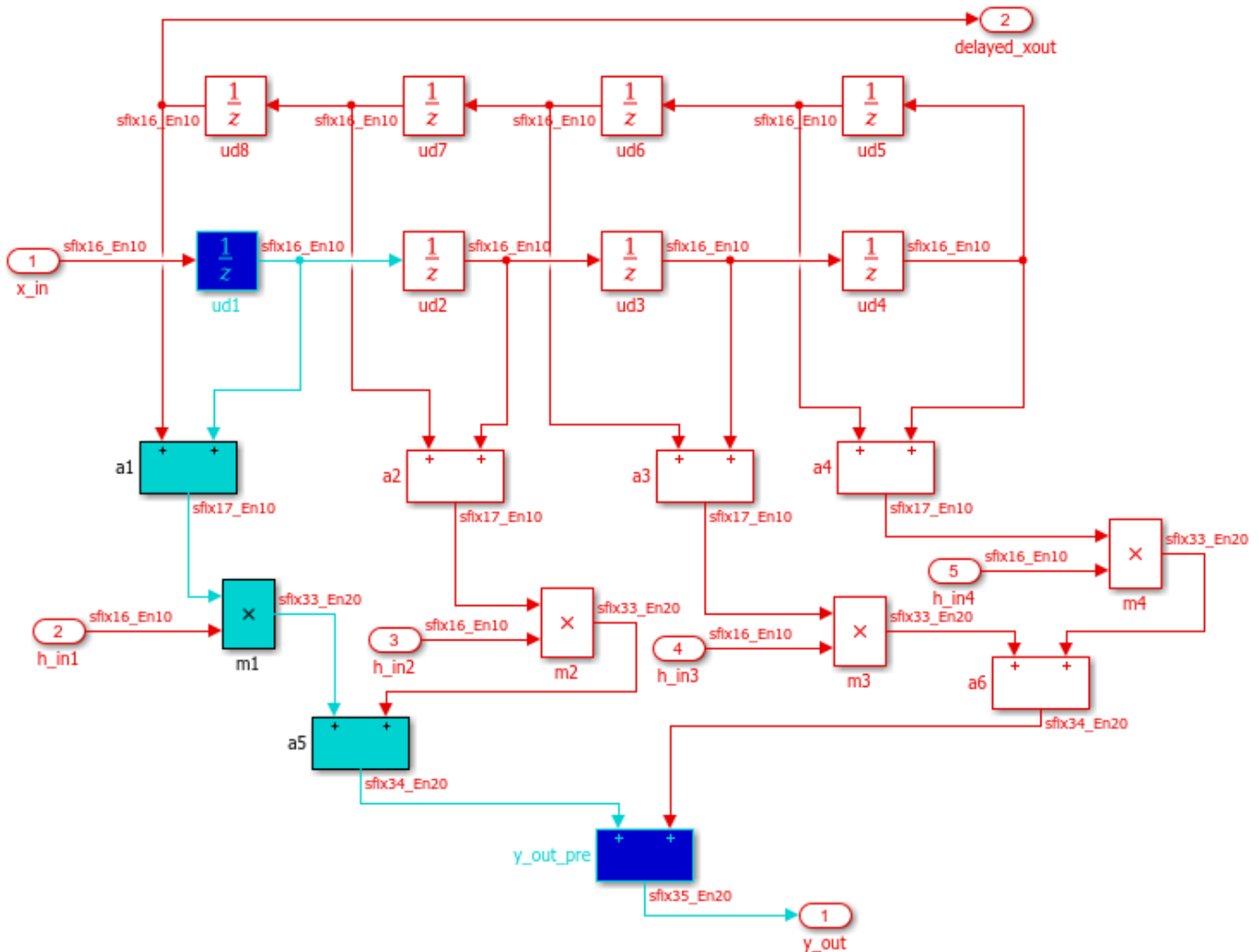
Input Arguments

DUT – Full path to DUT

' ' (default) | character vector

Full path to the DUT, specified as a character vector.

Example: 'hdlcoder_led_blinking/led_counter'

workflow_config – Workflow configuration

hdlcoder.WorkflowConfig

HDL code generation and deployment workflow configuration, specified as an hdlcoder.WorkflowConfig object.

Verbosity – Level of detail

'off' (default) | 'on'

When `Verbosity` is left to default value of `'off'`, minimal code generation progress messages are displayed as the code generation and deployment workflow runs. When `Verbosity` is set to `'on'`, more detailed progress messages are displayed.

See Also

Functions

`clearAllTasks` | `setAllTasks`

Classes

`hdlcoder.WorkflowConfig`

Topics

“Run HDL Workflow with a Script”

Introduced in R2015b

hdlcoder.OptimizationConfig class

Package: hdlcoder

hdlcoder.optimizeDesign configuration object

Description

Use the hdlcoder.OptimizationConfig object to set options for the hdlcoder.optimizeDesign function.

Maximum Clock Frequency Configuration

To configure hdlcoder.optimizeDesign to maximize the clock frequency of your design:

- Set ExplorationMode to hdlcoder.OptimizationConfig.ExplorationMode.BestFrequency.
- Set ResumptionPoint to the default, ''.

You can optionally set IterationLimit and TestbenchGeneration to nondefault values. HDL Coder ignores the TargetFrequency setting.

Target Clock Frequency Configuration

To configure hdlcoder.optimizeDesign to meet a target clock frequency:

- Set ExplorationMode to hdlcoder.OptimizationConfig.ExplorationMode.TargetFrequency.
- Set TargetFrequency to your target clock frequency.
- Set ResumptionPoint to the default, ''.

You can optionally set IterationLimit and TestbenchGeneration to nondefault values.

Resume From Interruption Configuration

To configure hdlcoder.optimizeDesign to resume after an interruption, specify ResumptionPoint.

When you set ResumptionPoint to a nondefault value, the other properties are ignored.

Construction

`optimcfg = hdlcoder.OptimizationConfig` creates an hdlcoder.OptimizationConfig object for automatic iterative HDL design optimization.

Properties

ExplorationMode — Optimization target mode

hdlcoder.OptimizationConfig.ExplorationMode.BestFrequency (default) |
hdlcoder.OptimizationConfig.ExplorationMode.TargetFrequency

Optimization target mode, specified as one of these values:

<code>hdlcoder.OptimizationConfig.ExplorationMode.BestFrequency</code>	Optimizes the design to try to achieve the maximum clock frequency
<code>hdlcoder.OptimizationConfig.ExplorationMode.TargetFrequency</code>	Optimizes the design to try to achieve the specified target clock frequency

`hdlcoder.OptimizationConfig.ExplorationMode.BestFrequency` is the default.

IterationLimit — Maximum number of iterations

1 (default) | positive integer

Maximum number of optimization iterations before exiting, specified as a positive integer.

If `ExplorationMode` is `hdlcoder.OptimizationConfig.ExplorationMode.BestFrequency`, HDL Coder runs this number of iterations.

If `ExplorationMode` is `hdlcoder.OptimizationConfig.ExplorationMode.TargetFrequency`, HDL Coder runs the number of iterations needed to meet the target frequency. Otherwise, the coder runs the maximum number of iterations.

ResumptionPoint — Folder containing optimization data from earlier iteration

' ' (default) | character vector

Name of folder that contains previously-generated optimization iteration data, specified as a character vector. The folder is a subfolder of `hdlexpl`, and the folder name begins with the character vector, `Iter`.

When you set `ResumptionPoint` to a nondefault value, `hdlcoder.optimizeDesign` ignores the other configuration object properties.

Example: `'Iter1-26-Sep-2013-10-19-13'`

TargetFrequency — Target clock frequency

Inf (default) | double

Target clock frequency, specified as a double in MHz. Specify when `ExplorationMode` is `hdlcoder.OptimizationConfig.ExplorationMode.TargetFrequency`.

Examples

Configure `hdlcoder.optimizeDesign` for maximum clock frequency

Open the model and specify the DUT subsystem.

```
model = 'sfir_fixed';
dutSubsys = 'symmetric_fir';
open_system(model);
hdlset_param(model, 'HDLSubsystem', [model, '/', dutSubsys]);
```

Set your synthesis tool and target device options.

```
hdlset_param(model, 'SynthesisTool', 'Xilinx ISE', ...
                'SynthesisToolChipFamily', 'Zynq', ...
                'SynthesisToolDeviceName', 'xc7z030', ...
                'SynthesisToolPackageName', 'fbg484', ...
                'SynthesisToolSpeedValue', '-3')
```

Enable HDL test bench generation.

```
hdlset_param(model, 'GenerateHDLTestBench', 'on');
```

Save your model.

You must save your model if you want to regenerate code later without rerunning the iterative optimizations, or resume your run if it is interrupted. When you use `hdlcoder.optimizeDesign` to regenerate code or resume an interrupted run, HDL Coder checks the model checksum and generates an error if the model has changed.

Create an optimization configuration object, `oc`.

```
oc = hdlcoder.OptimizationConfig;
```

Set the iteration limit to 10.

```
oc.IterationLimit = 10;
```

Optimize the model.

```
hdlcoder.optimizeDesign(model, oc)
```

```
hdlset_param('sfir_fixed', 'HDLSubsystem', 'sfir_fixed/symmetric_fir');
hdlset_param('sfir_fixed', 'SynthesisTool', 'Xilinx ISE');
hdlset_param('sfir_fixed', 'SynthesisToolChipFamily', 'Zynq');
hdlset_param('sfir_fixed', 'SynthesisToolDeviceName', 'xc7z030');
hdlset_param('sfir_fixed', 'SynthesisToolPackageName', 'fbg484');
hdlset_param('sfir_fixed', 'SynthesisToolSpeedValue', '-3');
```

Iteration 0

```
Generate and synthesize HDL code ...
(CP ns) 16.26 (Constraint ns) 5.85 (Elapsed s) 143.66 Iteration 1
Generate and synthesize HDL code ...
(CP ns) 16.26 (Constraint ns) 5.85 (Elapsed s) 278.72 Iteration 2
Generate and synthesize HDL code ...
(CP ns) 10.25 (Constraint ns) 12.73 (Elapsed s) 427.22 Iteration 3
Generate and synthesize HDL code ...
(CP ns) 9.55 (Constraint ns) 9.73 (Elapsed s) 584.37 Iteration 4
Generate and synthesize HDL code ...
(CP ns) 9.55 (Constraint ns) 9.38 (Elapsed s) 741.04 Iteration 5
Generate and synthesize HDL code ...
Exiting because critical path cannot be further improved.
```

Summary report: summary.html

```
Achieved Critical Path (CP) Latency : 9.55 ns Elapsed : 741.04 s
Iteration 0: (CP ns) 16.26 (Constraint ns) 5.85 (Elapsed s) 143.66
Iteration 1: (CP ns) 16.26 (Constraint ns) 5.85 (Elapsed s) 278.72
Iteration 2: (CP ns) 10.25 (Constraint ns) 12.73 (Elapsed s) 427.22
Iteration 3: (CP ns) 9.55 (Constraint ns) 9.73 (Elapsed s) 584.37
Iteration 4: (CP ns) 9.55 (Constraint ns) 9.38 (Elapsed s) 741.04
```

Final results are saved in

```
/tmp/hdlsrsrc/sfir_fixed/hdlexpl/Final-07-Jan-2014-17-04-41
```

Validation model: gm_sfir_fixed_vnl

Then HDL Coder stops after five iterations because the fourth and fifth iterations had the same critical path, which indicates that the coder has found the minimum critical path. The design's maximum clock frequency after optimization is 1 / 9.55 ns, or 104.71 MHz.

Configure `hdlcoder.optimizeDesign` for target clock frequency

Open the model and specify the DUT subsystem.

```
model = 'sfir_fixed';
dutSubsys = 'symmetric_fir';
open_system(model);
hdlset_param(model, 'HDLSubsystem', [model, '/', dutSubsys]);
```

Set your synthesis tool and target device options.

```
hdlset_param(model, 'SynthesisTool', 'Xilinx ISE', ...
                  'SynthesisToolChipFamily', 'Zynq', ...
                  'SynthesisToolDeviceName', 'xc7z030', ...
                  'SynthesisToolPackageName', 'fbg484', ...
                  'SynthesisToolSpeedValue', '-3')
```

Disable HDL test bench generation.

```
hdlset_param(model, 'GenerateHDLTestBench', 'off');
```

Save your model.

You must save your model if you want to regenerate code later without rerunning the iterative optimizations, or resume your run if it is interrupted. When you use `hdlcoder.optimizeDesign` to regenerate code or resume an interrupted run, HDL Coder checks the model checksum and generates an error if the model has changed.

Create an optimization configuration object, `oc`.

```
oc = hdlcoder.OptimizationConfig;
```

Configure the automatic iterative optimization to stop after it reaches a clock frequency of 50MHz, or 10 iterations, whichever comes first.

```
oc.ExplorationMode = ...
    hdlcoder.OptimizationConfig.ExplorationMode.TargetFrequency;
oc.TargetFrequency = 50;
oc.IterationLimit = 10; =
```

Optimize the model.

```
hdlcoder.optimizeDesign(model, oc)

hdlset_param('sfir_fixed', 'GenerateHDLTestBench', 'off');
hdlset_param('sfir_fixed', 'HDLSubsystem', 'sfir_fixed/symmetric_fir');
hdlset_param('sfir_fixed', 'SynthesisTool', 'Xilinx ISE');
hdlset_param('sfir_fixed', 'SynthesisToolChipFamily', 'Zynq');
hdlset_param('sfir_fixed', 'SynthesisToolDeviceName', 'xc7z030');
hdlset_param('sfir_fixed', 'SynthesisToolPackageName', 'fbg484');
hdlset_param('sfir_fixed', 'SynthesisToolSpeedValue', '-3');
```

```

Iteration 0
Generate and synthesize HDL code ...
(CP ns) 16.26      (Constraint ns) 20.00      (Elapsed s) 134.02 Iteration 1
Generate and synthesize HDL code ...
Exiting because constraint (20.00 ns) has been met (16.26 ns).
Summary report: summary.html
Achieved Critical Path (CP) Latency : 16.26 ns      Elapsed : 134.02 s
Iteration 0: (CP ns) 16.26      (Constraint ns) 20.00      (Elapsed s) 134.02
Final results are saved in
    /tmp/hdlsrc/sfir_fixed/hdlexpl/Final-07-Jan-2014-17-07-14
Validation model: gm_sfir_fixed_vnl

```

Then HDL Coder stops after one iteration because it has achieved the target clock frequency. The critical path is 16.26 ns, a clock frequency of 61.50 GHz.

Configure `hdlcoder.optimizeDesign` to resume from interruption

Open the model and specify the DUT subsystem.

```

model = 'sfir_fixed';
dutSubsys = 'symmetric_fir';
open_system(model);
hdlset_param(model, 'HDLSubsystem', [model, '/', dutSubsys]);

```

Set your synthesis tool and target device options to the same values as in the interrupted run.

```

hdlset_param(model, 'SynthesisTool', 'Xilinx ISE', ...
    'SynthesisToolChipFamily', 'Zynq', ...
    'SynthesisToolDeviceName', 'xc7z030', ...
    'SynthesisToolPackageName', 'fbg484', ...
    'SynthesisToolSpeedValue', '-3')

```

Enable HDL test bench generation.

```
hdlset_param(model, 'GenerateHDLTestBench', 'on');
```

Create an optimization configuration object, `oc`.

```
oc = hdlcoder.OptimizationConfig;
```

Configure the automatic iterative optimization to run using data from the first iteration of a previous run.

```
oc.ResumptionPoint = 'Iter5-07-Jan-2014-17-04-29';
```

Optimize the model.

```
hdlcoder.optimizeDesign(model, oc)
```

```
hdlset_param('sfir_fixed', 'HDLSubsystem', 'sfir_fixed/symmetric_fir');
hdlset_param('sfir_fixed', 'SynthesisTool', 'Xilinx ISE');
hdlset_param('sfir_fixed', 'SynthesisToolChipFamily', 'Zynq');
hdlset_param('sfir_fixed', 'SynthesisToolDeviceName', 'xc7z030');
hdlset_param('sfir_fixed', 'SynthesisToolPackageName', 'fbg484');
hdlset_param('sfir_fixed', 'SynthesisToolSpeedValue', '-3');

```

Try to resume from resumption point: Iter5-07-Jan-2014-17-04-29

```
Iteration 5
Generate and synthesize HDL code ...
Exiting because critical path cannot be further improved.
Summary report: summary.html
Achieved Critical Path (CP) Latency : 9.55 ns      Elapsed : 741.04 s
Iteration 0: (CP ns) 16.26    (Constraint ns) 5.85    (Elapsed s) 143.66
Iteration 1: (CP ns) 16.26    (Constraint ns) 5.85    (Elapsed s) 278.72
Iteration 2: (CP ns) 10.25    (Constraint ns) 12.73   (Elapsed s) 427.22
Iteration 3: (CP ns) 9.55     (Constraint ns) 9.73    (Elapsed s) 584.37
Iteration 4: (CP ns) 9.55     (Constraint ns) 9.38    (Elapsed s) 741.04
Final results are saved in
    /tmp/hdlsrc/sfir_fixed/hdlexpl/Final-07-Jan-2014-17-07-30
Validation model: gm_sfir_fixed_vnl
```

Then coder stops after one additional iteration because it has achieved the target clock frequency. The critical path is 9.55 ns, or a clock frequency of 104.71 MHz.

See Also

`hdlcoder.optimizeDesign`

Functions for HDL Code Generation from MATLAB

codegen

Generate HDL code from MATLAB code

Syntax

```
codegen -confighdlcfg matlab_design_name  
codegen -confighdlcfg -float2fixed fixptcfg matlab_design_name
```

Description

`codegen -confighdlcfg matlab_design_name` generates HDL code from MATLAB code.

`codegen -confighdlcfg -float2fixed fixptcfg matlab_design_name` converts floating-point MATLAB code to fixed-point code, then generates HDL code.

Examples

Generate Verilog Code from MATLAB Code

Create a `coder.HdlConfig` object, `hdlcfg`.

```
hdlcfg = coder.config('hdl'); % Create a default 'hdl' config
```

Set the test bench name. In this example, the test bench function name is `mlhdlc_dti_tb`.

```
hdlcfg.TestBenchName = 'mlhdlc_dti_tb';
```

Set the target language to Verilog.

```
hdlcfg.TargetLanguage = 'Verilog';
```

Generate HDL code from your MATLAB design. In this example, the MATLAB design function name is `mlhdlc_dti`.

```
codegen -confighdlcfg mlhdlc_dti
```

Generate HDL Code from Floating-Point MATLAB Code

Create a `coder.FixptConfig` object, `fixptcfg`, with default settings.

```
fixptcfg = coder.config('fixpt');
```

Set the test bench name. In this example, the test bench function name is `mlhdlc_dti_tb`.

```
fixptcfg.TestBenchName = 'mlhdlc_dti_tb';
```

Create a `coder.HdlConfig` object, `hdlcfg`, with default settings.

```
hdlcfg = coder.config('hdl');
```

Convert your floating-point MATLAB design to fixed-point, and generate HDL code. In this example, the MATLAB design function name is `mlhdlc_dti`.

```
codegen -float2fixed fixptcfg -config hdlcfg mlhdlc_dti
```

Input Arguments

hdlcfg — HDL code generation configuration

`coder.HdlConfig`

HDL code generation configuration options, specified as a `coder.HdlConfig` object.

Create a `coder.HdlConfig` object using the HDL `coder.config` function.

matlab_design_name — MATLAB design function name

character vector

Name of top-level MATLAB function for which you want to generate HDL code.

fixptcfg — Floating-point to fixed-point conversion configuration

`coder.FixptConfig`

Floating-point to fixed-point conversion configuration options, specified as a `coder.FixptConfig` object.

Use `fixptcfg` when generating HDL code from floating-point MATLAB code. Create a `coder.FixptConfig` object using the HDL `coder.config` function.

See Also

`coder.FixptConfig` | `coder.HdlConfig` | `coder.config`

Topics

“Generate HDL Code from MATLAB Code Using the Command Line Interface”

Introduced in R2013a

coder.approximation

Create function replacement configuration object

Syntax

```
q = coder.approximation(function_name)
q = coder.approximation('Function',function_name,Name,Value)
```

Description

`q = coder.approximation(function_name)` creates a function replacement configuration object for use during code generation or fixed-point conversion. The configuration object specifies how to create a lookup table approximation for the MATLAB function specified by `function_name`. To associate this approximation with a `coder.FixptConfig` object for use with the `codegen` function, use the `coder.FixptConfig` configuration object `addApproximation` method.

Use this syntax only for the functions that `coder.approximation` can replace automatically. These functions are listed in the `function_name` argument description.

`q = coder.approximation('Function',function_name,Name,Value)` creates a function replacement configuration object using additional options specified by one or more name-value pair arguments.

Examples

Replace Log Function with Default Lookup Table

Create a function replacement configuration object using the default settings. The resulting lookup table in the generated code uses 1000 points.

```
logAppx = coder.approximation('log');
```

Replace Log Function with Uniform Lookup Table

Create a function replacement configuration object. Specify the input range and prefix to add to the replacement function name. The resulting lookup table in the generated code uses 1000 points.

```
logAppx = coder.approximation('Function','log','InputRange',[0.1,1000],...
'FunctionNamePrefix','log_replace');
```

Replace Log Function with Optimized Lookup Table

Create a function replacement configuration object using the `'OptimizeLUTSize'` option to specify to replace the `log` function with an optimized lookup table. The resulting lookup table in the generated code uses less than the default number of points.

```
logAppx = coder.approximation('Function','log','OptimizeLUTSize', true,...
'InputRange',[0.1,1000],'InterpolationDegree',1,'ErrorThreshold',1e-3,...
'FunctionNamePrefix','log_optim_', 'OptimizeIterations',25);
```

Replace Custom Function with Optimized Lookup Table

Create a function replacement configuration object that specifies to replace the custom function, `saturateExp`, with an optimized lookup table.

Create a custom function, `saturateExp`.

```
saturateExp = @(x) 1/(1+exp(-x));
```

Create a function replacement configuration object that specifies to replace the `saturateExp` function with an optimized lookup table. Because the `saturateExp` function is not listed as a function for which `coder.approximation` can generate an approximation automatically, you must specify the `CandidateFunction` property.

```
saturateExp = @(x) 1/(1+exp(-x));
custAppx = coder.approximation('Function','saturateExp',...
'CandidateFunction', saturateExp,...
'NumberOfPoints',50,'InputRange',[0,10]);
```

Input Arguments

function_name — Name of the function to replace

```
'acos' | 'acosd' | 'acosh' | 'acoth' | 'asin' | 'asind' | 'asinh' | 'atan' | 'atand' |
'atanh' | 'cos' | 'cosd' | 'cosh' | 'erf' | 'erfc' | 'exp' | 'log' | 'normcdf' | 'reallog'
| 'realsqrt' | 'reciprocal' | 'rsqrt' | 'sin' | 'sinc' | 'sind' | 'sinh' | 'sqrt' | 'tan' |
'tand'
```

Name of function to replace, specified as a string. The function must be one of the listed functions.

Example: 'sqrt'

Data Types: char

Name-Value Pair Arguments

Specify optional comma-separated pairs of `Name`, `Value` arguments. `Name` is the argument name and `Value` is the corresponding value. `Name` must appear inside quotes. You can specify several name and value pair arguments in any order as `Name1, Value1, ..., NameN, ValueN`.

Example: 'Function', 'log'

Architecture — Architecture of lookup table approximation

```
'LookupTable' (default) | 'Flat'
```

Architecture of the lookup table approximation, specified as the comma-separated pair consisting of 'Architecture' and a string. Use this argument when you want to specify the architecture for the lookup table. The `Flat` architecture does not use interpolation.

Data Types: char

CandidateFunction — Function handle of the replacement function

function handle | string

Function handle of the replacement function, specified as the comma-separated pair consisting of 'CandidateFunction' and a function handle or string referring to a function handle. Use this argument when the function that you want to replace is not listed under `function_name`. Specify the function handle or string referring to a function handle of the function that you want to replace. You can define the function in a file or as an anonymous function.

If you do not specify a candidate function, then the function you chose to replace using the `Function` property is set as the `CandidateFunction`.

Example: 'CandidateFunction', @(x) (1./(1+x))

Data Types: `function_handle` | `char`

ErrorThreshold — Error threshold value used to calculate optimal lookup table size

0.001 (default) | nonnegative scalar

Error threshold value used to calculate optimal lookup table size, specified as the comma-separated pair consisting of 'ErrorThreshold' and a nonnegative scalar. If 'OptimizeLUTSize' is true, this argument is required.

Function — Name of function to replace with a lookup table approximation

function_name

Name of function to replace with a lookup table approximation, specified as the comma-separated pair consisting of 'Function' and a string. The function must be continuous and stateless. If you specify one of the functions that is listed under `function_name`, the conversion process automatically provides a replacement function. Otherwise, you must also specify the 'CandidateFunction' argument for the function that you want to replace.

Example: 'Function','log'

Example: 'Function','my_log','CandidateFunction',@my_log

Data Types: `char`

FunctionNamePrefix — Prefix for generated fixed-point function names

'replacement_' (default) | string

Prefix for generated fixed-point function names, specified as the comma-separated pair consisting of 'FunctionNamePrefix' and a string. The name of a generated function consists of this prefix, followed by the original MATLAB function name.

Example: 'log_replace_'

InputRange — Range over which to replace the function

[] (default) | 2x1 row vector | 2xN matrix

Range over which to replace the function, specified as the comma-separated pair consisting of 'InputRange' and a 2-by-1 row vector or a 2-by-N matrix.

Example: [-1 1]

InterpolationDegree — Interpolation degree

1 (default) | 0 | 2 | 3

Interpolation degree, specified as the comma-separated pair consisting of 'InterpolationDegree' and 1 (linear), 0 (none), 2 (quadratic), or 3 (cubic).

NumberOfPoints — Number of points in lookup table

1000 (default) | positive integer

Number of points in lookup table, specified as the comma-separated pair consisting of 'NumberOfPoints' and a positive integer.

OptimizeIterations — Number of iterations

25 (default) | positive integer

Number of iterations to run when optimizing the size of the lookup table, specified as the comma-separated pair consisting of 'OptimizeIterations' and a positive integer.

OptimizeLUTSize — Optimize lookup table size

false (default) | true

Optimize lookup table size, specified as the comma-separated pair consisting of 'OptimizeLUTSize' and a logical value. Setting this property to true generates an area-optimal lookup table, that is, the lookup table with the minimum possible number of points. This lookup table is optimized for size, but might not be speed efficient.

PipelinedArchitecture — Option to enable pipelining

false (default) | true

Option to enable pipelining, specified as the comma-separated pair consisting of 'PipelinedArchitecture' and a logical value.

Output Arguments

q — Function replacement configuration object, returned as a `coder.mathfcngenerator.LookupTable` or a `coder.mathfcngenerator.Flat` configuration object

`coder.mathfcngenerator.LookupTable` configuration object |
`coder.mathfcngenerator.Flat` configuration object

Function replacement configuration object. Use the `coder.FixptConfig` configuration object `addApproximation` method to associate this configuration object with a `coder.FixptConfig` object. Then use the `codegen` function -`float2fixed` option with `coder.FixptConfig` to convert floating-point MATLAB code to fixed-point code.

Property	Default Value
Auto-replace function	''
InputRange	[]
FunctionNamePrefix	'replacement_'
Architecture	LookupTable (read only)
NumberOfPoints	1000
InterpolationDegree	1
ErrorThreshold	0.001

Property	Default Value
OptimizeLUTSize	false
OptimizeIterations	25

See Also

Classes

`coder.FixptConfig`

Functions

`codegen`

Topics

“Replace the exp Function with a Lookup Table”

“Replace a Custom Function with a Lookup Table”

“Replacing Functions Using Lookup Table Approximations”

Introduced in R2014b

coder.config

Create HDL Coder code generation configuration objects

Syntax

```
config_obj = coder.config('hdl')  
config_obj = coder.config('fixpt')
```

Description

`config_obj = coder.config('hdl')` creates a `coder.HdlConfig` configuration object for use with the HDL codegen function when generating HDL code from MATLAB code.

`config_obj = coder.config('fixpt')` creates a `coder.FixptConfig` configuration object for use with the HDL codegen function when generating HDL code from floating-point MATLAB code. The `coder.FixptConfig` object configures the floating-point to fixed-point conversion.

Examples

Generate HDL Code from Floating-Point MATLAB Code

Create a `coder.FixptConfig` object, `fixptcfg`, with default settings.

```
fixptcfg = coder.config('fixpt');
```

Set the test bench name. In this example, the test bench function name is `mlhdlc_dti_tb`.

```
fixptcfg.TestBenchName = 'mlhdlc_dti_tb';
```

Create a `coder.HdlConfig` object, `hdlcfg`, with default settings.

```
hdlcfg = coder.config('hdl');
```

Convert your floating-point MATLAB design to fixed-point, and generate HDL code. In this example, the MATLAB design function name is `mlhdlc_dti`.

```
codegen -float2fixed fixptcfg -config hdlcfg mlhdlc_dti
```

See Also

[codegen](#) | [coder.FixptConfig](#) | [coder.HdlConfig](#)

Topics

“Generate HDL Code from MATLAB Code Using the Command Line Interface”

Introduced in R2013a

addDesignRangeSpecification

Class: coder.FixptConfig

Package: coder

Add design range specification to parameter

Syntax

```
addDesignRangeSpecification(fcnName,paramName,designMin, designMax)
```

Description

`addDesignRangeSpecification(fcnName,paramName,designMin, designMax)` specifies the minimum and maximum values allowed for the parameter, `paramName`, in function, `fcnName`. The fixed-point conversion process uses this design range information to derive ranges for downstream variables in the code.

Input Arguments

fcnName — Function name

string

Function name, specified as a string.

Data Types: char

paramName — Parameter name

string

Parameter name, specified as a string.

Data Types: char

designMin — Minimum value allowed for this parameter

scalar

Minimum value allowed for this parameter, specified as a scalar double.

Data Types: double

designMax — Maximum value allowed for this parameter

scalar

Maximum value allowed for this parameter, specified as a scalar double.

Data Types: double

Examples

See Also

addFunctionReplacement

Class: coder.FixptConfig

Package: coder

Replace floating-point function with fixed-point function during fixed-point conversion

Syntax

```
addFunctionReplacement(floatFn, fixedFn)
```

Description

`addFunctionReplacement(floatFn, fixedFn)` specifies a function replacement in a `coder.FixptConfig` object. During floating-point to fixed-point conversion in the HDL code generation workflow, the conversion process replaces the specified floating-point function with the specified fixed-point function. The fixed-point function must be in the same folder as the floating-point function or on the MATLAB path.

Input Arguments

floatFn — Name of floating-point function

'' (default) | string

Name of floating-point function, specified as a string.

fixedFn — Name of fixed-point function

'' (default) | string

Name of fixed-point function, specified as a string.

Examples

Specify Function Replacement in Fixed-Point Conversion Configuration Object

Create a fixed-point code configuration object, `fxpCfg`, with a test bench, `myTestbenchName`.

```
fxpCfg = coder.config('fixpt');  
fxpCfg.TestBenchName = 'myTestbenchName';  
fxpCfg.addFunctionReplacement('min', 'fi_min');  
codegen -float2fixed fxpCfg designName
```

Specify that the floating-point function, `min`, should be replaced with the fixed-point function, `fi_min`.

```
fxpCfg.addFunctionReplacement('min', 'fi_min');
```

When you generate code, the code generator replaces instances of `min` with `fi_min` during floating-point to fixed-point conversion.

Alternatives

You can specify function replacements in the HDL Workflow Advisor. See “Function Replacements”.

See Also

`codegen` | `coder.FixptConfig` | `coder.config`

clearDesignRangeSpecifications

Class: coder.FixptConfig

Package: coder

Clear all design range specifications

Syntax

```
clearDesignRangeSpecifications()
```

Description

clearDesignRangeSpecifications() clears all design range specifications.

Examples

Clear a Design Range Specification

```
% Set up the fixed-point configuration object
cfg = coder.config('fixpt');
cfg.TestBenchName = 'dti_test';
cfg.addDesignRangeSpecification('dti', 'u_in', -1.0, 1.0)
cfg.ComputeDerivedRanges = true;
% Verify that the 'dti' function parameter 'u_in' has design range
hasDesignRanges = cfg.hasDesignRangeSpecification('dti','u_in')
% Now remove the design range
cfg.clearDesignRangeSpecifications()
hasDesignRanges = cfg.hasDesignRangeSpecification('dti','u_in')
```

See Also

getDesignRangeSpecification

Class: coder.FixptConfig

Package: coder

Get design range specifications for parameter

Syntax

```
[designMin, designMax] = getDesignRangeSpecification(fcnName,paramName)
```

Description

[designMin, designMax] = getDesignRangeSpecification(fcnName,paramName) gets the minimum and maximum values specified for the parameter, paramName, in function, fcnName.

Input Arguments

fcnName — Function name

string

Function name, specified as a string.

Data Types: char

paramName — Parameter name

string

Parameter name, specified as a string.

Data Types: char

Output Arguments

designMin — Minimum value allowed for this parameter

scalar

Minimum value allowed for this parameter, specified as a scalar double.

Data Types: double

designMax — Maximum value allowed for this parameter

scalar

Maximum value allowed for this parameter, specified as a scalar double.

Data Types: double

Examples

Get Design Range Specifications

```
% Set up the fixed-point configuration object
cfg = coder.config('fixpt');
cfg.TestBenchName = 'dti_test';
cfg.addDesignRangeSpecification('dti', 'u_in', -1.0, 1.0)
cfg.ComputeDerivedRanges = true;
% Get the design range for the 'dti' function parameter 'u_in'
[designMin, designMax] = cfg.getDesignRangeSpecification('dti','u_in')
```

```
designMin =
```

```
    -1
```

```
designMax =
```

```
     1
```

See Also

hasDesignRangeSpecification

Class: `coder.FixptConfig`

Package: `coder`

Determine whether parameter has design range

Syntax

```
hasDesignRange = hasDesignRangeSpecification(fcnName,paramName)
```

Description

`hasDesignRange = hasDesignRangeSpecification(fcnName,paramName)` returns true if the parameter, `param_name` in function, `fcn`, has a design range specified.

Input Arguments

fcnName — Name of function

string

Function name, specified as a string.

Example: 'dti'

Data Types: `char`

paramName — Parameter name

string

Parameter name, specified as a string.

Example: 'dti'

Data Types: `char`

Output Arguments

hasDesignRange — Parameter has design range

true | false

Parameter has design range, returned as a boolean.

Data Types: `logical`

Examples

Verify That a Parameter Has a Design Range Specification

```
% Set up the fixed-point configuration object
cfg = coder.config('fixpt');
cfg.TestBenchName = 'dti_test';
```



```
cfg.addDesignRangeSpecification('dti', 'u_in', -1.0, 1.0);  
cfg.ComputeDerivedRanges = true;  
% Verify that the 'dti' function parameter 'u_in' has design range  
hasDesignRanges = cfg.hasDesignRangeSpecification('dti','u_in')
```

```
hasDesignRanges =
```

```
    1
```

See Also

removeDesignRangeSpecification

Class: coder.FixptConfig

Package: coder

Remove design range specification from parameter

Syntax

```
removeDesignRangeSpecification(fcnName,paramName)
```

Description

`removeDesignRangeSpecification(fcnName,paramName)` removes the design range information specified for parameter, `paramName`, in function, `fcnName`.

Input Arguments

fcnName — Name of function

string

Function name, specified as a string.

Data Types: char

paramName — Parameter name

string

Parameter name, specified as a string.

Data Types: char

Examples

Remove Design Range Specifications

```
% Set up the fixed-point configuration object
cfg = coder.config('fixpt');
cfg.TestBenchName = 'dti_test';
cfg.addDesignRangeSpecification('dti', 'u_in', -1.0, 1.0)
cfg.ComputeDerivedRanges = true;
% Verify that the 'dti' function parameter 'u_in' has design range
hasDesignRanges = cfg.hasDesignRangeSpecification('dti','u_in')
% Now clear the design ranges and verify that
% hasDesignRangeSpecification returns false
cfg.removeDesignRangeSpecification('dti', 'u_in')
hasDesignRanges = cfg.hasDesignRangeSpecification('dti','u_in')
```

See Also

Classes for HDL Code Generation from MATLAB

coder.FixptConfig class

Package: coder

Floating-point to fixed-point conversion configuration object

Description

A `coder.FixptConfig` object contains the configuration parameters that the HDL codegen function requires to convert floating-point MATLAB code to fixed-point MATLAB code during HDL code generation. Use the `-float2fixed` option to pass this object to the codegen function.

Construction

`fixptcfg = coder.config('fixpt')` creates a `coder.FixptConfig` object for floating-point to fixed-point conversion.

Properties

ComputeDerivedRanges

Enable derived range analysis.

Values: true|false (default)

ComputeSimulationRanges

Enable collection and reporting of simulation range data. If you need to run a long simulation to cover the complete dynamic range of your design, consider disabling simulation range collection and running derived range analysis instead.

Values: true (default)|false

DefaultFractionLength

Default fixed-point fraction length.

Values: 4 (default) | positive integer

DefaultSignedness

Default signedness of variables in the generated code.

Values: 'Automatic' (default) | 'Signed' | 'Unsigned'

DefaultWordLength

Default fixed-point word length.

Values: 14 (default) | positive integer

DetectFixptOverflows

Enable detection of overflows using scaled doubles.

Values: true| false (default)

fimath

fimath properties to use for conversion.

Values: fimath('RoundingMethod', 'Floor', 'OverflowAction', 'Wrap', 'ProductMode', 'FullPrecision', 'SumMode', 'FullPrecision') (default) | string

FixPtFileNameSuffix

Suffix for fixed-point file names.

Values: '_fixpt' | string

LaunchNumericTypesReport

View the numeric types report after the software has proposed fixed-point types.

Values: true (default) | false

LogIOForComparisonPlotting

Enable simulation data logging to plot the data differences introduced by fixed-point conversion.

Values: true (default) | false

OptimizeWholeNumber

Optimize the word lengths of variables whose simulation min/max logs indicate that they are always whole numbers.

Values: true (default) | false

PlotFunction

Name of function to use for comparison plots.

LogIOForComparisonPlotting must be set to true to enable comparison plotting. This option takes precedence over PlotWithSimulationDataInspector.

The plot function should accept three inputs:

- A structure that holds the name of the variable and the function that uses it.
- A cell array to hold the logged floating-point values for the variable.
- A cell array to hold the logged values for the variable after fixed-point conversion.

Values: '' (default) | string

PlotWithSimulationDataInspector

Use Simulation Data Inspector for comparison plots.

`LogIOForComparisonPlotting` must be set to true to enable comparison plotting. The `PlotFunction` option takes precedence over `PlotWithSimulationDataInspector`.

Values: true| false (default)

ProposeFractionLengthsForDefaultWordLength

Propose fixed-point types based on `DefaultWordLength`.

Values: true (default) | false

ProposeTargetContainerTypes

By default (false), propose data types with the minimum word length needed to represent the value. When set to true, propose data type with the smallest word length that can represent the range and is suitable for C code generation (8,16,32, 64 ...). For example, for a variable with range [0..7], propose a word length of 8 rather than 3.

Values: true| false (default)

ProposeWordLengthsForDefaultFractionLength

Propose fixed-point types based on `DefaultFractionLength`.

Values: false (default) | true

ProposeTypesUsing

Propose data types based on simulation range data, derived ranges, or both.

Values: 'BothSimulationAndDerivedRanges' (default) |
'SimulationRanges'|'DerivedRanges'

SafetyMargin

Safety margin percentage by which to increase the simulation range when proposing fixed-point types. The specified safety margin must be a real number greater than -100.

Values: 0 (default) | double

StaticAnalysisQuickMode

Perform faster static analysis.

Values: true | false (default)

StaticAnalysisTimeoutMinutes

Abort analysis if timeout is reached.

Values: '' (default) | positive integer

TestBenchName

Test bench function name or names, specified as a string or cell array of strings. You must specify at least one test bench.

If you do not explicitly specify input parameter data types, the conversion uses the first test bench function to infer these data types.

Values: '' (default) | string | cell array of strings

TestNumerics

Enable numerics testing.

Values: true| false (default)

Methods

addDesignRangeSpecification	Add design range specification to parameter
addFunctionReplacement	Replace floating-point function with fixed-point function during fixed-point conversion
clearDesignRangeSpecifications	Clear all design range specifications
getDesignRangeSpecification	Get design range specifications for parameter
hasDesignRangeSpecification	Determine whether parameter has design range
removeDesignRangeSpecification	Remove design range specification from parameter

Examples

Generate HDL Code from Floating-Point MATLAB Code

Create a `coder.FixptConfig` object, `fixptcfg`, with default settings.

```
fixptcfg = coder.config('fixpt');
```

Set the test bench name. In this example, the test bench function name is `mlhdlc_dti_tb`.

```
fixptcfg.TestBenchName = 'mlhdlc_dti_tb';
```

Create a `coder.HdlConfig` object, `hdlcfg`, with default settings.

```
hdlcfg = coder.config('hdl');
```

Convert your floating-point MATLAB design to fixed-point, and generate HDL code. In this example, the MATLAB design function name is `mlhdlc_dti`.

```
codegen -float2fixed fixptcfg -config hdlcfg mlhdlc_dti
```

Alternatives

You can also generate HDL code from MATLAB code using the HDL Workflow Advisor. For more information, see “Basic HDL Code Generation and FPGA Synthesis from MATLAB by Using the Workflow Advisor”.

See Also

`codegen` | `coder.HdlConfig` | `coder.config`

Topics

“Generate HDL Code from MATLAB Code Using the Command Line Interface”

coder.HdlConfig class

Package: coder

HDL codegen configuration object

Description

A `coder.HdlConfig` object contains the configuration parameters that the HDL codegen function requires to generate HDL code. Use the `-config` option to pass this object to the codegen function.

Construction

`hdlcfg = coder.config('hdl')` creates a `coder.HdlConfig` object for HDL code generation.

Properties

Basic

AdderSharingMinimumBitwidth

Minimum bit width for shared adders, specified as a positive integer.

If `ShareAdders` is `true` and `ResourceSharing` is greater than 1, share adders only if adder bit width is greater than or equal to `AdderSharingMinimumBitwidth`.

Values: integer greater than or equal to 2

ClockEdge

Specify active clock edge.

Values: 'Rising' (default) | 'Falling'

DistributedPipeliningPriority

Priority for distributed pipelining algorithm.

DistributedPipeliningPriority Value	Description
NumericalIntegrity (default)	<p>Prioritize numerical integrity when distributing pipeline registers.</p> <p>This option uses a conservative retiming algorithm that does not move registers across a component if the functional equivalence to the original design is unknown.</p>

DistributedPipeliningPriority Value	Description
Performance	<p>Prioritize performance over numerical integrity.</p> <p>Use this option if your design requires a higher clock frequency and the MATLAB behavior does not need to strictly match the generated code behavior.</p> <p>This option uses a more aggressive retiming algorithm that moves registers across a component even if the modified design's functional equivalence to the original design is unknown.</p>

Values: 'NumericalIntegrity' (default) | 'Performance'

GenerateHDLTestBench

Generate an HDL test bench, specified as a logical.

Values: false (default) | true

HDLCodingStandard

HDL coding standard to follow and check when generating code. Generates a compliance report showing errors, warnings, and messages.

Values: 'None' (default) | 'Industry'

HDLCodingStandardCustomizations

HDL coding standard rules and report customizations, specified using HDL coding standard customization. If you want to customize the coding standard rules and report, you must set HDLCodingStandard to 'Industry'.

Value: HDL coding standard customization object

HDLLintTool

HDL lint tool script to generate.

Values: 'None' (default) | 'AscentLint' | 'Leda' | 'SpyGlass' | 'Custom'

HDLLintInit

HDL lint script initialization name, specified as a character vector.

HDLLintCmd

HDL lint script command.

If you set HDLLintTool to Custom, you must use %s as a placeholder for the HDL file name in the generated Tcl script. Specify HDLLintCmd as a character vector using the following format:

```
custom_lint_tool_command -option1 -option2 %s
```

HDLLintTerm

HDL lint script termination name, specified as a character vector.

InitializeBlockRAM

Specify whether to initialize all block RAM to '0' for simulation.

Values: true (default) | false

InlineConfigurations

Specify whether to include inline configurations in generated VHDL code.

When true, include VHDL configurations in files that instantiate a component.

When false, suppress the generation of configurations and require user-supplied external configurations. Set to false if you are creating your own VHDL configuration files.

Values: true (default) | false

LoopOptimization

Loop optimization in generated code. See “Optimize MATLAB Loops”.

LoopOptimization Value	Description
LoopNone (default)	Do not optimize loops in generated code.
StreamLoops	Stream loops.
UnrollLoops	Unroll Loops.

MinimizeClockEnables

Specify whether to omit generation of clock enable logic.

When true, omit generation of clock enable logic wherever possible.

When false (default), generate clock enable logic.

MultiplierPartitioningThreshold

Specify maximum input bit width for hardware multipliers. If a multiplier input bit width is greater than this threshold, HDL Coder splits the multiplier into smaller multipliers.

To improve your hardware mapping results, set this threshold to the input bit width of the DSP or multiplier hardware on your target device.

Values: integer greater than or equal to 2

MultiplierSharingMinimumBitwidth

Minimum bit width for shared multipliers, specified as a positive integer.

If ShareMultipliers is true and ResourceSharing is greater than 1, share multipliers only if multiplier bit width is greater than or equal to MultiplierSharingMinimumBitwidth.

Values: integer greater than or equal to 2

InstantiateFunctions

Generate instantiable HDL code modules from functions.

Note If you enable `InstantiateFunctions`, `UseMatrixTypesInHDL` has no effect.

Values: `false` (default) | `true`

PreserveDesignDelays

Prevent distributed pipelining from moving design delays or allow distributed pipelining to move design delays, specified as a `logical`.

Persistent variables and `dsp.Delay System` objects are design delays.

Values: `false` (default) | `true`

ShareAdders

Share adders, specified as a `logical`.

If `true`, share adders when `ResourceSharing` is greater than 1 and adder bit width is greater than or equal to `AdderSharingMinimumBitwidth`.

Values: `false` (default) | `true`

ShareMultipliers

Share multipliers, specified as a `logical`.

If `true`, share multipliers when `ResourceSharing` is greater than 1, and multiplier bit width is greater than or equal to `MultiplierSharingMinimumBitwidth`.

Values: `true` (default) | `false`

SimulateGeneratedCode

Simulate generated code, specified as a `logical`.

Values: `false` (default) | `true`

SimulationIterationLimit

Maximum number of simulation iterations during test bench generation, specified as an integer. This property affects only test bench generation, not simulation during fixed-point conversion.

Values: unlimited (default) | positive integer

SimulationTool

Simulation tool name.

Values: `'ModelSim'` (default) | `'ISIM'`

SynthesisTool

Synthesis tool name.

Values: 'Xilinx ISE' (default) | 'Altera Quartus II' | 'Xilinx Vivado'

SynthesisToolChipFamily

Synthesis target chip family name, specified as a character vector.

Values: 'Virtex4' (default) | 'Family name'

SynthesisToolDeviceName

Synthesis target device name, specified as a character vector.

Values: 'xc4vsx35' (default) | 'Device name'

SynthesisToolPackageName

Synthesis target package name, specified as a character vector.

Values: 'ff668' (default) | 'Package name'

SynthesisToolSpeedValue

Synthesis target speed, specified as a character vector.

Values: '-10' (default) | 'Speed value'

SynthesizeGeneratedCode

Synthesize generated code or not, specified as a logical.

Values: false (default) | true

TargetLanguage

Target language of the generated code.

Values: 'VHDL' (default) | 'Verilog'

TestBenchName

Test bench function name, specified as a character vector. You must specify a test bench.

Values: '' (default) | 'Testbench name'

TimingControllerArch

Timing controller architecture.

TimingControllerArch Value	Description
default (default)	Do not generate a reset for the timing controller.
resettable	Generate a reset for the timing controller.

TimingControllerPostfix

Postfix to append to design name to form name of timing controller, specified as a character vector.

Values: `'_tc'` (default) | `'Postfix'`

UseFileIOInTestBench

Create and use data files for reading and writing test bench input and output data.

Values: `'on'` (default) | `'off'`

UseMatrixTypesInHDL

Generate 2-D matrix types in HDL code for MATLAB matrices, specified as a `logical`.

UseMatrixTypesInHDL Value	Description
<code>false</code> (default)	Generate HDL vectors with index computation logic for MATLAB matrices. This option can use more area in the synthesized hardware.
<code>true</code>	<p>Generate HDL matrices for MATLAB matrices. This option can save area in the synthesized hardware.</p> <p>The following requirements apply:</p> <ul style="list-style-type: none"> Matrix elements cannot be complex or <code>struct</code> data types. You cannot use linear indexing to specify matrix elements. For example, if you have a 3x3 matrix, <code>A</code>, you cannot use <code>A(4)</code>. Instead, use <code>A(2,1)</code>. <p>You can also use a colon operator in either the row or column subscript, but not both. For example, you can use <code>A(3,1:3)</code> and <code>A(2:3,1)</code>, but not <code>A(2:3, 1:3)</code>.</p> <ul style="list-style-type: none"> If you enable <code>InstantiateFunctions</code>, <code>UseMatrixTypesInHDL</code> has no effect.

VHDLLibraryName

Target library name for generated VHDL code, specified as a character vector.

Values: `'work'` (default) | `'Library name'`

Cosimulation

GenerateCosimTestBench

Generate a cosimulation test bench or not, specified as a `logical`.

Values: `false` (default) | `true`

SimulateCosimTestBench

Simulate generated cosimulation test bench, specified as a `logical`. This option is ignored if `GenerateCosimTestBench` is `false`.

Values: `false` (default) | `true`

CosimClockEnableDelay

Time (in clock cycles) between deassertion of reset and assertion of clock enable.

Values: 0 (default)

CosimClockHighTime

The number of nanoseconds the clock is high.

Values: 5 (default)

CosimClockLowTime

The number of nanoseconds the clock is low.

Values: 5 (default)

CosimHoldTime

The hold time for input signals and forced reset signals, specified in nanoseconds.

Values: 2 (default)

CosimLogOutputs

Log and plot outputs of the reference design function and HDL simulator.

Values: `false` (default) | `true`

CosimResetLength

Specify time (in clock cycles) between assertion and deassertion of reset.

Values: 2 (default)

CosimRunMode

HDL simulator run mode during simulation. When in Batch mode, you do not see the HDL simulator GUI, and the HDL simulator automatically shuts down after simulation.

Values: `Batch` (default) | `GUI`

CosimTool

HDL simulator for the generated cosim test bench.

Values: `ModelSim` (default) | `Incisive`

FPGA-in-the-loop

GenerateFILTestBench

Generate a FIL test bench or not, specified as a `logical`.

Values: false (default) | true

SimulateFILTestBench

Simulate generated cosimulation test bench, specified as a logical. This option is ignored if `GenerateCosimTestBench` is false.

Values: false (default) | true

FILBoardName

FPGA board name, specified as a character vector. You must override the default value and specify a valid board name.

Values: 'Choose a board' (default) | 'A board name'

FILBoardIPAddress

IP address of the FPGA board, specified as a character vector. You must enter a valid IP address.

Values: 192.168.0.2 (default)

FILBoardMACAddress

MAC address of the FPGA board, specified as a character vector. You must enter a valid MAC address.

Values: 00-0A-35-02-21-8A (default)

FILAdditionalFiles

List of additional source files to include, specified as a character vector. Separate file names with a semi-colon (";").

Values: '' (default) | 'Additional source files'

FILLogOutputs

Log and plot outputs of the reference design function and FPGA.

Values: false (default) | true

Examples

Generate Verilog Code from MATLAB Code

Create a `coder.HdlConfig` object, `hdlcfg`.

```
hdlcfg = coder.config('hdl'); % Create a default 'hdl' config
```

Set the test bench name. In this example, the test bench function name is `mlhdlc_dti_tb`.

```
hdlcfg.TestBenchName = 'mlhdlc_dti_tb';
```

Set the target language to Verilog.

```
hdlcfg.TargetLanguage = 'Verilog';
```

Generate HDL code from your MATLAB design. In this example, the MATLAB design function name is `mlhdlc_dti`.

```
codegen -config hdlcfg mlhdlc_dti
```

Generate Cosim and FIL Test Benches

Create a `coder.FixptConfig` object with default settings and provide test bench name.

```
fixptcfg = coder.config('fixpt');
fixptcfg.TestBenchName = 'mlhdlc_sfir_tb';
```

Create a `coder.HdlConfig` object with default settings and set enable rate.

```
hdlcfg = coder.config('hdl'); % Create a default 'hdl' config
hdlcfg.EnableRate = 'DUTBaseRate';
```

Instruct MATLAB to generate a cosim test bench and a FIL test bench. Specify FPGA board name.

```
hdlcfg.GenerateCosimTestBench = true;
hdlcfg.FILBoardName = 'Xilinx Virtex-5 XUPV5-LX110T development board';
hdlcfg.GenerateFILTestBench = true;
```

Perform code generation, Cosim test bench generation, and FIL test bench generation.

```
codegen -float2fixed fixptcfg -config hdlcfg mlhdlc_sfir
```

Alternatives

You can also generate HDL code from MATLAB code using the HDL Workflow Advisor. For more information, see “Basic HDL Code Generation and FPGA Synthesis from MATLAB by Using the Workflow Advisor”.

See Also

Functions

`codegen` | `coder.config` | `hdlcoder.CodingStandard`

Classes

`coder.FixptConfig`

Properties

HDL Coding Standard Customization

Topics

“Generate HDL Code from MATLAB Code Using the Command Line Interface”

Shared Classes and Functions for HDL Code Generation from MATLAB and Simulink

hdlcoder.CodingStandard

Create HDL coding standard customization object

Syntax

```
cso = hdlcoder.CodingStandard(standardName)
```

Description

`cso = hdlcoder.CodingStandard(standardName)` creates an HDL coding standard customization object that you can use to customize the rules and the appearance of the coding standard report.

If you do not want to customize the rules or appearance of the coding standard report, you do not need to create an HDL coding standard customization object.

Examples

Customize coding standard rules for MATLAB to HDL workflow

Create an HDL coding standard customization object, *cso*.

```
cso = hdlcoder.CodingStandard('Industry');
```

Customize the coding standard options as follows:

- Do not show passing rules in the coding standard report.
- Set the maximum if-else nesting depth to 2.
- Disable the check for line length.

```
cso.ShowPassingRules.enable = false;  
cso.IfElseNesting.depth = 2;  
cso.LineLength.enable = false;
```

Create an HDL codegen configuration object.

```
hdlcfg = coder.config('hdl');
```

Specify the coding standard and coding standard customization object.

```
hdlcfg.HDLCodingStandard = 'Industry';  
hdlcfg.HDLCodingStandardCustomizations = cso;
```

Specify your test bench function name. In this example, the test bench function is *mlhdlc_dti_tb*.

```
hdlcfg.TestBenchName = 'mlhdlc_dti_tb';
```

Generate HDL code for the design and check the code according to the customized HDL coding standard rules. In this example, the design function is *mlhdlc_dti*.

```
codegen -config hdlcfg mlhdlc_dti
```

Customize coding standard rules for Simulink to HDL workflow

Create an HDL coding standard customization object

- Load the `sfir_fixed` model
- Create a coding standard customization object `cso`

```
load_system('sfir_fixed')
cso = hdlcoder.CodingStandard('Industry');
```

Customize the coding standard options

- Do not show passing rules in the report.
- Set maximum line length to 80 characters.
- Check that module, instance, and entity names are between 5 and 50 characters long.

```
cso.ShowPassingRules.enable = false;
cso.LineLength.length = 80;
cso.ModuleInstanceEntityNameLength.length = [5 50];
```

Generate HDL code for your design

Generate HDL code and check it according to the customized HDL coding standard rules. The DUT subsystem is `symmetric_fir`.

```
makehdl('sfir_fixed/symmetric_fir','HDLCodingStandard','Industry',...
        'HDLCodingStandardCustomizations',cso, 'TargetDirectory', 'C:/coding_standard/hdlsrc')

### Generating HDL for 'sfir_fixed/symmetric_fir'.
### Starting HDL check.
### Begin VHDL Code Generation for 'sfir_fixed'.
### Working on sfir_fixed/symmetric_fir as C:\coding_standard\hdlsrc\sfir_fixed\symmetric_fir.vhd
### Industry Compliance report with 4 errors, 77 warnings, 6 messages.
### Generating Industry Compliance Report <a href="matlab:web('C:\coding_standard\hdlsrc\sfir_fixed\symmetric_fir_report.html')">matlab:web('C:\coding_standard\hdlsrc\sfir_fixed\symmetric_fir_report.html')</a>
### Creating HDL Code Generation Check Report file://C:\coding_standard\hdlsrc\sfir_fixed\symmetric_fir_report.html
### HDL check for 'sfir_fixed' complete with 0 errors, 0 warnings, and 0 messages.
### HDL code generation complete.
```

Input Arguments

standardName — HDL coding standard name

'Industry'

Specify the HDL coding standard to customize. The `standardName` value must match the `HDLCodingStandard` property value.

Example: 'Industry'

Output Arguments

cso — HDL coding standard customizations

HDL coding standard customization object

HDL coding standard customizations, returned as an HDL coding standard customization object.

See Also

Properties

HDL Coding Standard Customization

Topics

“Generate an HDL Coding Standard Report from Simulink”

“Generate an HDL Coding Standard Report from MATLAB”

“Choose Coding Standard and Report Options”

“HDL Coding Standard Report”

Introduced in R2014b

HDL Coding Standard Customization Properties

Customize HDL coding standard

Description

HDL coding standard customization properties control how HDL Coder generates and checks code according to a specified coding standard. By changing property values, you can customize the rules and the appearance of the coding standard report.

Use dot notation to refer to a particular object and property:

```
cso = hdlcoder.CodingStandard('Industry');
len = cso.SignalPortParamNameLength.length;
cso.ShowPassingRules.enable = false;
```

The generated code follows the customized coding standard rules as much as possible. However, if following a coding standard rule could cause the HDL code to be uncompileable or unsynthesizable, the coder does not follow the rule.

Properties

Coding Standard Report

ShowPassingRules — Show passing rules in coding standard report

structure

Show or do not show passing rules in coding standard report, specified as a structure with the following field.

Field	Description
enable	Set to <code>true</code> to show passing rules in coding standard report. Set to <code>false</code> to show only rules with errors or warnings. The default is <code>true</code> .

Basic Coding Rules

HDLKeywords — Check for HDL keywords in design names

structure

Check for HDL keywords in design names (rule CGSL-1.A.A.3), specified as a structure with the following field.

Field	Description
enable	Set to <code>true</code> to check for HDL keywords in design names. Set to <code>false</code> if you do not want to check for HDL keywords in design names. The default is <code>true</code> .

DetectDuplicateNamesCheck — Check for duplicate names

structure

Check for duplicate names in the design (rule CGSL-1.A.A.5), specified as a structure with the following field.

Field	Description
enable	Set to <code>true</code> to check for duplicate names in the design. Set to <code>false</code> if you do not want to check for duplicate names in the design. The default is <code>true</code> .

ModuleInstanceEntityNameLength — Check module, instance, and entity name length

structure

Check for module, instance, and entity name lengths (rule CGSL-1.A.B.1), specified as a structure with the following fields.

Field	Description
enable	Set to <code>true</code> to check the length of module, instance, and entity names. Set to <code>false</code> if you do not want to check the length of module, instance, and entity names. The default is <code>true</code> .
length	Minimum and maximum length of module, instance, and entity name names, specified as a 2-element array of positive integers. The first element is the minimum length, and the second element is the maximum length. The default is [2 32].

SignalPortParamNameLength — Check signal, port, and parameter name length

structure

Check for signal, port, and parameter name lengths (rule CGSL-1.A.C.3), specified as a structure with the following fields.

Field	Description
enable	<p>Set to <code>true</code> to check the length of signal, port, and parameter names.</p> <p>Set to <code>false</code> if you do not want to check the length of signal, port, and parameter names.</p> <p>The default is <code>true</code>.</p>
length	<p>Minimum and maximum length of signal, port, and parameter names, specified as a 2-element array of positive integers.</p> <p>The first element is the minimum length, and the second element is the maximum length. The default is [2 40].</p>

RTL Description Rules

MinimizeClockEnableCheck — Check for clock enable signals

structure

Check for clock enable signals in the generated code (rule CGSL-2.C.C.4), specified as a structure with the following field.

Field	Description
enable	<p>Set to <code>true</code> to minimize clock enables in the generated code and check for clock enable signals after code generation.</p> <p>Set to <code>false</code> if you do not want to check for clock enable signals in the generated code.</p> <p>The default is <code>false</code>.</p>

RemoveResetCheck — Check for reset signals

structure

Check for reset signals in the design (rule CGSL-2.C.C.5), specified as a structure with the following field.

Field	Description
enable	<p>Set to <code>true</code> to minimize reset signals in the generated code and check for reset signals after code generation.</p> <p>Set to <code>false</code> if you do not want to check for reset signals in the design.</p> <p>The default is <code>false</code>.</p>

AsynchronousResetCheck — Check for asynchronous reset signals in the generated code

structure

Check for asynchronous reset signals in the generated code (CGSL-2.C.C.6), specified as a structure with the following field.

Field	Description
enable	Set to <code>true</code> to check for asynchronous reset signals in the generated code. Set to <code>false</code> if you do not want to check for asynchronous reset signals in the generated code. The default is <code>true</code> .

MinimizeVariableUsage – Minimize use of variables

structure

Minimize use of variables (rule CGSL-2.G), specified as a structure with the following field.

Field	Description
enable	Set to <code>true</code> to minimize use of variables. Set to <code>false</code> if you do not want to minimize use of variables. The default is <code>false</code> .

ConditionalRegionCheck – Check for length of conditional statements in a process or always block

structure

Check for length of conditional statements (if-else, case, and loops) which are described separately in a process block or an always block (rule CGSL-2.F.B.1), specified as a structure with the following fields.

Field	Description
enable	Set to <code>true</code> to check length of conditional statements. Set to <code>false</code> if you do not want to check the length of conditional statements. The default is <code>true</code> .
length	Number of conditional statements which are described separately within a process block (VHDL) or an always block (Verilog). The default is 1.

IfElseNesting – Check if-else statement nesting depth

structure

Check for if-else statement nesting depth (rule CGSL-2.G.C.1a), specified as a structure with the following fields.

Field	Description
enable	Set to <code>true</code> to check if-else statement nesting depth. Set to <code>false</code> if you do not want to check if-else statement nesting depth. The default is <code>true</code> .
depth	Maximum if-else statement nesting depth, specified as a positive integer. The default is 3.

IfElseChain – Check if-else statement chain length

structure

Check for if-else statement chain length (rule CGSL-2.G.C.1c), specified as a structure with the following fields.

Field	Description
enable	Set to <code>true</code> to check if-else statement chain length. Set to <code>false</code> if you do not want to check if-else statement chain length. The default is <code>true</code> .
length	Maximum length of if-else statement chain, specified as a positive integer. The default is 7.

MultiplierBitWidth – Check multiplier bit width

structure

Check for multiplier bit width (rule CGSL-2.J.F.5), specified as a structure with the following fields.

Field	Description
enable	Set to <code>true</code> to check multiplier bit width. Set to <code>false</code> if you do not want to check multiplier bit width. The default is <code>true</code> .
width	Maximum multiplier bit width, specified as a positive integer. The default is 16.

RTL Design Rules**LineLength – Check generated code line length**

structure

Check for generated code line length (rule CGSL-3.A.D.5), specified as a structure with the following fields.

Field	Description
enable	Set to <code>true</code> to check line lengths in generated code. Set to <code>false</code> if you do not want to check line lengths in generated code. The default is <code>true</code> .
length	Maximum number of characters per line in generated code, specified as a positive integer. The default is 110.

NonIntegerTypes — Check for non-integer constants

structure

Check for non-integer constants (rule CGSL-3.B.D.1), specified as a structure with the following field.

Field	Description
enable	Set to <code>true</code> to check for non-integer constants. Set to <code>false</code> if you do not want to check for non-integer constants. The default is <code>true</code> .

See Also

`hdlcoder.CodingStandard`

Topics

“Generate an HDL Coding Standard Report from MATLAB”

“Generate an HDL Coding Standard Report from Simulink”

“HDL Coding Standard Report”

“Basic Coding Practices”

“RTL Description Techniques”

“RTL Design Methodology Guidelines”

hdl.BlackBox

Package: hdl

Black box for including custom HDL code

Description

`hdl.BlackBox` provides a way to include custom HDL code, such as legacy or handwritten HDL code, in a MATLAB design intended for HDL code generation.

When you create a user-defined System object that inherits from `hdl.BlackBox`, you specify a port interface and simulation behavior that matches your custom HDL code.

HDL Coder simulates the design in MATLAB using the behavior you define in the System object. During code generation, instead of generating code for the simulation behavior, the coder instantiates a module with the port interface you specify in the System object.

To use the generated HDL code in a larger system, you include the custom HDL source files with the rest of the generated code.

To include custom HDL code:

- 1 Create the `hdl.BlackBox` object and set its properties.
- 2 Call the object with arguments, as if it were a function.

To learn more about how System objects work, see [What Are System Objects? \(MATLAB\)](#).

Note Starting in R2016b, instead of using the `step` method to perform the operation defined by the System object, you can call the object with arguments, as if it were a function. For example, `y = step(obj,x)` and `y = obj(x)` perform equivalent operations.

Creation

Syntax

```
B = hdl.BlackBox
```

Description

`B = hdl.BlackBox` creates a black box System object for HDL code generation.

Properties

Unless otherwise indicated, properties are *nontunable*, which means you cannot change their values after calling the object. Objects lock when you call them, and the `release` function unlocks them.

If a property is *tunable*, you can change its value at any time.

For more information on changing property values, see *System Design in MATLAB Using System Objects (MATLAB)*.

Note You cannot specify clock, reset, and clock enable signals explicitly in your Simulink model by using the **AddClockEnablePort**, **AddClockPort**, and **AddResetPort** properties. Instead, use these properties to add a clock, reset, or clock enable port in the generated HDL code.

AddClockEnablePort — Add clock enable port

'on' (default) | 'off'

If 'on', add a clock enable input port to the interface generated for the black box System object. The name of the port is specified by `ClockEnableInputPort`.

AddClockPort — Add clock port

'on' (default) | 'off'

If 'on', add a clock input port to the interface generated for the black box System object. The name of the port is specified by `ClockInputPort`.

AddResetPort — Add reset port

'on' (default) | 'off'

If 'on', add a reset input port to the interface generated for the black box System object. The name of the port is specified by `ResetInputPort`.

AllowDistributedPipelining — Register placement for distributed pipelining

'off' (default) | 'on'

If 'on', allow HDL Coder to move registers across the black box System object, from input to output or output to input.

ClockEnableInputPort — Clock enable input port name

'clk_enable' (default) | character vector

HDL name for clock enable input port, specified as a character vector.

ClockInputPort — Clock input port name

'clk' (default) | character vector

HDL name for clock input port, specified as a character vector.

EntityName — Module or entity name

System object instance name (default) | character vector

VHDL entity or Verilog module name generated for the black box System object, specified as a character vector.

Example: 'myBlackBoxName'

ImplementationLatency — Latency in clock cycles

-1 (default) | integer

Latency of black box System object in clock cycles, specified as an integer.

If 0 or greater, this value is used for delay balancing.

If -1, latency is unknown. This disables delay balancing.

InlineConfigurations — Generate VHDL configuration

InlineConfigurations global property value (default) | 'on' | 'off'

When 'on', generate a VHDL configuration.

When 'off', do not generate a VHDL configuration and require a user-supplied external configuration. Set to 'off' if you are creating your own VHDL configuration.

InputPipeline — Input pipeline stages

0 (default) | positive integer

Number of input pipeline stages, or pipeline depth, to insert in the generated code.

OutputPipeline — Output pipeline stages

0 (default) | positive integer

Number of output pipeline stages, or output pipeline depth, to insert in the generated code.

ResetInputPort — Reset port name

'reset' (default) | character vector

HDL name for reset input port, specified as a character vector.

VHDLArchitectureName — VHDL architecture name

'rtl' (default) | character vector

VHDL architecture name, specified as a character vector. The coder generates the architecture name only if InlineConfigurations is 'on'.

VHDLComponentLibrary — VHDL component library name

'work' (default) | character vector

Library from which to load the VHDL component, specified as a character vector.

NumInputs — Number of custom input ports

1 (default) | positive integer

Number of additional input ports in the custom HDL code, specified as a positive integer.

NumOutputs — Number of custom output ports

1 (default) | positive integer

Number of additional output ports in the custom HDL code, specified as a positive integer.

Object Functions

To use an object function, specify the System object as the first input argument. For example, to release system resources of a System object named obj, use this syntax:

```
release(obj)
```

Common to All System Objects

step Run System object algorithm
release Release resources and allow changes to System object property values and input characteristics
reset Reset internal states of System object

Extended Capabilities

HDL Code Generation

Generate Verilog and VHDL code for FPGA and ASIC designs using HDL Coder™.

See Also

`coder.HdlConfig`

Topics

“Integrate Custom HDL Code Into MATLAB Design”

“Generate Board-Independent IP Core from MATLAB Algorithm”

“Generate Black Box Interface for Subsystem”

Introduced in R2015a

hdl.RAM

Package: hdl

Single, simple dual, or dual-port RAM for memory read/write access

Description

hdl.RAM reads from and writes to memory locations for a single, simple dual, or dual-port RAM. The output data is delayed one step. If your input data is scalar, the address and write enable inputs must be scalar, and HDL Coder infers a single RAM block. If your data is a vector, HDL Coder infers an array of parallel RAM banks. With vector data input, the address and write enable inputs can be both scalars or vectors. When you specify scalar inputs for the write enable and address ports, the system object applies the same operation to each RAM bank.

The hdl.RAM System object can have 2^{31} bytes of internal storage. The RAM size takes into account the address width, the number of bytes that are used to store each word, and the number of RAM banks.

To read from or write to memory locations in the RAM:

- 1 Create the hdl.RAM object and set its properties.
- 2 Call the object with arguments, as if it were a function.

To learn more about how System objects work, see [What Are System Objects? \(MATLAB\)](#).

Creation

Syntax

```
ram = hdl.RAM  
ram = hdl.RAM(Name, Value)
```

Description

ram = hdl.RAM returns a single port RAM System object that you can write to or read from a memory location.

ram = hdl.RAM(Name, Value) returns a single, simple dual, or dual port RAM System object with properties set using one or more name-value pairs. Enclose each property name in single quotes.

Properties

Unless otherwise indicated, properties are *nontunable*, which means you cannot change their values after calling the object. Objects lock when you call them, and the `release` function unlocks them.

If a property is *tunable*, you can change its value at any time.

For more information on changing property values, see [System Design in MATLAB Using System Objects \(MATLAB\)](#).

RAMType — Type of RAM`'Single port' (default) | 'Simple dual port' | 'Dual port'`

Type of RAM, specified as either:

- `'Single port'` — Create a single port RAM with Write data, Address, and Write enable as inputs and Read data as the output.
- `'Simple dual port'` — Create a simple dual port RAM with Write data, Write address, Write enable, and Read address as inputs and data from read address as the output.
- `'Dual port'` — Create a dual port RAM with Write data, Write address, Write enable, and Read address as inputs and data from read address and write address as the outputs.

WriteOutputValue — Behavior for Write output`'New data' (default) | 'Old data'`

Behavior for Write output, specified as either:

- `'New data'` — Send out new data at the address to the output.
- `'Old data'` — Send out old data at the address to the output.

Dependencies

Specify this property when you set **RamType** to `'Single port'` or `'Dual port'`. This property does not apply for Simple Dual Port RAM object.

RAMInitialValue — Initial output of RAM`'0.0' (default) | Scalar | Vector`

Initial simulation output of the System object, specified as either:

- A scalar value.
- A vector with one-to-one mapping between the initial value and the RAM words.

Usage**Syntax**

```
dataOut = ram(wrData, rwAddress, wrEn)
```

```
rdDataOut = ram(wrData, wrAddress, wrEn, rdAddress)
```

```
[wrDataOut, rdDataOut] = ram(wrData, wrAddress, wrEn, rdAddress)
```

Description

`dataOut = ram(wrData, rwAddress, wrEn)` reads the value in memory location `rwAddress` when `wrEn` is false. When `wrEn` is true, you write the value `wrData` into the memory location `rwAddress`. `dataOut` is the new or old data at `rwAddress`. Use this syntax when you create a single port RAM System object.

`rdDataOut = ram(wrData, wrAddress, wrEn, rdAddress)` writes the value `wrData` into memory location `wrAddress` when `wrEn` is true. `rdDataOut` is the old data at the address location `rdAddress`. Use this syntax when you create a simple dual port RAM System object.

`[wrDataOut, rdDataOut] = ram(wrData, wrAddress, wrEn, rdAddress)` writes the value `wrData` into the memory location `wrAddress` when `wrEn` is true. `wrDataOut` is the new or old data at memory location `wrAddress`. `rdDataOut` is the old data at the address location `rdAddress`. Use this syntax when you create a dual port RAM System object.

Input Arguments

wrData — Write data

Scalar (default) | Vector

Data that you write into the RAM memory location when `wrEn` is true. This value can be double, single, integer, or a fixed-point (`fi`) object, and can be real or complex.

Data Types: `single` | `double` | `int8` | `int16` | `uint8` | `uint16` | `fi`

rwAddress — Write or Read address

Scalar (default) | Vector

Address that you write the `wrData` into when `wrEn` is true. The System object reads the value in memory location `rwAddress` when `wrEn` is false. This value can be either fixed-point (`fi`) or integer, must be unsigned, and must be between 2 and 31 bits long. Specify this address when you create a single port RAM object.

Data Types: `uint8` | `uint16` | `fi`

wrEn — Write enable

Scalar (default) | Vector

When `wrEn` is true, you write the `wrData` into the RAM memory location. If you create a single port RAM, the System object reads the value in the memory location when `wrEn` is false. This value must be logical.

Data Types: `logical`

rdAddress — Read address

Scalar (default) | Vector

Address that you read the data from when you create a simple dual port RAM or dual port RAM System object. This value can be either fixed-point (`fi`) or integer, must be unsigned, and must be between 2 and 31 bits long.

Data Types: `uint8` | `uint16` | `fi`

wrAddress — Write address

Scalar (default) | Vector

Address that you write the data into when you create a simple dual port RAM or dual port RAM System object. This value can be either fixed-point (`fi`) or integer, must be unsigned, and must be between 2 and 31 bits long.

Data Types: `uint8` | `uint16` | `fi`

Output Arguments

dataOut — Output data

Scalar (default) | Vector

Output data that the System object reads from the memory location `rwAddress` a single port RAM object when `wrEn` is false.

rdDataOut — Data from Read address

Scalar (default) | Vector

Old output data that the System object reads from the memory location `rdAddress` of a simple dual port RAM or dual port RAM System object.

wrDataOut — Data from Write address

Scalar (default) | Vector

New or old output data that the System object reads from the memory location `wrAddress` of a simple dual port RAM or dual port RAM System object.

Object Functions

To use an object function, specify the System object as the first input argument. For example, to release system resources of a System object named `obj`, use this syntax:

```
release(obj)
```

Common to All System Objects

<code>step</code>	Run System object algorithm
<code>release</code>	Release resources and allow changes to System object property values and input characteristics
<code>reset</code>	Reset internal states of System object

Examples

Observe Previous Data at Write Time

Construct System object to read from or write to a memory location in RAM. Set `WriteOutputValue` to `Old data` to return the previous value stored at the write address.

The output data port corresponds to the read/write address passed in. During a write operation, the old data at the write address is sent out as the output.

Note: This object syntax runs only in R2016b or later. If you are using an earlier release, replace each call of an object with the equivalent `step` syntax. For example, replace `myObject(x)` with `step(myObject,x)`.

```
ram_1p = hdl.RAM('RAMType','Single port',...  
               'WriteOutputValue','Old data')
```

```
ram_1p =  
    hdl.RAM with properties:  
        RAMType: 'Single port'  
    WriteOutputValue: 'Old data'  
    RAMInitialValue: 0
```

```

dataLength = 10;
dataIn = 1:10;
dataOut = zeros(1,dataLength);

```

Write a count pattern to the memory. Previous values on the first writes are all zero.

```

for ii = 1:dataLength
    addressIn = uint8(ii-1);
    writeEnable = true;
    dataOut(ii) = ram_lp(dataIn(ii),addressIn,writeEnable);
end
dataOut

```

```
dataOut = 1×10
```

```

0 0 0 0 0 0 0 0 0 0

```

Read the data back.

```

for ii = 1:dataLength
    addressIn = uint8(ii-1);
    writeEnable = false;
    dataOut(ii) = ram_lp(dataIn(ii),addressIn,writeEnable);
end
dataOut

```

```
dataOut = 1×10
```

```

0 1 2 3 4 5 6 7 8 9

```

Now, write the count in reverse order. The previous values are the original count.

```

for ii = 1:dataLength
    addressIn = uint8(ii-1);
    writeEnable = true;
    dataOut(ii) = ram_lp(dataIn(dataLength-ii+1),addressIn,writeEnable);
end
dataOut

```

```
dataOut = 1×10
```

```

10 1 2 3 4 5 6 7 8 9

```

Read/Write Single-Port RAM

Create System object that writes to a single port RAM and reads the newly written value.

Note: This object syntax runs only in R2016b or later. If you are using an earlier release, replace each call of an object with the equivalent `step` syntax. For example, replace `myObject(x)` with `step(myObject,x)`.

Construct single-port RAM System object. When you write a location, the object returns the new value. The size of the RAM is inferred from the bitwidth of the address and write data on the first call to the object.

```
ram_lp = hdl.RAM('RAMType','Single port','WriteOutputValue','New data');
dataLength = 16;
[dataIn,dataOut] = deal(uint8(zeros(1,dataLength)));
```

Write randomly generated data to the System object, and then read data back out again.

```
for ii = 1:dataLength
    dataIn(ii) = randi([0 63],1,1,'uint8');
    addressIn = fi((ii-1),0,4,0);
    writeEnable = true;
    dataOut(ii) = ram_lp(dataIn(ii),addressIn,writeEnable);
end
```

```
dataOut
```

```
dataOut = 1x16 uint8 row vector
```

```
    0    52    57     8    58    40     6    17    35    61    61    10    62    61    31    51
```

```
for ii = 1:dataLength
    addressIn = fi((ii-1),0,4,0);
    writeEnable = false;
    dataOut(ii) = ram_lp(dataIn(ii),addressIn,writeEnable);
end
```

```
dataOut
```

```
dataOut = 1x16 uint8 row vector
```

```
     9    52    57     8    58    40     6    17    35    61    61    10    62    61    31    51
```

Create Simple Dual-Port RAM System Object

Construct System object to read from and write to different memory locations in RAM.

The output data port corresponds to the read address. If a read operation is performed at the same address as the write operation, old data at that address is read out as the output. The size of the RAM is inferred from the bitwidth of the address and write data on the first call to the object.

Note: This object syntax runs only in R2016b or later. If you are using an earlier release, replace each call of an object with the equivalent `step` syntax. For example, replace `myObject(x)` with `step(myObject,x)`.

```
ram_2p = hdl.RAM('RAMType','Simple dual port');
dataLength = 16;
[dataIn,dataOut] = deal(uint8(zeros(1,dataLength)));
```

Write randomly generated data to the System object, and read the old data from the same address.

```
for ii = 1:dataLength
    dataIn(ii) = randi([0 63],1,1,'uint8');
```

```

    wrAddr = fi((ii-1),0,4,0);
    writeEnable = true;
    dataOut(ii) = ram_2p(dataIn(ii),wrAddr,writeEnable,wrAddr);
end
dataOut

dataOut = 1x16 uint8 row vector

    0    0    0    0    0    0    0    0    0    0    0    0    0    0    0

```

Write and read from different addresses. The object returns the read result after one cycle delay.

```

for ii = 1:dataLength
    wrAddr = fi((ii-1),0,4,0);
    rdAddr = fi(dataLength-ii+1,0,4,0);
    writeEnable = true;
    dataOut(ii) = ram_2p(dataIn(ii),wrAddr,writeEnable,rdAddr);
end
dataOut

dataOut = 1x16 uint8 row vector

    0    9    9    51    31    61    62    10    61    61    35    17    6    40    58    8

```

Create Dual-Port RAM System Object

Construct System object to read from and write to different memory locations in RAM.

There are two output ports: a write output data port and a read output data port. The write output data port sends out the new data at the write address. The read output data port sends out the old data at the read address. The size of the RAM is inferred from the bitwidth of the address and write data on the first call to the object.

Note: This object syntax runs only in R2016b or later. If you are using an earlier release, replace each call of an object with the equivalent `step` syntax. For example, replace `myObject(x)` with `step(myObject,x)`.

```

ram_2p = hdl.RAM('RAMType','Dual port','WriteOutputValue','New data');
dataLength = 16;
[dataIn,wrDataOut,rdDataOut] = deal(uint8(zeros(1,dataLength)));

```

Write randomly generated data to the System object, and read the old data from the same address.

```

for ii = 1:dataLength
    dataIn(ii) = randi([0 63],1,1,'uint8');
    wrAddr = fi((ii-1),0,4,0);
    writeEnable = true;
    [wrDataOut(ii),rdDataOut(ii)] = ram_2p(dataIn(ii),wrAddr,writeEnable,wrAddr);
end
wrDataOut

wrDataOut = 1x16 uint8 row vector

```

```

    0  52  57  8  58  40  6  17  35  61  61  10  62  61  31  51

rdDataOut
rdDataOut = 1x16 uint8 row vector

    0  0  0  0  0  0  0  0  0  0  0  0  0  0  0  0

```

Write and read from different addresses. The object returns the read result after one cycle delay.

```

for ii = 1:dataLength
    wrAddr = fi((ii-1),0,4,0);
    rdAddr = fi(dataLength-ii+1,0,4,0);
    writeEnable = true;
    [wrDataOut(ii),rdDataOut(ii)] = ram_2p(dataIn(ii),wrAddr,writeEnable,rdAddr);
end
wrDataOut
wrDataOut = 1x16 uint8 row vector

    9  52  57  8  58  40  6  17  35  61  61  10  62  61  31  51

rdDataOut
rdDataOut = 1x16 uint8 row vector

    0  9  9  51  31  61  62  10  61  61  35  17  6  40  58  8

```

Create Dual-Port RAM with Multiple Banks

Create a System object that can write vector data to a dual-port RAM and read vector data out. Each element of the vector corresponds to a separate bank of RAM. This example creates 4 16-bit banks. Each bank has eight entries.

Note: This object syntax runs only in R2016b or later. If you are using an earlier release, replace each call of an object with the equivalent `step` syntax. For example, replace `myObject(x)` with `step(myObject,x)`.

Construct dual-port RAM System object.

```
ram_2p = hdl.RAM('RAMType','Dual port','WriteOutputValue','New data');
```

Create vector write data and addresses. Use a 3-bit address (for 8 locations), and write 16-bit data. Read and write addresses are independent. Allocate memory for the output data.

```
ramDataIn = fi(randi((2^16)-1,1,4),0,16,0);
ramReadAddr = fi([1,1,1,1],0,3,0);
ramWriteAddr = fi([1,1,1,1],0,3,0);
[wrOut,rdOut] = deal(fi(zeros(1,4),0,16,0));
```

First, write locations in bank 1 and 4, then read all banks. The write data is echoed in the `wrOut` output argument. The object returns read results after one cycle delay.

```
[wrOut,rdOut] = ram_2p(ramDataIn,ramWriteAddr,[true,false,false,true],ramReadAddr);
[wrOut,rdOut] = ram_2p(ramDataIn,ramWriteAddr,[false,false,false,false],ramReadAddr);
[wrOut,rdOut] = ram_2p(ramDataIn,ramWriteAddr,[false,false,false,false],ramReadAddr)
```

```
wrOut=1x4 object
    53393         0         0         59859

    DataTypeMode: Fixed-point: binary point scaling
    Signedness: Unsigned
    WordLength: 16
    FractionLength: 0
```

```
rdOut=1x4 object
    53393         0         0         59859

    DataTypeMode: Fixed-point: binary point scaling
    Signedness: Unsigned
    WordLength: 16
    FractionLength: 0
```

Algorithms

In your Simulink model, you can use the `hdl.RAM` inside a MATLAB System or a MATLAB Function block. If you log the output of a MATLAB System block, the output data has at least three dimensions because the MATLAB System block has at least two dimensions, and the time data adds a third dimension. For example, if you input scalar data to the block, the logged output data has the dimension $1 \times 1 \times N$, where N is the number of time steps. To obtain an output dimension that is same as the input dimension, add a Reshape block at the output with **Output dimensionality** set to Derive from reference input port.

RAM Inference with Scalar Data

If your data is scalar, the RAM size, or number of locations, is inferred from the data type of the address variable.

Data type of address variable	RAM address size (bits)
single or double	16
uint N	N
embedded.fi	WordLength

The maximum RAM address size is 32 bits.

RAM Inference with Vector Data

If your data is a vector, HDL Coder generates an array of parallel RAM banks. The number of elements in the vector determines the number of RAM banks. The size of each RAM bank is inferred from the data type of the address variable.

Data type of address variable	RAM address size (bits)
single or double	16

Data type of address variable	RAM address size (bits)
<code>uintN</code>	<i>N</i>
<code>embedded.fi</code>	<code>WordLength</code>

The maximum RAM bank address size is 32 bits.

Extended Capabilities

C/C++ Code Generation

Generate C and C++ code using MATLAB® Coder™.

HDL Code Generation

Generate Verilog and VHDL code for FPGA and ASIC designs using HDL Coder™.

Fixed-Point Conversion

Design and simulate fixed-point systems using Fixed-Point Designer™.

See Also

Blocks

Dual Port RAM | Dual Rate Dual Port RAM | Simple Dual Port RAM | Single Port RAM

Topics

“HDL Code Generation from hdl.RAM System Object”

“Getting Started with RAM and ROM in Simulink®”

“Implement RAM Using MATLAB Code”

“HDL Code Generation for System Objects”

Introduced in R2015a

coder.hdl.loopspec

Unroll or stream loops in generated HDL code

Syntax

```
coder.hdl.loopspec('unroll')
coder.hdl.loopspec('unroll',unroll_factor)
coder.hdl.loopspec('stream')
coder.hdl.loopspec('stream',stream_factor)
```

Description

`coder.hdl.loopspec('unroll')` fully unrolls a loop in the generated HDL code. Instead of a loop statement, the generated code contains multiple instances of the loop body, with one loop body instance per loop iteration.

The `coder.hdl.loopspec` pragma does not affect MATLAB simulation behavior.

Note If you specify the `coder.unroll` pragma, this pragma takes precedence over `coder.hdl.loopspec`. `coder.hdl.loopspec` has no effect.

`coder.hdl.loopspec('unroll',unroll_factor)` unrolls a loop by the specified unrolling factor, `unroll_factor`, in the generated HDL code.

The generated HDL code is a loop statement that contains `unroll_factor` instances of the original loop body. The number of loop iterations in the generated code is $(original_loop_iterations / unroll_factor)$. If $(original_loop_iterations / unroll_factor)$ has a remainder, the remaining iterations are fully unrolled as loop body instances outside the loop.

This pragma does not affect MATLAB simulation behavior.

`coder.hdl.loopspec('stream')` generates a single instance of the loop body in the HDL code. Instead of using a loop statement, the generated code implements local oversampling and added logic to match the functionality of the original loop.

You can specify this pragma for loops at the top level of your MATLAB design.

This pragma does not affect MATLAB simulation behavior.

`coder.hdl.loopspec('stream',stream_factor)` unrolls the loop with `unroll_factor` set to $original_loop_iterations / stream_factor$ rounded down to the nearest integer, and also oversamples the loop. If $(original_loop_iterations / stream_factor)$ has a remainder, the remainder loop body instances outside the loop are not oversampled, and run at the original rate.

You can specify this pragma for loops at the top level of your MATLAB design.

This pragma does not affect MATLAB simulation behavior.

Examples

Completely unroll MATLAB loop in generated HDL code

Unroll loop in generated code.

```
function y = hdltest
    pv = uint8(1);
    y = uint8(zeros(1,10));

    coder.hdl.loopspec('unroll');
    % Optional comment between pragma and loop statement
    for i = 1:10
        y(i) = pv + i;
    end
end
```

Partially unroll MATLAB loop in generated HDL code

Generate a loop statement in the HDL code that has two iterations and contains five instances of the original loop body.

```
function y = hdltest
    pv = uint8(1);
    y = uint8(zeros(1,10));

    coder.hdl.loopspec('unroll', 5);
    % Optional comment between pragma and loop statement
    for i = 1:10
        y(i) = pv + i;
    end
end
```

Completely stream MATLAB loop in generated HDL code

In the generated code, implement the 10-iteration MATLAB loop as a single instance of the original loop body that is oversampled by a factor of 10.

```
function y = hdltest
    pv = uint8(1);
    y = uint8(zeros(1,10));

    coder.hdl.loopspec('stream');
    % Optional comment between pragma and loop statement
    for i = 1:10
        y(i) = pv + i;
    end
end
```

Partially stream MATLAB loop in generated HDL code

In the generated code, implement the 10-iteration MATLAB loop as five instances of the original loop body that are oversampled by a factor of 2.

```
function y = hdltest
    pv = uint8(1);
    y = uint8(zeros(1,10));

    coder.hdl.loopspec('stream', 2);
    % Optional comment between pragma and loop statement
    for i = 1:10
        y(i) = pv + i;
    end
end
```

Input Arguments

stream_factor — Loop streaming factor

positive integer

Loop streaming factor, specified as a positive integer.

Setting `stream_factor` to the number of original loop iterations is equivalent to fully streaming the loop, or using `coder.hdl.loopspec('stream')`.

Example: 4

unroll_factor — Loop unrolling factor

positive integer

Number of loop body instances, specified as a positive integer.

Setting `unroll_factor` to the number of original loop iterations is equivalent to fully unrolling the loop, or using `coder.hdl.loopspec('unroll')`.

Example: 10

See Also

Topics

“Optimize MATLAB Loops”

Introduced in R2015a

coder.hdl.pipeline

Insert pipeline registers at output of MATLAB expression

Syntax

```
out = coder.hdl.pipeline(expr)
out = coder.hdl.pipeline(expr,num)
```

Description

`out = coder.hdl.pipeline(expr)` inserts one pipeline register at the output of `expr` in the generated HDL code. This pragma does not affect MATLAB simulation behavior.

Use this pragma to specify exactly where to insert pipeline registers. For example, in a MATLAB assignment statement, you can specify the `coder.hdl.pipeline` pragma:

- On the entire right side of the assignment statement.
- On a subexpression.
- By nesting multiple pragmas.
- On a call to a subfunction, if the subfunction returns a single value. You cannot specify the pragma for a subfunction that returns multiple values.

If you enable distributed pipelining, HDL Coder can move the pipeline registers to break the critical path.

HDL Coder cannot insert a pipeline register at the output of a MATLAB expression if any of the variables in the expression are:

- In a loop.
- A persistent variable that maps to a state element, like a state register or RAM.
- An output of a function. For example, in the following code, you cannot add a pipeline register for an expression containing `y`:

```
function [y] = myfun(x)
y = x + 5;
end
```

- In a data feedback loop. For example, in the following code, you cannot pipeline an expression containing the `t` or `pvar` variables:

```
persistent pvar;
t = u + pvar;
pvar = t + v;
```

You cannot use `coder.hdl.pipeline` to insert a pipeline register for a single variable or other no-op expression. To learn how to insert a pipeline register for a function input variable, see “Port Registers”.

`out = coder.hdl.pipeline(expr,num)` inserts `num` pipeline registers at the output of `expr` in the generated HDL code. This pragma does not affect MATLAB simulation behavior.

Use this pragma to specify exactly where to insert pipeline registers. For example, in a MATLAB assignment statement, you can specify the `coder.hdl.pipeline` pragma:

- On the entire right side of the assignment statement.
- On a subexpression.
- By nesting multiple pragmas.
- On a call to a subfunction, if the subfunction returns a single value. You cannot specify the pragma for a subfunction that returns multiple values.

If you enable distributed pipelining, HDL Coder can move the pipeline registers to break the critical path.

HDL Coder cannot insert a pipeline register at the output of a MATLAB expression if any of the variables in the expression are:

- In a loop.
- A persistent variable that maps to a state element, like a state register or RAM.
- An output of a function. For example, in the following code, you cannot add a pipeline register for an expression containing `y`:

```
function [y] = myfun(x)
y = x + 5;
end
```

- In a data feedback loop. For example, in the following code, you cannot pipeline an expression containing the `t` or `pvar` variables:

```
persistent pvar;
t = u + pvar;
pvar = t + v;
```

You cannot use `coder.hdl.pipeline` to insert a pipeline register for a single variable or other no-op expression. To learn how to insert a pipeline register for a function input variable, see “Port Registers”.

Examples

Insert one pipeline register at output of MATLAB expression

At the output of a MATLAB expression, `a + b * c`, insert a single pipeline register.

```
y = coder.hdl.pipeline(a + b * c);
```

Insert multiple pipeline registers at output of MATLAB expression

At the output of a MATLAB expression, `a + b * c`, insert three pipeline registers.

```
y = coder.hdl.pipeline(a + b * c, 3);
```

Insert pipeline registers at intermediate stage of MATLAB expression

For a MATLAB expression, $a + b * c$, after the computation of $b * c$, insert five pipeline registers.

```
y = a + coder.hdl.pipeline(b * c, 5);
```

Insert pipeline registers at intermediate stage and at output of MATLAB expression

At an intermediate stage and at the output of a MATLAB expression, use nested `coder.hdl.pipeline` pragmas to insert pipeline registers.

For a MATLAB expression, $a + b * c$, after the computation of $b * c$, insert five pipeline registers, and insert two pipeline registers at the output of the whole expression.

```
y = coder.hdl.pipeline(a + coder.hdl.pipeline(b * c, 5),2);
```

Input Arguments

expr — MATLAB expression to pipeline

MATLAB expression

MATLAB expression to pipeline. At the output of this expression in the generated HDL code, insert pipeline registers.

Example: $a + b$

num — Number of registers

MATLAB expression

Number of pipeline registers to insert at the output of `expr` in the generated HDL code, specified as a positive integer.

Example: 3

See Also

Topics

“Pipeline MATLAB Expressions”

“Pipelining MATLAB Code”

Introduced in R2015a

hdlcoder.Board class

Package: hdlcoder

Board registration object that describes SoC custom board

Description

`board = hdlcoder.Board` creates a board object that you use to register a custom board for an SoC platform.

To specify the characteristics of your board, set the properties of the board object.

Construction

`board = hdlcoder.Board` creates an `hdlcoder.Board` object that you can use to register a custom board for an SoC platform.

Properties

BoardName — Board name

'' (default) | character vector

Board name, specified as a character vector. In the HDL Workflow Advisor, this name appears in the **Target platform** dropdown list.

Example: 'Enclustra Mars ZX3 with PM3 base board'

FPGAVendor — Vendor name

'' (default) | 'Altera' | 'Xilinx'

FPGA vendor name, specified as a character vector.

Example: 'Xilinx'

FPGAFamily — FPGA family name

'' (default) | character vector

FPGA family name, specified as a character vector.

Example: 'Zynq'

FPGADevice — FPGA device identifier

'' (default) | character vector

FPGA device identifier, specified as a character vector.

Example: 'xc7z020'

FPGAPackage — FPGA package identifier for Xilinx devices

'' (default) | character vector

FPGA package identifier for Xilinx devices, specified as a character vector.

For Altera devices, this property is ignored.

Example: 'c1g484'

FPGASpeed — FPGA speed for Xilinx devices

' ' (default) | character vector

FPGA speed for Xilinx devices, specified as a character vector.

For Altera devices, this property is ignored.

Example: '-1'

SupportedTool — Supported synthesis tool

' ' (default) | cell array of character vectors

Synthesis tool or tools that support this board, specified as a cell array of character vectors. In the HDL Workflow Advisor, the **Synthesis tool** dropdown list shows the values in this cell array.

Example: {'Altera Quartus II'}

Example: {'Xilinx Vivado'}

Example: {'Xilinx Vivado','Xilinx ISE'}

JTAGChainPosition — Optional JTAG chain position number

2 (default) | positive integer

JTAG chain position number, specified as a positive integer. The JTAG chain position number is used when programming the FPGA via JTAG.

This property is optional.

Example: 3

Methods

<code>addExternalIOInterface</code>	Define external IO interface for board object
<code>addExternalPortInterface</code>	Define external port interface for board object
<code>validateBoard</code>	Check property values in board object

See Also

`hdlcoder.ReferenceDesign`

Topics

“Define Custom Board and Reference Design for Zynq Workflow”

“Define Custom Board and Reference Design for Intel SoC Workflow”

“Register a Custom Board”

“Register a Custom Reference Design”

“Board and Reference Design Registration System”

Introduced in R2015a

addExternalIOInterface

Class: hdlcoder.Board

Package: hdlcoder

Define external IO interface for board object

Syntax

```
addExternalIOInterface('InterfaceID',interfacename,'InterfaceType',
interfacetype,'PortName',portname,'PortWidth',portwidth,'FPGAPin',
pins,'IOPadConstraint',constraints)
```

Description

addExternalIOInterface('InterfaceID',interfacename,'InterfaceType',interfacetype,'PortName',portname,'PortWidth',portwidth,'FPGAPin',pins,'IOPadConstraint',constraints) adds an external IO interface to an hdlcoder.Board object. You can add multiple external IO interfaces to your board object.

Use this method if your board has more than one external interface, or if you want to be able to predefine FPGA pin names for mapping from the HDL Workflow Advisor.

Input Arguments

interfacename — Interface name

character vector

Interface name, specified as a character vector. In the HDL Workflow Advisor, this name appears in the **Target Platform Interfaces** dropdown list.

Example: 'LEDs General Purpose'

interfacetype — Interface direction

'IN' | 'OUT'

Interface direction, specified as a character vector. In the HDL Workflow Advisor, when you specify a target interface for each of your DUT ports, this external IO interface is available only for ports with a matching direction.

For example, if you set interfacetype to 'OUT', this external IO interface is available only for Output DUT ports.

Example: 'OUT'

portname — Port name

character vector

Board top-level port name, specified as a character vector.

Example: 'GPLEDs'

portwidth — Port bit width

positive integer

Port bit width, specified as a positive integer.

Example: 4

pins — Pin names

cell array of character vectors

FPGA pin names, specified as a cell array of character vectors.

Example: { 'H18' , 'AA14' , 'AA13' , 'AB15' }

constraints — IO pad constraints

{ } (default) | cell array of character vectors

IO pad constraints, specified as a cell array of character vectors.

Example: { 'IOSTANDARD = LVCMOS25' }

Example: { 'IOSTANDARD = LVCMOS25' , 'SLEW = SLOW' }

Tips

- For details about the external IO interface ports, pins, and constraints for your board, view the board documentation.

See Also

addExternalPortInterface | hdlcoder.Board

Topics

“Define Custom Board and Reference Design for Zynq Workflow”

“Define Custom Board and Reference Design for Intel SoC Workflow”

“Register a Custom Board”

“Board and Reference Design Registration System”

Introduced in R2015a

addExternalPortInterface

Class: hdlcoder.Board

Package: hdlcoder

Define external port interface for board object

Syntax

```
addExternalPortInterface('IOPadConstraint', constraints)
```

Description

`addExternalPortInterface('IOPadConstraint', constraints)` adds a generic external port interface to an `hdlcoder.Board` object. You can add at most one external port interface to your board object.

Use this method if you want the **External Port** option to be available in the HDL Workflow Advisor **Target Platform Interface** dropdown list. If you use this method to add an external port, in the HDL Workflow Advisor, you must manually specify pin names in the **Bit Range / Address / FPGA Pin** field.

Input Arguments

constraints — IO pad constraints

{ } (default) | cell array of character vectors

IO pad constraints, specified as a cell array of character vectors.

Example: { 'IOSTANDARD = LVCMOS25' }

Example: { 'IOSTANDARD = LVCMOS25', 'SLEW = SLOW' }

Tips

- To get IO constraint names for your board, view the board documentation.

Alternatives

If you know the details of the external interface, and want to make them available as UI dropdown list options in the HDL Workflow advisor, use the `addExternalIOInterface` method instead. For example, using `hdlcoder.Board.addExternalIOInterface`, you can predefine characteristics of the interface such as the name, port bit width, signal direction, and valid pin names.

See Also

`addExternalIOInterface` | `hdlcoder.Board`

Topics

“Define Custom Board and Reference Design for Zynq Workflow”

“Define Custom Board and Reference Design for Intel SoC Workflow”

“Register a Custom Board”
“Board and Reference Design Registration System”

Introduced in R2015a

validateBoard

Class: hdlcoder.Board

Package: hdlcoder

Check property values in board object

Syntax

```
validateBoard
```

Description

validateBoard checks that the hdlcoder.Board object has nondefault values for all required properties, and that property values have valid data types. This method does not check the correctness of property values for the target board. If validation fails, the software displays an error message.

See Also

hdlcoder.Board

Topics

“Define Custom Board and Reference Design for Zynq Workflow”

“Define Custom Board and Reference Design for Intel SoC Workflow”

“Register a Custom Board”

“Board and Reference Design Registration System”

Introduced in R2015a

hdlcoder.ReferenceDesign class

Package: hdlcoder

Reference design registration object that describes SoC reference design

Description

`refdesign = hdlcoder.ReferenceDesign('SynthesisTool', toolname)` creates a reference design object that you use to register a custom reference design for an SoC platform.

To specify the characteristics of your reference design, set the properties of the reference design object.

Use a reference design tool version that is compatible with the supported tool version. If you choose a different tool version, it is possible that HDL Coder is unable to create the reference design project for IP core integration.

Construction

`refdesign = hdlcoder.ReferenceDesign('SynthesisTool', toolname)` creates a reference design object that you use to register a custom reference design for an SoC platform.

Input Arguments

toolname — Synthesis tool name

Xilinx Vivado (default) | Altera Quartus II | Xilinx ISE | Xilinx Vivado

Synthesis tool name, specified as a character vector.

Example: 'Altera Quartus II'

Properties

ReferenceDesignName — Reference design name

' ' (default) | character vector

Reference design name, specified as a character vector. In the HDL Workflow Advisor, this name appears in the **Reference design** dropdown list.

Example: 'Default system (Vivado 2015.4)'

BoardName — Board name

' ' (default) | character vector

Board associated with this reference design, specified as a character vector.

Example: 'Enclustra Mars ZX3 with PM3 base board'

SupportedToolVersion — Supported tool version

{ } (default) | cell array of character vectors

One or more tool versions that work with this reference design, specified as a cell array of character vectors.

Example: {'2015.4'}

Example: {'13.7', '14.0'}

CustomConstraints — Design constraint file (optional)

{ } (default) | cell array of character vectors

One or more design constraint files, specified as a cell array of character vectors. This property is optional.

Example: {'MarsZX3_PM3.xdc'}

Example: {'MyDesign.qsf'}

CustomFiles — Relative path to required file or folder (optional)

{ } (default) | cell array of character vectors

One or more relative paths to files or folders that the reference design requires, specified as a cell array of character vectors. This property is optional.

Examples of required files or folders:

- Existing IP core used in the reference design.

For example, if the IP core, *my_ip_core*, is in the reference design folder, set `CustomFiles` to {'*my_ip_core*'}

- PS7 definition XML file.

For example, to include a PS7 definition XML file, *ps7_system_prj.xml*, in a folder, *data*, set `CustomFiles` to {`fullfile('data', 'ps7_system_prj.xml')`}

- Folder containing existing IP cores used in the reference design. HDL Coder only supports a specific IP core folder name for each synthesis tool:
 - For Altera Qsys, IP core files must be in a folder named `ip`. Set `CustomFiles` to {'`ip`'}.
 - For Xilinx Vivado, IP core files, or a zip file containing the IP core files, must be in a folder named `ipcore`. Set `CustomFiles` to {'`ipcore`'}.
 - For Xilinx EDK, IP core files must be in a folder named `pcores`. Set `CustomFiles` to {'`pcores`'}.

Note To add IP modules to the reference design, it is recommended to create an IP repository folder that contains these IP modules, and then use the `addIPRepository` method.

Example: {'my_ip_core'}

Example: {`fullfile('data', 'ps7_system_prj.xml')`}

Example: {'ip'}

Example: {'ipcore'}

Example: {'pcores'}

AddJTAGMATLABasAXIMasterParameterValue — Control visibility of JTAG as AXI Master IP`'true'` (default) | `'false'` | character vector

Specify whether you want the parameter **Insert JTAG MATLAB as AXI Master (HDL Verifier Required)** to be displayed in the **Set Target Reference Design** task of the HDL Workflow Advisor. By default, this property value is set to `true`, and the parameter is displayed in the **Set Target Reference Design** task. After you enable this property, to specify whether you want the code generator to insert the JTAG MATLAB as AXI Master IP, use the `JTAGMATLABasAXIMasterDefaultValue` property. If you do not want the parameter to be displayed, set the property value to `false`.

This property is optional.

Example: `'false'`

JTAGMATLABasAXIMasterDefaultValue — Specify whether to insert MATLAB as AXI Master IP`'off'` (default) | `'on'` | character vector

Specify whether you want the code generator to insert the JTAG MATLAB as AXI Master IP. The values that you specify are the choices for the **Insert JTAG MATLAB as AXI Master (HDL Verifier Required)** dropdown in the **Set Target Reference Design** task of the HDL Workflow Advisor. To specify insertion of the JTAG as AXI Master automatically, before you set this property to `on`, set the `AddJTAGMATLABasAXIMasterParameterValue` property to `true`.

This property is optional.

Example: `'on'`

IPCacheZipFile — IP cache file to include in the project`''` (default) | `'ipcache.zip'` | character vector

Specify the IP cache zip file to include in your project. When you run the IP Core Generation workflow in the HDL Workflow Advisor, the code generator extracts this file in the **Create Project** task. The **Build FPGA Bitstream** task reuses the IP cache, which accelerates reference design synthesis.

This property is optional.

Example: `'ipcache.zip'`

ReportTimingFailure — Report timing failures as warnings or errors`'hdlcoder.ReportTiming.Warning'` (default) | `'hdlcoder.ReportTiming.Error'`

Specify whether you want the code generator to report timing failures in the **Build FPGA Bitstream** task as warnings or errors. When you run the IP Core Generation workflow in the HDL Workflow Advisor, by default, the code generator reports any timing failures as error. If you have implemented the custom logic to resolve timing failures, you can specify these failures to be reported as warning instead of error. To learn more, see “Resolve Timing Failures in IP Core Generation and Simulink Real-Time FPGA I/O Workflows”.

This property is optional.

Example: `'hdlcoder.ReportTiming.Warning'`

Methods

<code>addAXI4MasterInterface</code>	Add and define AXI4 Master interface
<code>addAXI4SlaveInterface</code>	Add and define AXI4 slave interface
<code>addAXI4StreamInterface</code>	Add AXI4-Stream interface
<code>addAXI4StreamVideoInterface</code>	Add AXI4-Stream Video interface
<code>addInternalIOInterface</code>	Add and define internal IO interface between generated IP core and existing IP cores
<code>addClockInterface</code>	Add clock and reset interface
<code>addCustomEDKDesign</code>	Specify Xilinx EDK MHS project file
<code>addCustomQsysDesign</code>	Specify Altera Qsys project file
<code>addCustomVivadoDesign</code>	Specify Xilinx Vivado exported block design Tcl file
<code>addIPRepository</code>	Include IP modules from your IP repository folder in your custom reference design
<code>addParameter</code>	Add and define custom parameters for your reference design
<code>CallbackCustomProgrammingMethod</code>	Function handle for custom callback function that gets executed during Program Target Device task in the Workflow Advisor
<code>CustomizeReferenceDesignFcn</code>	Function handle for callback function that gets executed before Set Target Interface task in the HDL Workflow Advisor
<code>EmbeddedCoderSupportPackage</code>	Specify whether to use an Embedded Coder support package
<code>PostBuildBitstreamFcn</code>	Function handle for callback function that gets executed after Build FPGA Bitstream task in the HDL Workflow Advisor
<code>PostCreateProjectFcn</code>	Function handle for callback function that gets executed after Create Project task in the HDL Workflow Advisor
<code>PostSWInterfaceFcn</code>	Function handle for custom callback function that gets executed after Generate Software Interface Model task in the HDL Workflow Advisor
<code>PostTargetInterfaceFcn</code>	Function handle for callback function that gets executed after Set Target Interface task in the HDL Workflow Advisor
<code>PostTargetReferenceDesignFcn</code>	Function handle for callback function that gets executed after Set Target Reference Design task in the HDL Workflow Advisor
<code>validateReferenceDesign</code>	Check property values in reference design object

See Also

`hdlcoder.Board`

Topics

“Define Custom Board and Reference Design for Zynq Workflow”

“Define Custom Board and Reference Design for Intel SoC Workflow”

“Register a Custom Board”

“Register a Custom Reference Design”

“Define Custom Parameters and Callback Functions for Custom Reference Design”

“Board and Reference Design Registration System”

Introduced in R2015a

addAXI4MasterInterface

Class: hdlcoder.ReferenceDesign

Package: hdlcoder

Add and define AXI4 Master interface

Syntax

```
addAXI4MasterInterface(InterfaceConnection',Interface_Connection)
addAXI4MasterInterface(InterfaceConnection',
Interface_Connection,'TargetAddressSegments',Target_Address_Segments)
addAXI4MasterInterface(InterfaceConnection',Interface_Connection, Name,Value)
addAXI4MasterInterface(InterfaceConnection',
Interface_Connection,'TargetAddressSegments',Target_Address_Segments,
Name,Value)
```

Description

`addAXI4MasterInterface(InterfaceConnection',Interface_Connection)` adds and defines an AXI4 Master interface for an Intel Qsys reference design.

`addAXI4MasterInterface(InterfaceConnection',Interface_Connection,'TargetAddressSegments',Target_Address_Segments)` adds and defines an AXI4 Master interface for a Xilinx Vivado reference design.

`addAXI4MasterInterface(InterfaceConnection',Interface_Connection, Name,Value)` adds and defines an AXI4 Master interface for an Intel Qsys reference design, with additional options specified by one or more `Name, Value` pair arguments.

`addAXI4MasterInterface(InterfaceConnection',Interface_Connection,'TargetAddressSegments',Target_Address_Segments, Name,Value)` adds and defines an AXI4 Master interface for a Xilinx Vivado reference design, with additional options specified by one or more `Name, Value` pair arguments.

Input Arguments

Interface_Connection — Reference design port name

' ' (default) | character vector

Name of the reference design port that is connected to the AXI4 Master interface, specified as a character vector.

Example: 'axi_interconnect_1/S01_AXI'

Target_Address_Segments — Reference design address segments

' ' (default) | character vector

Target address segment of the Xilinx Vivado reference design, specified as a character vector. The format of the target address segment is {'SegmentName', low address, range}. You must use a power of 2 value for range.

```
Example: '{{'mig_7series_0/memmap/  
memaddr',hex2dec('40000000'),hex2dec('40000000')}}'
```

Tip To add more than one AXI4 Master interface to your reference design, call the `addAXI4MasterInterface` method multiple times depending on the number of interfaces you want to add. For each additional interface, specify a unique `InterfaceID`.

Name-Value Pair Arguments

Specify optional comma-separated pairs of `Name`, `Value` arguments. `Name` is the argument name and `Value` is the corresponding value. `Name` must appear inside quotes. You can specify several name and value pair arguments in any order as `Name1, Value1, . . . , NameN, ValueN`.

InterfaceID — AXI4 Master interface name

'AXI4 Master' (default) | character vector

Name of the AXI4 Master interface that you add to the reference design, specified as a character vector. If you create multiple AXI4 Master interfaces, make sure that you use unique names for each interface.

Example: 'AXI4 Master 1'

ReadSupport — AXI4 Master read interface support

'true' (default) | 'false'

Specify whether you want the AXI4 Master interface to support a read channel as a `Boolean`.

Example: 'ReadSupport', 'true' specifies support for an AXI4 Master read interface connection.

WriteSupport — AXI4 Master write interface support

'true' (default) | 'false'

Specify whether you want the AXI4 Master interface to support a write channel as a `Boolean`.

Example: 'WriteSupport', 'true' specifies support for an AXI4 Master write interface connection.

MaxDataWidth — Maximum data width

128 (default) | Integer

Maximum width for the `Data` signal that is transferred across the AXI4 Master interface, specified as an integer.

Example: 'MaxDataWidth', 32 specifies maximum data width of 32 bits.

AddrWidth — Address width

32 (default) | Integer

Width of the AXI4 Master interface read and write addresses, specified as an integer.

Example: 'AddrWidth', 32 specifies an address size of 32 bits.

DefaultReadBaseAddr — Starting read address

0 (default) | Integer

Default starting address of the AXI4 Master read interface, specified as an integer.

Example: 'DefaultReadBaseAddr', hex2dec('40000000') specifies hex2dec('40000000') as the starting read address.

DefaultWriteBaseAddr — Starting write address

0 (default) | Integer

Default starting address of the AXI4 Master write interface, specified as an integer.

Example: 'DefaultReadBaseAddr', hex2dec('41000000') specifies hex2dec('41000000') as the starting write address.

See Also

[addAXI4StreamInterface](#) | [addClockInterface](#) | [hdlcoder.ReferenceDesign](#)

Topics

[“Performing Large Matrix Operation on FPGA using External Memory”](#)

[“Define Custom Board and Reference Design for Zynq Workflow”](#)

[“Define Custom Board and Reference Design for Intel SoC Workflow”](#)

[“Model Design for AXI4 Master Interface Generation”](#)

[“Register a Custom Board”](#)

[“Register a Custom Reference Design”](#)

[“Board and Reference Design Registration System”](#)

Introduced in R2017b

addAXI4SlaveInterface

Class: hdlcoder.ReferenceDesign

Package: hdlcoder

Add and define AXI4 slave interface

Syntax

```
addAXI4SlaveInterface('InterfaceConnection',ref_design_port,'BaseAddress',
base_addr)
addAXI4SlaveInterface('InterfaceConnection',ref_design_port,'BaseAddress',
base_addr,'MasterAddressSpace',master_addr_space)
addAXI4SlaveInterface('InterfaceConnection',ref_design_port,'BaseAddress',
base_addr,Name,Value)
addAXI4SlaveInterface('InterfaceConnection',ref_design_port,'BaseAddress',
base_addr,'MasterAddressSpace',master_addr_space,Name,Value)
```

Description

`addAXI4SlaveInterface('InterfaceConnection',ref_design_port,'BaseAddress',base_addr)` adds and defines an AXI4 interface for an Altera reference design, or an AXI4 or AXI4-Lite interface for a Xilinx ISE reference design.

`addAXI4SlaveInterface('InterfaceConnection',ref_design_port,'BaseAddress',base_addr,'MasterAddressSpace',master_addr_space)` adds and defines an AXI4 or AXI4-Lite interface for Xilinx Vivado reference designs.

`addAXI4SlaveInterface('InterfaceConnection',ref_design_port,'BaseAddress',base_addr,Name,Value)` adds and defines an AXI4 interface for an Altera reference design, or an AXI4 or AXI4-Lite interface for a Xilinx ISE reference design, with additional options specified by one or more `Name, Value` pair arguments.

`addAXI4SlaveInterface('InterfaceConnection',ref_design_port,'BaseAddress',base_addr,'MasterAddressSpace',master_addr_space,Name,Value)` adds and defines an AXI4 or AXI4-Lite interface for Xilinx Vivado reference designs, with additional options specified by one or more `Name, Value` pair arguments.

Input Arguments

ref_design_port — Reference design port name

' ' (default) | character vector

Reference design port that is connected to the AXI4 or AXI4-Lite interface, specified as a character vector. For reference designs based on Intel Qsys, when you want to connect multiple AXI Master IPs to the AXI4 or AXI4-Lite interface, specify each of the AXI Master instance names and the corresponding port names as a cell array of character vectors.

Example: `'axi_interconnect_0/M00_AXI'`,
`{'hps_0.h2f_axi_master','master_0.master'},...`

base_addr — Base address

'' (default) | character vector

Base address for AXI4 or AXI4-Lite slave interface, specified as a character vector.

Example: '0x40010000'

master_addr_space — Master interface address space (Vivado only)

'' (default) | character vector

Address space of the master interface connected to this slave interface, specified as a character vector. For Vivado reference designs only. When you want to connect more than one AXI Master IP, specify each of the AXI Master instance names and the corresponding address spaces.

Example: 'processing_system7_0/Data', {'processing_system7_0/Data', 'hdlverifier_axi_master_0/axi4m'}

Name-Value Pair Arguments

Specify optional comma-separated pairs of *Name*, *Value* arguments. *Name* is the argument name and *Value* is the corresponding value. *Name* must appear inside quotes. You can specify several name and value pair arguments in any order as *Name1*, *Value1*, . . . , *NameN*, *ValueN*.

InterfaceType — Interface type

{'AXI4-Lite', 'AXI4'} (default) | 'AXI4' | 'AXI4-Lite'

Type of interface connection, specified as a character vector or a cell array of character vectors.

Example: 'InterfaceType', 'AXI4-Lite' specifies an 'AXI4-Lite' interface type connection.

InterfaceID — Interface name

{'AXI4-Lite', 'AXI4'} (default) | character vector

Name of the interface, specified as a character vector. When you provide the *InterfaceID*, *InterfaceType* must be set to either 'AXI4' or 'AXI4-Lite'.

Example: 'InterfaceID', 'MyAXI4', 'InterfaceType', 'AXI4' specifies interface name as 'MyAXI4' and interface type as 'AXI4'.

IDWidth — Width of ID signals

12 (default) | positive integer

Width of all ID signals, such as *AWID*, *WID*, *ARID*, and *RID*, specified as a positive integer. This property enables you to specify the number of AXI Master interfaces that you want the AXI4 slave interface in the HDL DUT IP core to connect to. The default value is 12, which enables you to connect the HDL IP core to one AXI Master interface. To connect the IP core to multiple AXI Master interfaces, increase the *IDWidth*. The ID width is tool-specific.

Example: 'IDWidth', '13' may indicate that you want the IP core to connect to two AXI Master interfaces in the reference design.

Tips

- Before running this method, you must run the `addClockInterface` method.

- The `addAXI4SlaveInterface` method is optional. You can define your own custom reference design without the AXI4 slave interface.
- To connect the HDL IP core for your DUT to multiple AXI Master interfaces in the reference design, use the `IDWidth` property of this method. To learn more, see “Define Multiple AXI Master Interfaces in Reference Designs to access DUT AXI4 Slave Interface”.

See Also

`addClockInterface` | `hdlcoder.ReferenceDesign`

Topics

“Define Custom Board and Reference Design for Zynq Workflow”

“Define Custom Board and Reference Design for Intel SoC Workflow”

“Register a Custom Board”

“Register a Custom Reference Design”

“Define Multiple AXI Master Interfaces in Reference Designs to access DUT AXI4 Slave Interface”

“Board and Reference Design Registration System”

Introduced in R2015a

addAXI4StreamInterface

Class: hdlcoder.ReferenceDesign

Package: hdlcoder

Add AXI4-Stream interface

Syntax

```
addAXI4StreamInterface('MasterChannelConnection',
Master_Channel_Port,'SlaveChannelConnection',Slave_Channel_Port)
addAXI4StreamInterface('MasterChannelConnection',
Master_Channel_Port,'SlaveChannelConnection',Slave_Channel_Port), Name,Value
```

Description

addAXI4StreamInterface('MasterChannelConnection', Master_Channel_Port,'SlaveChannelConnection',Slave_Channel_Port) adds an AXI4-Stream interface to an hdlcoder.ReferenceDesign object.

addAXI4StreamInterface('MasterChannelConnection', Master_Channel_Port,'SlaveChannelConnection',Slave_Channel_Port), Name,Value adds and defines an AXI4-Stream interface, with additional options specified by one or more Name,Value pair arguments.

Input Arguments

Master_Channel_Port — Reference design port connected to IP core AXI4-Stream master interface

character vector

Reference design port connected to the IP core AXI4-Stream master interface, specified as a character vector. This port should be an AXI4-Stream slave interface. If master_channel_enable is true, you must specify master_channel_port.

Example: 'axi_dma_0/S_AXIS_S2MM'

Slave_Channel_Port — Reference design port connected to IP core AXI4-Stream slave interface

character vector

Reference design port connected to the IP core AXI4-Stream slave interface, specified as a character vector. This port should be an AXI4-Stream master interface. If slave_channel_number is true, you must specify slave_channel_port and slave_channel_data_width.

Example: 'axi_dma_0/M_AXIS_MM2S'

Tip To add more than one AXI4-Stream interface to your reference design, call the addAXI4StreamInterface method multiple times depending on the number of interfaces you want to add. For each additional interface, specify a unique InterfaceID.

Name-Value Pair Arguments

Specify optional comma-separated pairs of `Name`, `Value` arguments. `Name` is the argument name and `Value` is the corresponding value. `Name` must appear inside quotes. You can specify several name and value pair arguments in any order as `Name1, Value1, . . . , NameN, ValueN`.

InterfaceID — AXI4-Stream interface name

'AXI4-Stream' (default) | character vector

Name of the AXI4-Stream interface that you add to the reference design, specified as a character vector. To create multiple AXI4-Stream interfaces, make sure that you use unique names for each interface.

Example: 'AXI4-Stream1', 'AXI4-Stream2'

MasterChannelEnable — Master channel enable signal

'true' (default) | 'false'

Master channel enable signal, specified as either `true` or `false`. By default, `MasterChannelEnable` is `true`, and you must specify `master_channel_port`. To use a reference design that has only a Slave channel, set `MasterChannelEnable` to `false` and do not specify the `master_channel_port`.

Example: 'false'

SlaveChannelEnable — Slave channel enable

'true' (default) | 'false'

Slave channel enable signal, specified as either `true` or `false`. By default, `SlaveChannelEnable` is `true`, and you must specify `slave_channel_port`. To use a reference design that has only a Master channel, set `SlaveChannelEnable` to `false` and do not specify the `slave_channel_port`.

Example: 'false'

MasterChannelDataWidth — Master channel data width

32 (default) | positive integer

Reference design master channel TDATA bit width, specified as a positive integer. By default, the `master_channel_data_width` is 32 bits.

Example: 32

SlaveChannelDataWidth — Slave channel data width

32 (default) | positive integer

Reference design slave channel TDATA bit width, specified as a positive integer. By default, `slave_channel_data_width` is 32 bits.

Example: 32

See Also

`hdlcoder.ReferenceDesign`

Topics

“Getting Started with AXI4-Stream Interface in Zynq Workflow”

Define and Register Custom Board and Reference Design for SoC Workflow

“Model Design for AXI4-Stream Interface Generation”
“Register a Custom Board”
“Register a Custom Reference Design”
“Board and Reference Design Registration System”

Introduced in R2020a

addAXI4StreamVideoInterface

Class: hdlcoder.ReferenceDesign

Package: hdlcoder

Add AXI4-Stream Video interface

Syntax

```
addAXI4StreamVideoInterface('MasterChannelConnection',  
Master_Channel_Port,'SlaveChannelConnection',Slave_Channel_Port)  
addAXI4StreamVideoInterface('MasterChannelConnection',  
Master_Channel_Port,'SlaveChannelConnection',Slave_Channel_Port), Name,Value
```

Description

`addAXI4StreamVideoInterface('MasterChannelConnection', Master_Channel_Port, 'SlaveChannelConnection', Slave_Channel_Port)` adds an AXI4-Stream Video interface to an `hdlcoder.ReferenceDesign` object.

`addAXI4StreamVideoInterface('MasterChannelConnection', Master_Channel_Port, 'SlaveChannelConnection', Slave_Channel_Port), Name, Value` adds and defines an AXI4-Stream Video interface, with additional options specified by one or more `Name, Value` pair arguments.

Input Arguments

Master_Channel_Port — Reference design port connected to IP core AXI4-Stream Video master interface

character vector

Reference design port connected to the IP core AXI4-Stream Video master interface, specified as a character vector. This port should be an AXI4-Stream Video slave interface. If `master_channel_enable` is `true`, you must specify `master_channel_port`.

Example: 'RGBtoYCbCr_0/AXI4_Stream_Video_Slave'

Slave_Channel_Port — Reference design port connected to IP core AXI4-Stream Video slave interface

character vector

Reference design port connected to the IP core AXI4-Stream Video slave interface, specified as a character vector. This port should be an AXI4-Stream Video master interface. If `slave_channel_number` is `true`, you must specify `slave_channel_port`.

Example: 'YCbCrtoRGB_0/AXI4_Stream_Video_Master'

Tip To add more than one AXI4-Stream Video interface to your reference design, call the `addAXI4StreamVideoInterface` method multiple times depending on the number of interfaces you want to add. For each additional interface, specify a unique `InterfaceID`.

Name-Value Pair Arguments

Specify optional comma-separated pairs of `Name`, `Value` arguments. `Name` is the argument name and `Value` is the corresponding value. `Name` must appear inside quotes. You can specify several name and value pair arguments in any order as `Name1, Value1, . . . , NameN, ValueN`.

InterfaceID — AXI4-Stream Video interface name

'AXI4-Stream Video' (default) | character vector

Name of the AXI4-Stream Video interface that you add to the reference design, specified as a character vector. To create multiple AXI4-Stream Video interfaces, make sure that you use unique names for each interface.

Example: 'AXI4-Stream Video1','AXI4-Stream Video2'

MasterChannelEnable — Master channel enable signal

'true' (default) | 'false'

Master channel enable signal, specified as either `true` or `false`. By default, `MasterChannelEnable` is `true`, and you must specify `master_channel_port`. To use a reference design that has only a Slave channel, set `MasterChannelEnable` to `false` and do not specify the `master_channel_port`.

Example: 'false'

SlaveChannelEnable — Slave channel enable

'true' (default) | 'false'

Slave channel enable signal, specified as either `true` or `false`. By default, `SlaveChannelEnable` is `true`, and you must specify `slave_channel_port`. To use a reference design that has only a Master channel, set `SlaveChannelEnable` to `false` and do not specify the `slave_channel_port`.

Example: 'false'

MasterChannelDataWidth — Master channel data width

32 (default) | positive integer

Reference design master channel TDATA bit width, specified as a positive integer. By default, the `master_channel_data_width` is 32 bits.

Example: 32

SlaveChannelDataWidth — Slave channel data width

32 (default) | positive integer

Reference design slave channel TDATA bit width, specified as a positive integer. By default, `slave_channel_data_width` is 32 bits.

Example: 32

See Also

`hdlcoder.ReferenceDesign`

Topics

“Getting Started with AXI4-Stream Video Interface in Zynq Workflow”

Define and Register Custom Board and Reference Design for SoC Workflow

“Model Design for AXI4-Stream Video Interface Generation”
“Register a Custom Board”
“Register a Custom Reference Design”
“Board and Reference Design Registration System”

Introduced in R2020a

addInternalIOInterface

Class: hdlcoder.ReferenceDesign

Package: hdlcoder

Add and define internal IO interface between generated IP core and existing IP cores

Syntax

```
addInternalIOInterface('InterfaceID',interface_name,'InterfaceType',
interface_type,'PortName',port_name,'PortWidth',
port_width,'InterfaceConnection',interface_connection)
```

Description

addInternalIOInterface('InterfaceID',interface_name,'InterfaceType',interface_type,'PortName',port_name,'PortWidth',port_width,'InterfaceConnection',interface_connection) adds and defines an internal IO interface between the generated IP core and other IP cores in the reference design.

In the HDL Workflow Advisor, if you target a custom reference design that has an internal IO interface, you must map a DUT port to the internal IO interface. In the Target Platform Interface Table, you cannot leave the internal IO interface unassigned.

Input Arguments

interface_name — Custom internal IO interface name

' ' (default) | character vector

Custom internal IO interface name, specified as a character vector. In the HDL Workflow Advisor, when you select the custom reference design, this name appears as an option in the Target Platform Interface Table.

Example: 'MyCustomInternalInterface'

interface_type — Interface direction

'IN' (default) | 'OUT'

Interface direction relative to the generated IP core, specified as a character vector.

For example, if the interface is an input to the generated IP core, set interface_type to 'IN'.

port_name — Port name

' ' (default) | character vector

Name of generated IP core port in the HDL code, specified as a character vector.

Example: 'MyIPCoreInternalIOInterfacePort'

port_width — Port bit width

8 (default) | integer

Bit width of generated IP core port, specified as an integer.

interface_connection — Internal IO interface connection

' ' (default) | character vector

Internal IO interface port to connect with generated IP core port, specified as a character vector. The internal IO interface port is an existing port in the reference design. Its port bit width must match `port_width`.

Different synthesis tools have different formats for the internal IO interface port.

Synthesis Tool	Format Example
Altera Quartus II	'internal_ip_0.In0'
Xilinx Vivado	'internal_ip_0/In0'
Xilinx ISE	'internal_In0'

Example: 'internal_ip_0.In0'

Example: 'internal_ip_0/In0'

Example: 'internal_In0'

See Also

`hdlcoder.ReferenceDesign`

Topics

“Define Custom Board and Reference Design for Zynq Workflow”

“Define Custom Board and Reference Design for Intel SoC Workflow”

“Register a Custom Board”

“Register a Custom Reference Design”

“Board and Reference Design Registration System”

Introduced in R2015b

addClockInterface

Class: hdlcoder.ReferenceDesign

Package: hdlcoder

Add clock and reset interface

Syntax

```
addClockInterface('ClockConnection',clock_port,'ResetConnection',reset_port)
addClockInterface('ClockConnection',clock_port,'ResetConnection',reset_port,
Name,Value)
```

Description

addClockInterface('ClockConnection',clock_port,'ResetConnection',reset_port) adds a clock and reset interface to an hdlcoder.ReferenceDesign object.

addClockInterface('ClockConnection',clock_port,'ResetConnection',reset_port, Name,Value) adds a clock and reset interface to the hdlcoder.ReferenceDesign object with additional options specified by one or more Name,Value pair arguments. When you specify these arguments, in the HDL Workflow Advisor, HDL Coder adds a **Set Target Frequency** task. To modify the output clock frequency setting in the reference design clock wizard, in this task, specify the **Target Frequency (MHz)**.

Input Arguments

clock_port — Clock port name

' ' (default) | character vector

Reference design port that is connected to the IP core clock port, specified as a character vector.

Example: 'processing_system7_1/FCLK_CLK0'

reset_port — Reset port name

' ' (default) | character vector

Reference design port that is connected to the IP core reset port, specified as a character vector.

Example: 'proc_sys_reset/peripheral_aresetn'

Name-Value Pair Arguments

Specify optional comma-separated pairs of Name,Value arguments. Name is the argument name and Value is the corresponding value. Name must appear inside quotes. You can specify several name and value pair arguments in any order as Name1,Value1,...,NameN,ValueN.

DefaultFrequencyMHz — The default frequency in MHz

0 (default) | integer

The default clock frequency in MHz of the clock module IP in the reference design, specified as an integer. When you open the HDL Workflow Advisor, HDL Coder populates this information for **Default (MHz)** in the **Set Target Frequency** task.

Example: 'DefaultFrequencyMHz', 50 specifies the default frequency as 50 MHz.

MinFrequencyMHz — The minimum frequency in MHz

0 (default) | integer

The minimum clock frequency in MHz of the clock module IP in the reference design, specified as an integer.

Example: 'MinFrequencyMHz', 5 specifies the minimum clock frequency as 5 MHz.

MaxFrequencyMHz — The maximum frequency in MHz

0 (default) | integer

The maximum clock frequency in MHz of the clock module IP in the reference design, specified as an integer. In the HDL Workflow Advisor, HDL Coder sets the **Frequency Range (MHz)** in the **Set Target Frequency** task based on the MinFrequencyMHz and MaxFrequencyMHz values that you specify.

Example: 'MaxFrequencyMHz', 500 specifies the maximum clock frequency as 500 MHz.

ClockNumber — Clock output port number

1 (default) | integer

Port number of the clock output from the clock module IP in the reference design, specified as an integer.

Example: 'ClockNumber', 2 specifies to use the second output port in the clock module IP as the clock port.

ClockModuleInstance — Clock module name

'clk_wiz_0' (default) | character vector

The name of the clock module IP in the reference design, specified as a character vector.

Example: 'ClockModuleInstance', 'clk_wiz_1' specifies clk_wiz_1 as the name of the clock module IP.

See Also

addAXI4SlaveInterface | hdlcoder.ReferenceDesign

Topics

“Define Custom Board and Reference Design for Zynq Workflow”

“Define Custom Board and Reference Design for Intel SoC Workflow”

“Register a Custom Board”

“Register a Custom Reference Design”

“Define Custom Parameters and Callback Functions for Custom Reference Design”

“Board and Reference Design Registration System”

Introduced in R2015a

addCustomEDKDesign

Class: hdlcoder.ReferenceDesign

Package: hdlcoder

Specify Xilinx EDK MHS project file

Syntax

```
addCustomEDKDesign('CustomEDKMHS',mhs_project_file)
```

Description

`addCustomEDKDesign('CustomEDKMHS',mhs_project_file)` specifies the MHS project file that contains the Xilinx EDK embedded system design. Use this method if your synthesis tool is Xilinx ISE.

Input Arguments

mhs_project_file — MHS project file

character vector

MHS project file for Xilinx EDK embedded system design, specified as a character vector.

Example: 'system.mhs'

Tips

- If your synthesis tool is Xilinx Vivado, use the `addCustomVivadoDesign` method.
- If your synthesis tool is Altera Quartus II, use the `addCustomQsysDesign` method.

See Also

`addCustomQsysDesign` | `addCustomVivadoDesign` | `hdlcoder.ReferenceDesign`

Topics

“Define Custom Board and Reference Design for Zynq Workflow”

“Define Custom Board and Reference Design for Intel SoC Workflow”

“Register a Custom Board”

“Register a Custom Reference Design”

“Board and Reference Design Registration System”

Introduced in R2015a

addCustomQsysDesign

Class: hdlcoder.ReferenceDesign

Package: hdlcoder

Specify Altera Qsys project file

Syntax

```
addCustomQsysDesign('CustomQsysPrjFile',qsys_project_file)
```

Description

`addCustomQsysDesign('CustomQsysPrjFile',qsys_project_file)` specifies the Qsys project file that contains the Altera Qsys embedded system design. Use this method if your synthesis tool is Altera Quartus II.

Input Arguments

qsys_project_file — Qsys project file

character vector

Qsys project file for Altera Qsys embedded system design, specified as a character vector.

Example: 'system_soc.qsys'

Tips

- If you have more than one AXI Master IP, in the custom qsys project file, you must make sure that the AXI Master IPs connect to the same AXI Interconnect IP. The AXI4 slave interfaces in the HDL IP core also connect to this Interconnect.
- If your synthesis tool is Xilinx Vivado, use the `addCustomVivadoDesign` method.
- If your synthesis tool is Xilinx ISE, use the `addCustomEDKDesign` method.

See Also

`addCustomEDKDesign` | `addCustomVivadoDesign` | `hdlcoder.ReferenceDesign`

Topics

“Define Custom Board and Reference Design for Intel SoC Workflow”

“Register a Custom Board”

“Register a Custom Reference Design”

“Board and Reference Design Registration System”

Introduced in R2015a

addCustomVivadoDesign

Class: hdlcoder.ReferenceDesign

Package: hdlcoder

Specify Xilinx Vivado exported block design Tcl file

Syntax

```
addCustomVivadoDesign('CustomBlockDesignTcl',bd_tcl_file)
```

Description

`addCustomVivadoDesign('CustomBlockDesignTcl',bd_tcl_file)` specifies the exported block design Tcl file that contains the Xilinx Vivado embedded system design. Use this method if your synthesis tool is Xilinx Vivado.

Input Arguments

bd_tcl_file — Block design Tcl file

character vector

Block design Tcl file that you exported from your Xilinx Vivado embedded system design project, specified as a character vector. The Tcl file name must be the same as the Vivado block diagram name.

Example: 'system_top.tcl'

Tips

- If you have more than one AXI Master IP, in the custom block design Tcl file, you must make sure that the AXI Master IPs connect to the same AXI Interconnect IP. The AXI4 slave interfaces in the HDL IP core also connect to this Interconnect.
- If your synthesis tool is Xilinx ISE, use the `addCustomEDKDesign` method.
- If your synthesis tool is Altera Quartus II, use the `addCustomQsysDesign` method.

See Also

`addCustomEDKDesign` | `addCustomQsysDesign` | `hdlcoder.ReferenceDesign`

Topics

“Define Custom Board and Reference Design for Zynq Workflow”

“Register a Custom Board”

“Register a Custom Reference Design”

“Board and Reference Design Registration System”

Introduced in R2015a

addIPRepository

Class: hdlcoder.ReferenceDesign

Package: hdlcoder

Include IP modules from your IP repository folder in your custom reference design

Syntax

```
addIPRepository('IPListFunction',IP_list_function)
addIPRepository('IPListFunction',IP_list_function,Name,Value)
```

Description

`addIPRepository('IPListFunction',IP_list_function)` adds IP modules that are in the IP repository folder to your reference design project.

`addIPRepository('IPListFunction',IP_list_function,Name,Value)` adds IP modules that are in the IP repository folder to your reference design project with additional options specified by one or more `Name,Value` pair arguments.

Before you use this method, define the IP list function that points to the IP modules in the repository folder. To learn more, see “Define and Add IP Repository to Custom Reference Design”.

Input Arguments

IP_list_function — Name and path to the function that points to the IP repository

'' (default) | character vector

Name and path to the function that points to IP modules in the IP repository folder to add to the reference design project, specified as a character vector.

Example: 'adi.hdmi.vivado.hdlcoder_video_iplist'

Example: 'mathworks.hdlcoder.vivado.hdlcoder_video_iplist'

Name-Value Pair Arguments

Specify optional comma-separated pairs of `Name,Value` arguments. `Name` is the argument name and `Value` is the corresponding value. `Name` must appear inside quotes. You can specify several name and value pair arguments in any order as `Name1,Value1,...,NameN,ValueN`.

NotExistMessage — Error message to display if IP function is not found

'' (default) | character vector

Error message that you create to be displayed if IP list function is not found on the MATLAB path, specified as a character vector.

Example: 'IP repository cannot be found'

See Also

hdlcoder.Board | hdlcoder.ReferenceDesign

Topics

- "Define Custom Board and Reference Design for Zynq Workflow"
- "Define Custom Board and Reference Design for Intel SoC Workflow"
- "Define and Add IP Repository to Custom Reference Design"
- "Board and Reference Design Registration System"
- "Register a Custom Board"
- "Register a Custom Reference Design"

Introduced in R2017a

addParameter

Class: hdlcoder.ReferenceDesign

Package: hdlcoder

Add and define custom parameters for your reference design

Syntax

```
addParameter('ParameterID',parameter_name,'DisplayName',  
display_name,'DefaultValue',default_value)  
addParameter('ParameterID',parameter_name,'DisplayName',  
display_name,'DefaultValue',default_value,Name,Value)
```

Description

`addParameter('ParameterID',parameter_name,'DisplayName',display_name,'DefaultValue',default_value)` adds and defines a custom parameter for your reference design with a text box that displays the default value of the parameter.

`addParameter('ParameterID',parameter_name,'DisplayName',display_name,'DefaultValue',default_value,Name,Value)` adds and defines a custom parameter for your reference design with additional options specified by one or more `Name, Value` pair arguments.

The custom parameters are optional. In the HDL Workflow Advisor **Set Target Reference Design** task, HDL Coder populates the Reference design parameters section with the custom parameters and the options that you specify.

Input Arguments

parameter_name — Custom parameter name

' ' (default) | character vector

Custom parameter name, specified as a character vector.

Example: 'DUTPath'

Example: 'ChannelMapping'

display_name — Custom parameter display name

' ' (default) | character vector

Name that you want to display for the custom parameter in the HDL Workflow Advisor, specified as a character vector. This name appears in the **Reference design parameters** section in the **Set Target Reference Design** task.

Example: 'DUT Path'

Example: 'Channel Mapping'

default_value — Custom parameter default value

' ' (default) | character vector

Default value to set for the custom parameter, specified as a character vector. In the **Set Target Reference Design** task in the HDL Workflow Advisor, HDL Coder displays the default value of the custom parameter inside a text box.

Example: '1'

Name-Value Pair Arguments

Specify optional comma-separated pairs of `Name`, `Value` arguments. `Name` is the argument name and `Value` is the corresponding value. `Name` must appear inside quotes. You can specify several name and value pair arguments in any order as `Name1, Value1, . . . , NameN, ValueN`.

ParameterType — Parameter widget

`hdlcoder.ParameterType.Edit` (default) | `hdlcoder.ParameterType.DropDown` | `hdlcoder.ParameterType.Edit`

Specify the widget type to use for the parameter values. By default, the `ParameterType` is a text box. If you specify the drop-down list for `ParameterType`, use the `Choice` property to list the parameter values as a cell array of character vectors.

Example: `'ParameterType',hdlcoder.ParameterType.DropDown` specifies a drop-down list with the values that the parameter can take.

Choice — Choice of parameter values

`''` (default) | cell array of character vectors

The list of choices that you can specify for the custom parameter, specified as a cell array of character vectors. To specify this list, set `ParameterType` to `hdlcoder.ParameterType.DropDown`.

Example: `'ParameterType',hdlcoder.ParameterType.DropDown,'Choice',{'Rx','Tx'}` specifies a drop-down list with Rx and Tx as the drop-down values.

See Also

`hdlcoder.ReferenceDesign`

Topics

“Define Custom Board and Reference Design for Zynq Workflow”

“Define Custom Board and Reference Design for Intel SoC Workflow”

“Register a Custom Board”

“Register a Custom Reference Design”

“Define Custom Parameters and Callback Functions for Custom Reference Design”

“Board and Reference Design Registration System”

Introduced in R2016b

CallbackCustomProgrammingMethod

Class: hdlcoder.ReferenceDesign

Package: hdlcoder

Function handle for custom callback function that gets executed during Program Target Device task in the Workflow Advisor

Syntax

CallbackCustomProgrammingMethod

Description

CallbackCustomProgrammingMethod registers a function handle for the callback function that gets executed when running the **Program Target Device** task in the HDL Workflow Advisor. If hRD is the reference design object that you construct with the hdlcoder.ReferenceDesign class, then use this syntax to register the function handle:

```
hRD.CallbackCustomProgrammingMethod = @my_reference_design.callback_CustomProgrammingMethod;
```

To define your callback function, create a file that defines a MATLAB function and add it to your MATLAB path. You can use any name for the callback function. In this example, the function name is callback_PostBuildBitstream, located in the reference design package folder, +my_reference_design.

With this callback function, you can specify a custom programming method to program the target device. This example code shows how to create the callback function.

```
function [status, log] = callback_CustomProgrammingMethod(infoStruct)
% Reference design callback function for custom programming method
%
% infoStruct: information in structure format
% infoStruct.ReferenceDesignObject: current reference design registration object
% infoStruct.BoardObject: current board registration object
% infoStruct.ParameterStruct: custom parameters of the current reference design, in struct format
% infoStruct.HDLModelDutPath: the block path to the HDL DUT subsystem
% infoStruct.BitstreamPath: the path to the generated FPGA bitstream file
% infoStruct.ToolProjectFolder: the path to synthesis tool project folder
% infoStruct.ToolProjectName: the synthesis tool project name
% infoStruct.ToolCommandString: the command for running a tcl file
%
% status: process run status
%       status == true means process run successfully
%       status == false means process run failed
% log:    output log string
status = true;
log = sprintf('Run custom programming method callback...\n');

% Enter your commands for custom programming here
% ...
% ...
```

end

In the HDL Workflow Advisor, HDL Coder selects the custom programming method to program the target SoC device. If you do not specify the custom programming method, HDL Coder provides JTAG and Download as the options to program the target device.

When you create the callback function, pass the `infoStruct` argument to the function. The argument contains the reference design and board information in a `structure` format. Use this information to specify custom settings for the build process and bitstream generation.

See Also

`hdlcoder.ReferenceDesign`

Topics

“Define Custom Board and Reference Design for Zynq Workflow”

“Define Custom Board and Reference Design for Intel SoC Workflow”

“Register a Custom Board”

“Register a Custom Reference Design”

“Define Custom Parameters and Callback Functions for Custom Reference Design”

“Board and Reference Design Registration System”

Introduced in R2016a

CustomizeReferenceDesignFcn

Class: hdlcoder.ReferenceDesign

Package: hdlcoder

Function handle for callback function that gets executed before Set Target Interface task in the HDL Workflow Advisor

Syntax

CustomizeReferenceDesignFcn

Description

CustomizeReferenceDesignFcn registers a function handle for the callback function that gets executed before **Set Target Interface** task in the HDL Workflow Advisor. By using this callback function, you can customize the block design Tcl file, reference design interfaces, reference design interface properties, and IP repositories in your reference design.

Tip Before you use the callback function, in the `plugin_rd.m` file, you must define a reference design parameter by using the `addParameter` method of the `hdlcoder.ReferenceDesign` class.

If `hRD` is the reference design object that you construct with the `hdlcoder.ReferenceDesign` class, then use this syntax to register the function handle.

```
hRD.CustomizeReferenceDesignFcn = @my_reference_design.customcallback_aximaster;
```

To define your callback function, create a file that defines a MATLAB function and add it to your MATLAB path. You can use any name for the callback function. In this example, the function name is `customcallback_aximaster`, and is located in the reference design package folder `+my_reference_design`.

For example, you can specify whether you want an AXI4 Master or AXI4 only reference design. In the `plugin_rd.m` file, use the `addParameter` method to specify the different parameter choices as a dropdown.

```
% ...
% Parameter For calling AXI4 master interface from Callback function
hdlcoder.addParameter('ParameterID',    'interface_name', ...
                    'DisplayName',     'Reference_design_interface_name', ...
                    'DefaultValue',    'AXI4 Master',...
                    'ParameterType',   hdlcoder.ParameterType.Dropdown, ...
                    'Choice',          {'AXI4 Master','AXI4 Only'});
hRD.CustomizeReferenceDesignFcn = @my_reference_design.customcallback_aximaster;
% ...
```

In the callback function, you can dynamically change the reference design interfaces depending on the interface types. When you create the callback function, pass the `infoStruct` argument to the function. The argument contains the reference design and board information in a `structure` format.

```

% Callback function to control AXI Master and AXI4 interface information dynamically

function customcallback_aximaster(infoStruct)
%% Reference design callback run at the end of the task Set Target Reference Design
%
% infoStruct: information in structure format
% infoStruct.ReferenceDesignObject: current reference design registration object
% infoStruct.BoardObject: current board registration object
% infoStruct.ParameterStruct: custom parameters of the current reference design, in struct format
% infoStruct.HDLModelDutPath: the block path to the HDL DUT subsystem
% infoStruct.ReferenceDesignToolVersion: Reference design Tool Version set in 1.2 Task

hRD = infoStruct.ReferenceDesignObject;
paramStruct = infoStruct.ParameterStruct;
interface_name = paramStruct.interface_name;

if strcmp(interface_name, 'AXI4 Only')
    hRD.addAXI4SlaveInterface( ...
        'InterfaceConnection', 'axi_interconnect_2/M01_AXI', ...
        'BaseAddress', '0x00000000', ...
        'MasterAddressSpace', 'hdlverifier_axi_master_0/axi4m', ...
        'InterfaceType', 'AXI4');

% To validate IP repository and AXI4 master interface signals
elseif strcmp(interface_name, 'AXI4 Master')
    hRD.addAXI4SlaveInterface( ...
        'InterfaceConnection', 'axi_interconnect_2/M01_AXI', ...
        'BaseAddress', '0x00000000', ...
        'MasterAddressSpace', 'hdlverifier_axi_master_0/axi4m', ...
        'InterfaceType', 'AXI4');

    hRD.addAXI4MasterInterface(...
        'InterfaceID', 'AXI4 Master', ...
        'ReadSupport', true, ...
        'WriteSupport', true, ...
        'MaxDataWidth', 128, ...
        'AddrWidth', 32, ...
        'DefaultReadBaseAddr', hex2dec('40000000'), ...
        'DefaultWriteBaseAddr', hex2dec('41000000'), ...
        'InterfaceConnection', 'axi_interconnect_1/S01_AXI', ...
        'TargetAddressSegments', {{'mig_7series_0/memmap/memaddr', hex2dec('40000000'), hex2dec('40000000')}}})

end
end

```

In the HDL Workflow Advisor, on the **Set Target Reference Design** task, when you select the custom reference design that you want to customize for the target board, HDL Coder populates the reference design parameters. Depending on the parameter choices such as the interface types you specify, the callback function is evaluated. After you run this task, when you select the **Set Target Interface** task, the target interfaces get populated in the Target platform interface table.

See Also

hdlcoder.ReferenceDesign

Topics

“Define Custom Board and Reference Design for Zynq Workflow”
 “Define Custom Board and Reference Design for Intel SoC Workflow”
 “Register a Custom Reference Design”
 “Define Custom Parameters and Callback Functions for Custom Reference Design”
 “Customize Reference Design Dynamically Based on Reference Design Parameters”
 “Board and Reference Design Registration System”

Introduced in R2020a

EmbeddedCoderSupportPackage

Class: hdlcoder.ReferenceDesign

Package: hdlcoder

Specify whether to use an Embedded Coder support package

Syntax

EmbeddedCoderSupportPackage

Description

EmbeddedCoderSupportPackage specifies if you want to use an Embedded Coder support package for your reference design. Use this parameter if you are targeting a standalone FPGA board or an SoC device such as the Xilinx Zynq®-7000 platform.

If you are targeting a standalone FPGA board, the reference designs do not require an Embedded Coder support package. If hRD is the reference design object that you construct with the hdlcoder.ReferenceDesign class, then use this syntax:

```
hRD.EmbeddedCoderSupportPackage = hdlcoder.EmbeddedCoderSupportPackage.None;
```

When you are not using the support package, HDL Coder does not have the **Generate Software Interface Model** task in the HDL Workflow Advisor.

If you are targeting SoC devices, use this syntax depending on whether you are using an Altera SoC or a Xilinx Zynq platform.

```
hRD.EmbeddedCoderSupportPackage = hdlcoder.EmbeddedCoderSupportPackage.Zynq;
hRD.EmbeddedCoderSupportPackage = hdlcoder.EmbeddedCoderSupportPackage.AlterasoC;
```

See Also

hdlcoder.ReferenceDesign

Topics

""

"IP Core Generation Workflow for Standalone FPGA Devices"

"Register a Custom Board"

"Register a Custom Reference Design"

"Board and Reference Design Registration System"

Introduced in R2016b

PostBuildBitstreamFcn

Class: hdlcoder.ReferenceDesign

Package: hdlcoder

Function handle for callback function that gets executed after Build FPGA Bitstream task in the HDL Workflow Advisor

Syntax

PostBuildBitstreamFcn

Description

PostBuildBitstreamFcn registers a function handle for the callback function that gets called at the end of the **Build FPGA Bitstream** task in the HDL Workflow Advisor. If hRD is the reference design object that you construct with the hdlcoder.ReferenceDesign class, then use this syntax to register the function handle:

```
hRD.PostBuildBitstreamFcn = @my_reference_design.callback_PostBuildBitstream;
```

To define your callback function, create a file that defines a MATLAB function and add it to your MATLAB path. You can use any name for the callback function. In this example, the function name is callback_PostBuildBitstream, located in the reference design package folder +my_reference_design.

With this callback function, you can specify custom settings when HDL Coder runs the build process and generates the bitstream. This example code shows how to create the callback function. The function displays the status after running the task, and the board and reference design information.

```
function [status, log] = callback_PostBuildBitstream(infoStruct)
% Reference design callback run at the end of the task Build FPGA Bitstream
%
% infoStruct: information in structure format
% infoStruct.ReferenceDesignObject: current reference design registration object
% infoStruct.BoardObject: current board registration object
% infoStruct.ParameterStruct: custom parameters of the current reference design, in struct format
% infoStruct.HDLModelDutPath: the block path to the HDL DUT subsystem
% infoStruct.BitstreamPath: the path to generated FPGA bitstream file
%
% status: process run status
%         status == true means process run successfully
%         status == false means process run failed
% log:    output log string

status = false;
log = sprintf('Run post build bitstream callback\n%s\n%s\n', infoStruct.HDLModelDutPath, infoStru

% Exporting the InfoStruct Contents
% ...
% ...

end
```

When you create the callback function, pass the `infoStruct` argument to the function. The argument contains the reference design and board information in a `structure` format. Use this information to specify custom settings for the build process and bitstream generation.

See Also

`hdlcoder.ReferenceDesign`

Topics

“Define Custom Board and Reference Design for Zynq Workflow”

“Define Custom Board and Reference Design for Intel SoC Workflow”

“Register a Custom Board”

“Register a Custom Reference Design”

“Define Custom Parameters and Callback Functions for Custom Reference Design”

“Board and Reference Design Registration System”

Introduced in R2016b

PostCreateProjectFcn

Class: hdlcoder.ReferenceDesign

Package: hdlcoder

Function handle for callback function that gets executed after Create Project task in the HDL Workflow Advisor

Syntax

PostCreateProjectFcn

Description

PostCreateProjectFcn registers a function handle for the callback function that gets called at the end of the **Create Project** task in the HDL Workflow Advisor. If hRD is the reference design object that you construct with the hdlcoder.ReferenceDesign class, then use this syntax to register the function handle.

```
hRD.PostCreateProjectFcn = @my_reference_design.callback_PostCreateProject;
```

To define your callback function, create a file that defines a MATLAB function and add it to your MATLAB path. You can use any name for the callback function. In this example, the function name is callback_PostCreateProject, and is located in the reference design package folder +my_reference_design.

With this callback function, you can specify custom settings for reference design project creation. This example code shows how to create the callback function. The function exports the contents of the board and reference design object to a PostCreateProjectInfo.txt file, and validates that the project creation task ran successfully.

```
function [status, log] = callback_PostCreateProject(infoStruct)
% Reference design callback run at the end of the task Create Project
%
% infoStruct: information in structure format
% infoStruct.ReferenceDesignObject: current reference design registration object
% infoStruct.BoardObject: current board registration object
% infoStruct.ParameterStruct: custom parameters of the current reference design, in struct format
% infoStruct.HDLModelDutPath: the block path to the HDL DUT subsystem
% infoStruct.ToolProjectFolder: the path to synthesis tool project folder
% infoStruct.ToolProjectName: the synthesis tool project name
%
% status: process run status
%       status == true means process run successfully
%       status == false means process run failed
% log:   output log string

status = false;
log = sprintf('Run post create project callback\n%s', evalc('infoStruct'));

% Exporting the InfoStruct Contents
% ...
% ...
```

end

In the HDL Workflow Advisor, when HDL Coder runs the **Create Project** task, it executes the callback function at the end of the task.

When you create the callback function, pass the `infoStruct` argument to the function. The argument contains the reference design and board information in a `structure` format. Use this information to specify custom settings for the reference design project creation.

See Also

`hdlcoder.ReferenceDesign`

Topics

“Define Custom Board and Reference Design for Zynq Workflow”

“Define Custom Board and Reference Design for Intel SoC Workflow”

“Register a Custom Board”

“Register a Custom Reference Design”

“Define Custom Parameters and Callback Functions for Custom Reference Design”

“Board and Reference Design Registration System”

Introduced in R2016b

PostSWInterfaceFcn

Class: hdlcoder.ReferenceDesign

Package: hdlcoder

Function handle for custom callback function that gets executed after Generate Software Interface Model task in the HDL Workflow Advisor

Syntax

PostSWInterfaceFcn

Description

PostSWInterfaceFcn registers a function handle for the callback function that gets executed at the end of the **Generate Software Interface Model** task in the HDL Workflow Advisor. If hRD is the reference design object that you construct with the hdlcoder.ReferenceDesign class, use this syntax to register the function handle.

```
hRD.PostSWInterfaceFcn = @my_reference_design.callback_PostSWInterface;
```

To define your callback function, create a file that defines a MATLAB function and add it to your MATLAB path. You can use any name for the callback function. In this example, the function name is callback_PostSWInterface, and is located in the reference design package folder +my_reference_design.

With this callback function, you can change the generated software interface model for the custom reference design.

This example code shows how to create the callback function. The function adds a DocBlock in the software interface model.

```
function [status, log] = callback_PostSWInterface(infoStruct)
% Reference design callback run at the end of the task
% Generate Software Interface Model
%
% infoStruct: information in structure format
% infoStruct.ReferenceDesignObject: current reference design registration object
% infoStruct.BoardObject: current board registration object
% infoStruct.ParameterStruct: custom parameters of the current reference design, in struct format
% infoStruct.HDLModelDutPath: the block path to the HDL DUT subsystem
% infoStruct.SWModelDutPath: the block path to the SW interface subsystem
%
% feature controlled by IPCoreSoftwareInterfaceLibrary
% infoStruct.SWLibBlockPath: the block path to the SW interface library block
% infoStruct.SWLibFolderPath: the folder path to the SW interface library
%
% status: process run status
%         status == true means process run successfully
%         status == false means process run failed
% log:    output log string
```

```
status = true;
log = '';
swDutPath = infoStruct.SWModelDutPath;
add_block(['simulink/Model-Wide', char(10), 'Utilities/DocBlock'], sprintf('%s/DocBlock', swDutPath));
end
```

In the HDL Workflow Advisor, when HDL Coder runs the **Generate Software Interface Model** task, it executes the callback function at the end of the task.

When you create the callback function, pass the `infoStruct` argument to the function. The argument contains the reference design and board information in a `structure` format. Use this information to specify custom settings for software interface model generation.

See Also

`hdlcoder.ReferenceDesign`

Topics

“Define Custom Board and Reference Design for Zynq Workflow”

“Define Custom Board and Reference Design for Intel SoC Workflow”

“Register a Custom Board”

“Register a Custom Reference Design”

“Define Custom Parameters and Callback Functions for Custom Reference Design”

“Board and Reference Design Registration System”

Introduced in R2016b

PostTargetInterfaceFcn

Class: hdlcoder.ReferenceDesign

Package: hdlcoder

Function handle for callback function that gets executed after Set Target Interface task in the HDL Workflow Advisor

Syntax

PostTargetInterfaceFcn

Description

PostTargetInterfaceFcn registers a function handle for the callback function that gets called at the end of the **Set Target Interface** task in the HDL Workflow Advisor. If hRD is the reference design object that you construct with the hdlcoder.ReferenceDesign class, then use this syntax to register the function handle.

```
hRD.PostTargetInterfaceFcn = @my_reference_design.callback_PostTargetInterface;
```

To define your callback function, create a file that defines a MATLAB function and add it to your MATLAB path. You can use any name for the callback function. In this example, the function name is callback_PostTargetInterface, and is located in the reference design package folder +my_reference_design.

With this callback function, you can enable custom validations. This example code shows how to create the callback function. If the custom parameter DUTPath is set to Rx, the function validates that the reference design does not support the LEDs General Purpose [0:7] interface.

```
function callback_PostTargetInterface(infoStruct)
% Reference design callback run at the end of the task Set Target Interface
%
% infoStruct: information in structure format
% infoStruct.ReferenceDesignObject: current reference design registration object
% infoStruct.BoardObject: current board registration object
% infoStruct.ParameterStruct: custom parameters of the current reference design, in struct format
% infoStruct.HDLModelDutPath: the block path to the HDL DUT subsystem
% infoStruct.ProcessorFPGASynchronization: Processor/FPGA synchronization mode
% infoStruct.InterfaceStructCell: target interface table information
%                               a cell array of structure, for example:
%                               infoStruct.InterfaceStructCell{1}.PortName
%                               infoStruct.InterfaceStructCell{1}.PortType
%                               infoStruct.InterfaceStructCell{1}.DataType
%                               infoStruct.InterfaceStructCell{1}.IOInterface
%                               infoStruct.InterfaceStructCell{1}.IOInterfaceMapping

hRD = infoStruct.ReferenceDesignObject;
refDesignName = hRD.ReferenceDesignName;

% validate that when specific parameter is set to specific value, reference
% design does not support specific interface
```



```
paramStruct = infoStruct.ParameterStruct;
interfaceStructCell = infoStruct.InterfaceStructCell;
for ii = 1:length(interfaceStructCell)
    interfaceStruct = interfaceStructCell{ii};
    if strcmp(paramStruct.DutPath, 'Rx') && ...
        strcmp(interfaceStruct.IOInterface, 'LEDs General Purpose [0:7]')
        error('LEDs General Purpose [0:7] must not be used when the DUT path is Rx');
    end
end
end
end
```

In the HDL Workflow Advisor, when HDL Coder runs the **Set Target Interface** task, it executes the callback function at the end of the task. If you specify Rx as the **DUT Path** and use the LEDs General Purpose [0:7] interface for your DUT port, the coder generates an error.

When you create the callback function, pass the `infoStruct` argument to the function. The argument contains the reference design and board information in a structure format. Use this information to enable custom validations on the DUT in your Simulink model.

See Also

`hdlcoder.ReferenceDesign`

Topics

“Define Custom Board and Reference Design for Zynq Workflow”

“Define Custom Board and Reference Design for Intel SoC Workflow”

“Register a Custom Board”

“Register a Custom Reference Design”

“Define Custom Parameters and Callback Functions for Custom Reference Design”

“Board and Reference Design Registration System”

Introduced in R2016b

PostTargetReferenceDesignFcn

Class: `hdlcoder.ReferenceDesign`

Package: `hdlcoder`

Function handle for callback function that gets executed after Set Target Reference Design task in the HDL Workflow Advisor

Syntax

`PostTargetReferenceDesignFcn`

Description

`PostTargetReferenceDesignFcn` registers a function handle for the callback function that gets called at the end of the **Set Target Reference Design** task in the HDL Workflow Advisor. If `hRD` is the reference design object that you construct with the `hdlcoder.ReferenceDesign` class, use this syntax to register the function handle:

```
hRD.PostTargetReferenceDesignFcn = @my_reference_design.callback_PostTargetReferenceDesign
```

To define your callback function, create a file that defines a MATLAB function and add it to your MATLAB path. You can use any name for the callback function. In this example, the function name is `callback_PostTargetReferenceDesign`, and is located in the reference design package folder `+my_reference_design`.

With the callback function, you can enable custom validations for your design. This example code shows how to create the callback function and validate that the reset type is synchronous.

```
function callback_PostTargetReferenceDesign(infoStruct)
% Reference design callback run at the end of the task Set Target Reference Design
%
% infoStruct: information in structure format
% infoStruct.ReferenceDesignObject: current reference design registration object
% infoStruct.BoardObject: current board registration object
% infoStruct.ParameterStruct: custom parameters of the current reference design, in struct format
% infoStruct.HDLModelDutPath: the block path to the HDL DUT subsystem
mdlName = bdroot(infoStruct.HDLModelDutPath);
hRD = infoStruct.ReferenceDesignObject;
refDesignName = hRD.ReferenceDesignName;

isResetSync = strcmpi(hdlget_param(mdlName, 'ResetType'), 'Synchronous');

% Reset must be synchronous
if ~isResetSync
    error('Invalid Reset type. Reset type must be synchronous');
end
end
```

In the HDL Workflow Advisor, when HDL Coder runs the **Set Target Reference Design** task, it executes the callback function. If the reset type is not synchronous, the coder generates an error.

When you create the callback function, pass the `infoStruct` argument to the function. The argument contains the reference design and board information in a `structure` format. Use this information to enable custom validations on the DUT in your Simulink model.

See Also

`hdlcoder.ReferenceDesign`

Topics

“Define Custom Board and Reference Design for Zynq Workflow”

“Define Custom Board and Reference Design for Intel SoC Workflow”

“Register a Custom Board”

“Register a Custom Reference Design”

“Define Custom Parameters and Callback Functions for Custom Reference Design”

“Board and Reference Design Registration System”

Introduced in R2016b

validateReferenceDesign

Class: hdlcoder.ReferenceDesign

Package: hdlcoder

Check property values in reference design object

Syntax

```
validateReferenceDesign
```

Description

`validateReferenceDesign` checks that the `hdlcoder.ReferenceDesign` object has nondefault values for all required properties, and that property values have valid data types. This method does not check the correctness of property values for the target board. If validation fails, the software displays an error message.

See Also

`hdlcoder.ReferenceDesign`

Topics

“Define Custom Board and Reference Design for Zynq Workflow”

“Define Custom Board and Reference Design for Intel SoC Workflow”

“Register a Custom Board”

“Register a Custom Reference Design”

“Board and Reference Design Registration System”

Introduced in R2015a